



# 車架零件

# Frames & Frame Parts



**MAGURA**  
125 YEARS  
PERFORMANCE  
COMPONENTS

1893



 瑪古拉亞洲 MAGURA ASIA 

<http://www.magura.com.tw>



**MAGURA**

## FRAME COMPONENTS

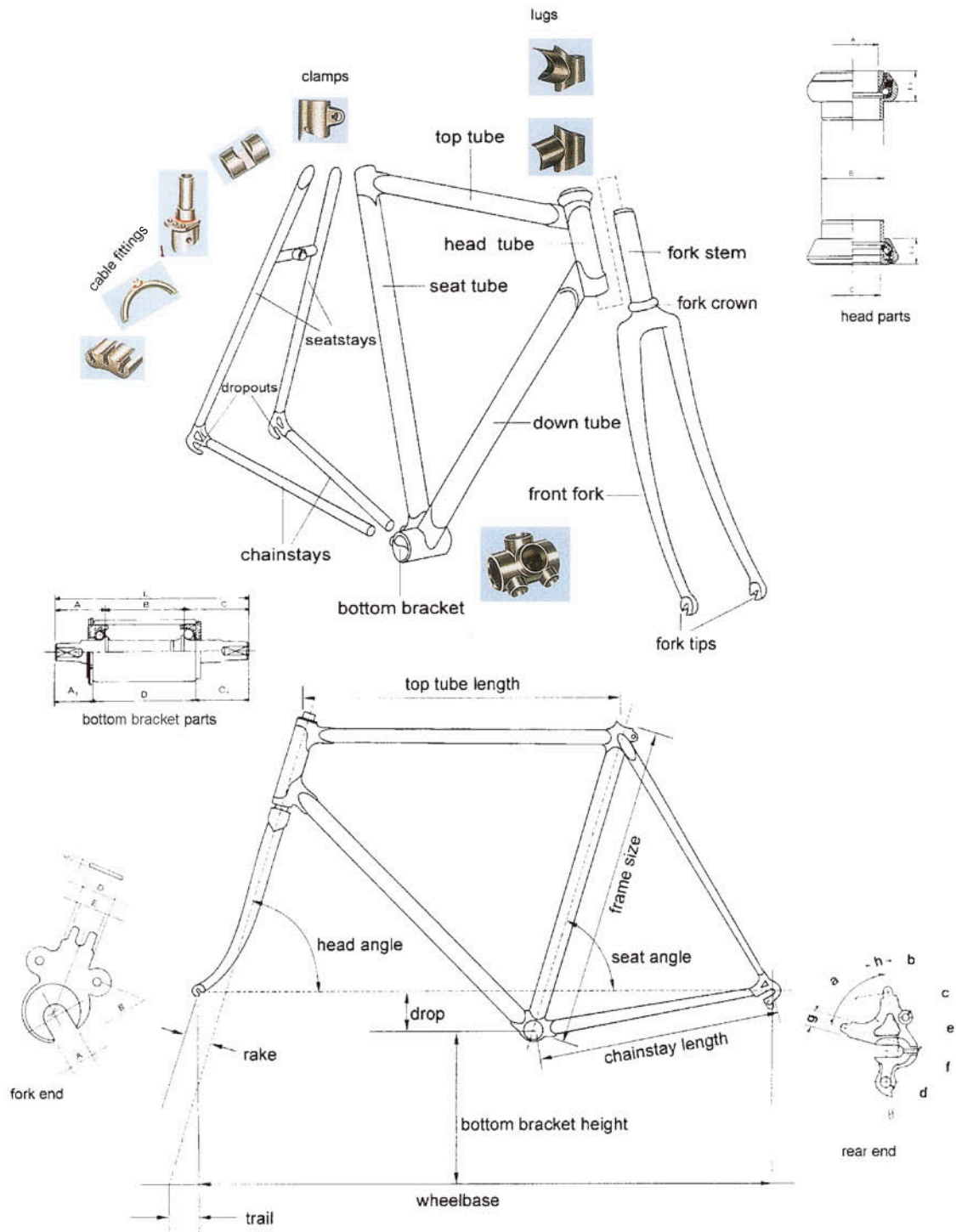

# FRAME & FRAME PARTS ADVERTISERS

## B01 Frames

Adk Technology Limited 環捷	154-156
Agogo Bike Co., Ltd. 鉅讚	157
Alu. Mega Industrial Co., Ltd. 鋁大	158
A-Pro Tech Co., Ltd. 野寶	153
Arkietech Engineering Co., Ltd. 安吉特	160
Aster Bikes Technology Co., Ltd. 亞仕大	161
Bev Int'l Corp. 精創	164
Bixetec International Co., Ltd. 巧創	162-163
Carbotec Industrial Co., Ltd. 榮信	165
Caribou Enterprise Co., Ltd. 坤泉	166
Chang Huei Enterprise Co., Ltd. 昌徽	167
Cycle Lucha Co., Ltd. 綸昶	228
Forever Machine Ind. Co., Ltd. 永久	168
Fung Tien Electric Co., Ltd. 豐田	169
Great Go Cycle Inc. 偉兒達	170-171
Heming Inc. 鶴明	223
Heng Yen Enterprise Co., Ltd. 亨晏	227
Hsu Sheng Bicycle Ind. Co., Ltd. 旭生	174
Huang Wei Technology Enterprise Co., Ltd. 皇瑋	172-173
Jien Jien Mei Industry Co., Ltd. 健健美	175
Jintek Corporation. 金有達	176-177
Joy Tai Int'l Corp. 久鈦	178-179
Lightwave Bikes International 金日昇	180
Lung I Machinery Works Co., Ltd. 隴億	181
Lung Yangs Co., Ltd. 龍易	184
M&K Bicycles Ent. Co., Ltd. 名高	182-183
Maxway Cycles Co., Ltd. 一心	185
Mirt Design Co., 莫特	188
Ora Engineering Co., Ltd. 鈦郁	186-187
Song Zun Ind. Co., Ltd. 嵩雋	204-205
T&K Enterprise Co., Ltd. 武王	189
Ton Jin Technology Co., Ltd. 東偲	190-191
Twin-Frame Bicycle 秦純	192
Vision Bicycle Industry Co., Ltd. 威昇	193
Wei Chieh Bicycle Company Ltd. 煒捷	196
Woei Fong Machinery Works Co., Ltd. 隴峰	194-195
Ya-Heng Technology Co., Ltd. 亞恆	197
Yeong Fuh Bicycle Ind. Co., Ltd. 永富	198-199
Yoan Technologies Co., Ltd. 侑圓	200

## Overseas Manufacturers

Ansheng Precision Metal Products Co., Ltd. 安笙-太倉	202-203
Olympic Pro Manufacturing(Vietnam) Co., Ltd. 建興	201
Ping Chi Bicycle Parts (S.Z.) Co., Ltd. 品琦-深圳	206-207

## Brand Companies

Anasazi Sports Taiwan, Ltd. 勁馬	159
Apex Creative Co., Ltd. 峯境	214
Aresa International Co., Ltd. 宥威	208-209
Armor Manufacturing Corp. 鐵甲	210-213
Otc Tec Int'l Co., Ltd. 國泰鑫	215
Shine Wheel Ind. Corp. 耀輪	216-217

Sunny Crown Enterprises Co., Ltd. 蔣光燦	219
Top Venturer International Limited 大越傑樂	218
Venzo Cycle Co., Ltd. VENZO	220-222
Yon Gd International Co., Ltd. 宇衡	224-226
Yotec Int'l Ltd. 德耀	229

## B02 Front Forks

Acecast Industrial Co., Ltd. 克佳	248-249
Adk Technology Limited 勝捷	254
Aprebic Ind. Co., Ltd. 育華	250-253
Bev Int'l Corp. 精創	255
Cheng Yi Ent. Co., Ltd. 鉦鈺	256-257
Hexin Precision Co., Ltd. 和新	297
Hung Chan Ent. Co., Ltd. 紘展	259
Jiun Yih Bicycle Ind. Co., Ltd. 竣益	260-265
Kai Cheng Bicycle Parts Co., Ltd. 鏗誠	266-271
Kind Shock Hi-Tech Co., Ltd. 凱薩克	276
Kind Shock Hi-Tech Co., Ltd. 凱薩克	1170
Liang Feng Machine Co., Ltd. 良豐	272-273
Liwang Precision Co., Ltd. 立旺	274-275
Lung I Machinery Works Co., Ltd. 隴億	277
Magura Asia Limited Co., Ltd. 瑪古拉	Inside Back Cover
Mekkem Industrial Inc. 玄耕	278-279
Pin Fu Corporation 品賦	285
Rst Greenergy Tech. Co., Ltd. 金毅達	280-281
Sr Suntour Inc. 榮輪	282-284
Tung Fa Ind. Co., Ltd. 同發	286
Wan Der Ful Co., Ltd. 萬得富	298
Wuler Bicycle Ind. Co., Ltd. 伍樂	287
You Shun Ind. Corp. 裕順	288-290

## Overseas Manufacturers

HI Corp (Shen Zhen) 信隆-松崗	292-296
Shenzhen Mozo Technology Co., Ltd. 摩大	291

## B03 Front Fork Stems

Gemini Bicycle Inc. 展暉	302
Miing Huei Profit Co., Ltd. 銘輝	300-301
Nan Long Bicycle Material Co., Ltd. 南隆	303

## B04 Tubes/Tubing

Advanced Forming Technology Co., Ltd. 東余	304-305
A-Forge Ent. Co., Ltd. 九川天成	306
Founder Land Co., Ltd. 逢聯	307
Hua Hsines Ind. Co., Ltd. 華承	308-310
Satin Technology Co., Ltd. 京呈	311
Shuz Tung Machinery Ind. Co., Ltd. 旭東	1171
Tange International Co., Ltd. 丹下	313

## Overseas Manufacturers

Sanlead Metal (S.Z.) Co., Ltd. 昇勵-深圳	314-315
--------------------------------------	---------

# Frames & Frame Parts



## B05 Lugs/Shells

Allotec Co., Ltd. 晶鑫	316
Ec Head Tube Industrial Co., Ltd. 一昌	317
Hsiang Huang Ent. Co., Ltd. 祥煌	318



## B07 Rear / Dropouts

A-Forge Ent. Co., Ltd. 九川天成	322-325
Jiang Ding Technologies Co., Ltd. 將頂	319-321
Liow Ko Co., Ltd. 六哥	326-327



## B09 Head Parts

Chin Haur Ind. Co., Ltd. 清豪	328-329
First Bicycle Components Co., Ltd. 輪鋒	330
Fpd Industry Corp. 豐德	331
Mytec-Bike Co., Ltd. 明躍	332
Neco Technology Industry Co., Ltd. 誌慶	334-335
Tange Seiki Co., Ltd. 日亞丹下	336-337
Yantec Industries Inc. 元城	338-339



## B10 Bottom Bracket Parts

Chin Haur Ind. Co., Ltd. 清豪	340
Neco Technology Industry Co., Ltd. 誌慶	341



## B11 Seat Posts/Clamps

12o'clock Inc 澄泰	342
Bev Int'l Corp. 精創	343
Bo Well Enterprise Co., Ltd. 博緯	344-345
Chuan Ma Inc. 軒馬	346
Chuhn-E Industries Co., Ltd. 駿鎰	347
HI Corp (Tai Wan) 信隆	348-349
Kalloy Ind. Co., Ltd. 金亨	353
Kind Shock Hi-Tech Co., Ltd. 凱薩克	358
Kind Shock Hi-Tech Co., Ltd. 凱薩克	1172
Lee Chi Enterprise Co., Ltd. 利奇	1173-1175
M. J. Cycle International Co., Ltd. 猛進	354-355
Moderne Tech Corporation 安大	356-357
S.D. Components Co., Ltd. 鑫昇鼎	359
Shye Horng Enterprise Co., Ltd. 翊弘	360
Taiwan Chengfeng Precision Technology Co., Ltd. 誠鋒	361
Wan Der Ful Co., Ltd. 萬得富	363



## Overseas Manufacturers

HI Corp (Shen Zhen) 信隆-松崗	350-352
---------------------------	---------



## Brand Companies

Progressive Cycles Co., Ltd. 宇丞	362
---------------------------------	-----



## B12 Ball Retainers

Cw Bearing Taiwan Co., Limited 台慈	364
Gau Sheng Feng Industrial Co., Ltd. 高聖峰	365
Hope Industrial Corporation 合普	366-367
Hopmore Ind. Co., Ltd. 呈茂	368
Hsin Tung Metal Works 新東	369

Hwan Maw Ind. Co., Ltd. 環茂	370
Maxton Trading Company Ltd. 邁仕登	371
Taiwan Jiali Transmission Co., Ltd. 台灣嘉利	374
Tung-I Hardware Co., Ltd. 通溢	372-373
Young Sing Ball Bearing Co., Ltd. 永興軸承	375



## B13 Steel Balls

Jeng Ker Industrial Corp. 正錫鋼珠	376
Yuan Sheng Loo Machinery Co., Ltd. 源盛爐	377



## B14 Bolts/Nuts/Quick Releases/Pegs

Chin Jia Metal Co., Ltd. 錦佳	378-380
Ching Shing Precise Technology Co., Ltd. 慶興	381
Chuan Fu Screw Co., Ltd. 銓富	382
Ful Chee Ent Co., Ltd. 富錫	384-385
Ga-E Industrial Precision Co., Ltd. 鋼義	383
Gen Yaw Industry Co., Ltd. 景耀	386-388
Handle Development Co., Ltd. 佑嘉	389
Hang Kuang Hardware Ent. Co., Ltd. 漢光	390-392
Hi-Bike Ltd. 家豐榮	393
Jiunn Cherng Co., Ltd. 駿成	394-397
Laminar Ent. Co., Ltd. (Lagear Ind./ Prime Aero) 禾誌	398-399
Runlux Hardware Co., Ltd. 立輪	402
Shun Xin Co., Ltd. 舜新	400-401
Songtai Industrial Co., Ltd. 嵩鈺	403
Spin Up Hardware Technology Co., Ltd. 沛昌	404
Sutech Ent. Co., Ltd. 鉅特	405
Tai Lou Metal Industry Co., Ltd. 台螺	406
Yunnex Hardware Co., Ltd. 勇義	407



## Overseas Manufacturers

Dongguan Sanhewlett Metal Products Co., Ltd. 東莞三合利	408-409
Warder (Shenzhen) Co., Ltd. 仲旺-深圳	410



## B15 Frame Fittings

Blue Bird Metal Co., Ltd. 立銘	230-231
Coloury Enterprise Co., Ltd. 優品	234
Jueson Lai Enterprise Co., Ltd. 久陞	232-233
Kuomex Ind. Co., Ltd. 鑫德合	235
U-Logis Co., Ltd. 友穎商通	236-241
Yozu Metal Co., Ltd. 友誌	242-246



## B16 Pegs

Gemini Bicycle Inc. 展暉	411
Sheng Chuan Int'l Development Co., Ltd. 勝全	412
Taiwan Chengfeng Precision Technology Co., Ltd. 誠鋒	413



## Brand Companies

Jia Guang Enterprise Co., Ltd. 加廣	299
-----------------------------------	-----

### M9107 275+ / HARDTAIL PLUS

Material : Carbon  
MFG.Method : Monocoque  
Size : 17" / 19" / 21"  
Headset : 1-1/8" x 1.5"(FSA NO.42-ACB)  
FD : Direct mount  
Seatpost : ø31.6mm  
BB : PF30 / 73mm  
Dropout : Post Mount  
Rear Hub : 12 x 148 E-thru  
Tire : 27.5" x 2.8" / 29" x 2.0"  
Weight : 1000g (17")



### ERDP 6.0A 275+ / E-FULLY AM

Material : Aluminum # 6061  
MFG.Method : Flat Welding + Tig Pulse  
Size : 15.5" / 17" / 18.5" / 20"  
Headset : 1-1/8" x 1.5"(FSA NO.57)  
Seatpost : ø30.9mm  
Electric system : Available in BOSCH / SHIMANO System  
Dropout : Post mount  
Rear Hub : 12 x 148 E-thru  
Tire : 27.5" x 2.8" / 29" x 2.0"  
Travel : 6" / 150mm  
Shock Bushing : upper 30mm / ø8  
lower 30mm / ø8  
Shock Length : 215mm / 63mm  
Weight : 3500g (17" w/o Shock)



### EM9107-B 275+ / E-HARDTAIL

Material : Carbon  
MFG.Method : Monocoque  
Size : 15" / 17" / 19" / 21"  
Headset : 1-1/8" x 1.5"  
FD : Direct Mount  
Seatpost : ø30.9mm  
Electric system : BOSCH system  
Dropout : Post mount  
Rear Hub : 12 x 148 E-thru  
Tire : 27.5" x 2.8" / 29" x 2.0"  
Weight : 1700g (17")



### EG-40 / E-FULLY GRAVEL 40

Material : Aluminum # 6061  
MFG.Method : Smooth welding  
Size : 49 / 52 / 54 / 56 / 59  
Headset : 1-1/8" x 1.5" FSA NO.42-ACB  
Seatpost : ø27.2mm  
Electric system : FAZUA system  
Dropout : Flat Mount  
Rear Hub : 12 x 142 E-thru  
Tire : 27.5" x 2.0" / 700 x 40C  
Travel : 40mm  
Shock Length : 150 / 15mm  
Shock Bushing : upper 22mm / ø8  
lower 22.2mm / ø8  
Weight : 2300g (17" w/o Shock)



### SPT 6.0C 275+ / FULLY AM

Material : Carbon  
MFG.Method : Monocoque  
Size : 16" / 18" / 20"  
Headset : 1-1/8" x 1.5"(FSA NO.42-ACB)  
ST FD : Direct Mount / Di2 Available  
Seatpost : ø31.6 mm  
BB : SHIMANO BB92  
Dropout : Post Mount  
Rear Hub : 12 x 142mm E-thru  
12 x 148 mm (Optional)  
Tire : 27.5" x 2.8" / 29" x 2.0"  
Travel : 6" / 150mm  
Shock Bushing : upper 22.2mm / ø8  
lower 22.2mm / ø8  
Shock Length : 215 / 63mm  
Weight : 1700g (18" w/o shock)



### RDP 5.5C 275+ / FULLY AM

Material : Carbon  
MFG.Method : Monocoque  
Size : 16" / 18" / 20"  
Headset : 1-1/8" x 1.5"(FSA NO.42-ACB)  
ST FD : Direct Mount  
Seatpost : ø31.6 mm  
Dropout : Post Mount  
Rear Hub : 12 x 142mm E-thru  
Tire : 27.5" x 2.8" / 29" x 2.0"  
Travel : 140mm  
Shock Bushing : upper 22.2mm / ø8  
lower 22.2mm / ø8  
Shock Length : 210 / 55mm  
Weight : 1700g (18" w/o shock)





**Model: KSFM28**

Type: 29" MTB  
Size: 15/17/19/21"(C-T)  
Headset: FSA NO.42/ACB  
Weave: UDM Carbon Weave  
Level: Regular available  
BB: BSA/BB92-89.5mm version  
Seat Post: KSSP07(31.6mm)



**Model: KSFM27**

Type: 700C ROAD  
Size: 48/50/52cm(C-T)  
Headset: FSA NO.42/ACB  
Weave: UDM Carbon Weave  
Level: Regular available  
BB: BSA/BB86/BB386 version  
Seat Post: KSSP09  
Fork: Optional===>KSF024-MC



**Model: KSFM26**

Type: 700C ROAD  
Size: 48/50/52/54/56/58cm(C-T)  
Headset: FSA NO.42/ACB  
Weave: UDM/Textreme Carbon Weave  
Level: Regular /SL available  
BB: PF30 version  
Seat Post: KSSP05(27.2mm)  
Fork: Optional===>KSF015-MC  
Exclusivity in ITALY



**Model: KSFM25**

Type: 700C ROAD  
Size: 48/50/52/54/56cm(C-T)  
Headset: FSA NO.42/ACB  
Weave: UDM Carbon Weave  
Level: Regular available  
BB: BB86/BB386 version  
Seat Post: KSSP08  
Fork: Optional==>KSF009-MC



**Model: KSFM24**

Type: 700C ROAD  
Size: 47/50/52/54/56cm(C-T)  
Headset: FSA NO.42/ACB  
Weave: UDM Carbon Weave  
Level: Regular available  
BB: BB386 version  
Seat Post: KSSP08  
Fork: Optional==>KSF004-MC



**Model: KSFM22**

Type: 700C ROAD DISC FLAT MOUNT  
Size: 48/50/52/54/56cm(C-T)  
Headset: FSA NO.42/ACB  
Weave: UDM Carbon Weave  
Level: Regular available  
BB: BB386 version  
Seat Post: KSSP08  
Fork: Optional==>KSF002-FC

**NEW E-ROAD**
**MODEL: AKFM37**

Type: E-BIKE  
 Size: 52/55/58cm(C-T)  
 Headset: FSA NO.42/ACB  
 Weave: UDM Carbon Weave  
 Level: Regular available  
 Motor: FAZUA  
 Seat Post: AKSP10(27.2mm)  
 Fork: Optional==>AKF074  
 Exclusivity in ITALY

**MODEL: AKFM32**

Type: 700C ROAD DISC FLAT MOUNT  
 Size: 48/51/54/57/60cm(C-T)  
 Headset: FSA NO.42/ACB  
 Weave: UDM Carbon Weave  
 Level: Regular/SL available  
 BB: BB86 version  
 Seat Post: AKSP09  
 Fork: Optional==>AKF054-FC  
 Exclusivity in UK

**Model: AKFM31**
**NEW**

Type: Gravel  
 Size: 46/49/52/55cm(C-T)  
 Headset: FSA NO.42/ACB  
 Weave: UDM Carbon Weave  
 Level: SL available  
 BB: BB386 version  
 Seat Post: AKSP10(27.2mm)  
 Fork: Optional==>AKF071  
 Exclusivity in UK

**MODEL: KSFM32**

Type: 700C ROAD  
 Size: 45/47/50cm(C-T)  
 Headset: FSA NO42/ACB  
 Weave: UDM Carbon Weave  
 Level: Regular available  
 BB: BB86 version  
 Seat Post: KSSP12  
 Fork: Optional==>KSFO09-MC

**MODEL: KSFM31**

Type: 700C ROAD T/T  
 Size: 50.7/52.3/54.8/57.4cm(C-T)  
 Headset: FSA IS2  
 Weave: UDM Carbon Weave  
 Level: Regular available  
 BB: BB386 version  
 Seat Post: KSSP11  
 Fork: Optional==>KSFO30  
 H/B: KSHB09

**MODEL: KSFM29**

Type: 29" MTB  
 Size: 16"/18"/20"(C-T)  
 Headset: FSA NO.55  
 Weave: UDM Carbon Weave  
 Level: Regular available  
 BB: BB92 version  
 Seat Post: KSSP07(31.6mm)





**Model:** AKFM30  
**Type:** T.T 700C\*23  
**Size:** S/M/L/XL  
**Headset:** FSA IS2  
**Weave:** UDM Carbon Finish  
**Level:** Regular available  
**BB:** BB86 version  
**Seat Post:** AKSP07  
**Handle Bar:** AKHB08  
**Fork:** Optional==>AKF049-MC  
 Exclusivity in Germany



**Model:** AKHB01  
**Type** SL(Racing only)  
 RE(Racing and TT aero bar compatible)  
**Dia** Oversize  
**Available** 31.8  
**Length** 400/420/440mm(C to C)  
**Weave** SL in full 3K Weave  
 RE(TT)/3K in the middle



**Model:** AKHB04  
**Type** SL(Racing only)  
 CE(Racing and TT aero bar compatible)  
**Dia** Oversize  
**Available** 31.8  
**Length** 380/400/420/440mm(C to C)  
**Weave** SL in full 3K Weave  
 CE(TT)/3K in the middle



**Model:** AKHB10  
**Type** MTB bar  
**Dia** Oversize  
**Available** 31.8  
**Length** 760/780/800mm  
**Weave** UDM Carbon Weave

**NEW**



**Model:** AKHB05(Flat)  
**Type** MTB bar  
**Dia** Oversize  
**Available** 31.8  
**Length** 720/740/760mm  
**Weave** 3K/UDM Carbon Weave



**Model:** AKHB06(Riser)  
**Type** MTB bar  
**Dia** Oversize  
**Available** 31.8  
**Length** 720/740/760mm  
**Weave** 3K/UDM Carbon Weave



**Model:** AKHB07(Flat)  
**Type** MTB bar  
**Dia** Oversize  
**Available** 31.8  
**Length** 720/740/760mm  
**Weave** 3K/UDM Carbon Weave



# OEM & ODM



**X-ZENITH/ SP-XS4.0SL**  
 CARBON SEATPOST Super Light  
 DIAMETER : 27.2/30.9/31.6 (mm)  
 OFFSET: 15°  
 LENGTH:350/400(mm)  
 WEIGHT: **162g (31.6/350mm)±10g**



**X-ZENITH/ SP-XS3.0SL**  
 CARBON SEATPOST Super Light  
 DIAMETER:27.2/30.9/31.6(mm)  
 OFFSET: 0°  
 LENGTH: 350/400 (mm)  
 WEIGHT: **149g (27.2/350mm)±10g**



**ST-SX2.0SL**  
 CARBON FULL Super Light  
 Steerer: 28.6mm.Steerer Height:40mm  
 ANGLE ±6°  
 BOLTS:TITANIUM  
 SIZE: 80/90/100/110/120/130mm  
 WEIGHT : **100g (80mm)±5g**



**X-ZENITH/HB-RD4.0**  
 CARBON FULL  
 Reach:80mm/Drop mm :120mm  
 WIDTH : 360/380/400 (mm)  
 WEIGHT :208g(380mm)±10g



**X-ZENITH/HB-RD8.0**  
 CARBON FULL New:OUTER:4°  
 Reach:77mm/Drop :125mm  
 WIDTH:380/400/420/440 (mm)  
 WEIGHT :211g(400mm)±10g



**FM-RA06**  
 ROAD AERODYNAMICS  
 FULL CARBON  
 Size: 466/485/500/515/531/562 mm  
 BB: BB86  
 Frame Weight: 500 mm/ 1026g±50g  
 Fork Weight: 368g±20g  
 Seatpost Weight: 238g±20g  
 Maximum Tire: 30mm



**FM-292 29ER**  
 FULL Carbon  
 O.L.D.:142°12/135°10  
 Di2 FD: Side Swin / EPS  
 BB:BB92/BSA/PF30  
 Size:15.5°/17.5°/19°/21°



**FM-D15**  
 ROAD DISC AERODYNAMICS  
 FULL CARBON  
 Flat Mount Type  
 Fork: QR or Thru-Axle  
 Size: 466/485/500/515/531/562 mm  
 BB: BB86  
 Frame Weight: 500 mm/ 1056g±50g  
 Fork Thru-Axle Weight: 400g±20g  
 Seatpost Weight: 228g±20g  
 Interchangeable dropouts:  
 135°QR10mm & 142°thru axle 12mm  
 Maximum Tire:30mm



**FM-TT1**  
 TT FULL CARBON  
 Frame with post mount brake  
 Fork with V-brake  
 Size: 45/49/52/54/56CM  
 Stem 75mm/ Aerobar 420mm  
 Armrest Width 329mm/  
 Seatpost 350mm  
 BB: BSA/BB30/PF30  
 Frame + Fork Weight:  
 45CM/2370g±50g  
 Seatpost Weight: 260g±10g  
 Maximum Tire : 25mm



**FM-CG1**  
 GRAVEL FULL CARBON  
 Flat mount type  
 Size: 47/50/53/56/59CM  
 Seatpost Size: Ø27.2 mm  
 BB: BB86  
 Frame Weight: 53CM/1055g±50g  
 Fork Weight: 496g±20g  
 Interchangeable dropouts  
 135°QR10mm & 142°thru axle12mm  
 Tire Range:  
 700\*45C 27 5\*2.25



**FM-RCM**  
 GRAVEL FULL CARBON  
 BB CAN BE ROTATED  
 Flat mount type  
 Fork: QR or Thru-Axle  
 Size: 47/50/53/56/59CM  
 Seatpost Size: Ø27.2  
 BB: BB386/BB86  
 BB in Combination of road & mountain function  
 Frame Weight: 53CM/ 1280g±50g  
 Fork Weight: 500g±20g  
 Interchangeable dropouts:  
 135°QR10mm & 142°thru axle 12mm  
 Tire Range:  
 700\*45C 29°1.95 27.5\*2.25

Taiwan  
 P.A.T. 1602732  
 P.A.T. 1602733



X1 GR 27.5+ XT 11



RCM: MTB XT 11



RCM: Road: Force 11

# TITANOS

# AGOGO

OEM & ODM SERVICE / CUSTOM MADE  
 We are a factory with 40 years' experience of assembling bicycles.  
 We supply bicycles and components.

ADD: NO. 489-10, SHIDE RD., WUFENG DIST., TAICHUNG CITY 41356, TAIWAN  
 TEL: +886-4-23398592 FAX: +886-4-23339459

[www.titanosbike.com](http://www.titanosbike.com)  
[www.agogobike.com](http://www.agogobike.com)

E-mail: [service@agogobike.com](mailto:service@agogobike.com)





**ALU MEGA INDUSTRIAL CO., LTD.**

**鋁大股份有限公司**

TEL:886-37-861151 / FAX:886-37-866191

E-mail: alu.maga@msa.hinet.net

35865 苗栗縣苑裡鎮新復里新復1-6號

No, 1-6 Xinfu, Yuanli Township,

Miaoli County 35865, Taiwan



**OM-02**

MTB, E-Bike for FAZUA



**EB-OM1**

E-Bike for FAZUA



**EB-03**

E-Bike for SHIMANO E8000



**RD-OM1**

Road, E-Bike for FAZUA



**EB-HL1**

E-Bike for PMSM Motor

**Advanced Monocoque**  
**MONOLITH** Production Technology



**ANASAZI SPORTS TAIWAN, LTD.**

NO. 141 GUO'AN 1ST ROAD, XITUN DISTRICT, TAICHUNG CITY 40763, TAIWAN

TEL: +886-4-2463-6980 / 2452-3291    FAX: +886-4-2452-1968    E-MAIL: [vincent.c1900@mail2000.com.tw](mailto:vincent.c1900@mail2000.com.tw)

HIGH STRENGTH · CUSTOM SPECS · LIGHTWEIGHT



# 安吉特科技有限公司

Arkiotech Engineering

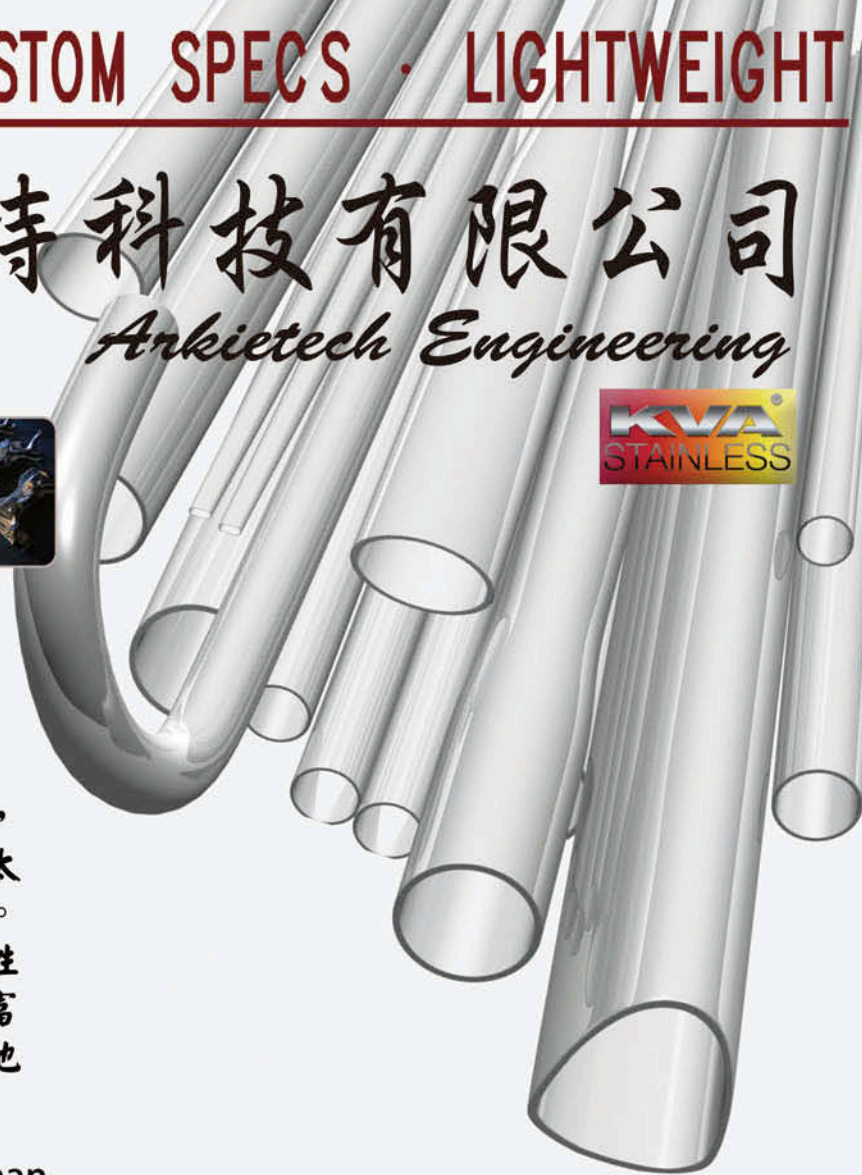
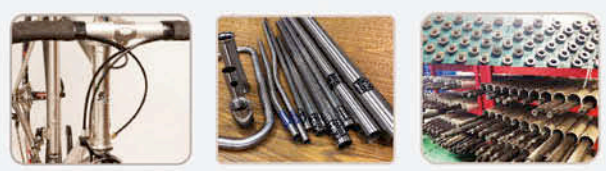

安吉特科技有限公司位於台灣台南市，專研各式材質管件加工，產業含括航太、醫療、汽機車、自行車、運動器材。我們的管材具備高強度、輕量化等特性，提供客戶客製化服務，憑藉經驗豐富的團隊，產出優質的管件銷售世界各地，歡迎隨時與我們聯繫。

Arkiotech Engineering is located in Tainan, Taiwan. We specialize in producing various metal tubing for the medical, sports, automobile and bike industries. Our focus is to provide a range of high-end, light-weight, and economical tubes for companies worldwide.

With a team of metal and fabrication experts, we also offer unique steels and make custom-shape tubing. Feel welcome to contact us for questions or inquires. We are open for new product development and OEM services.

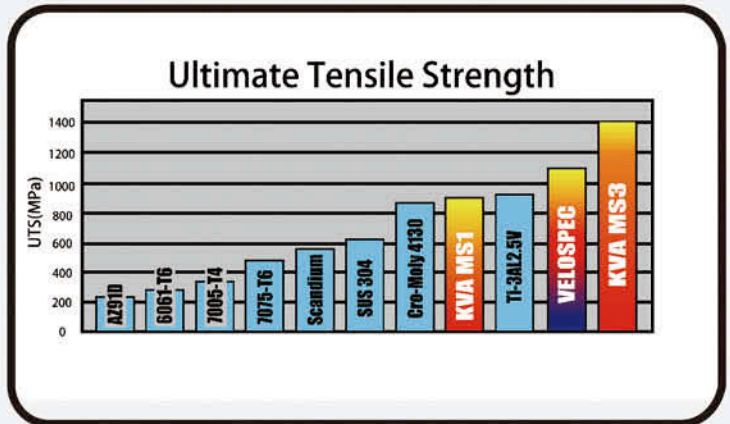

LINE QR CODE



WEB QR CODE



安吉特科技有限公司 Arkiotech Engineering

TEL : 886-6-5938638

FAX : 886-6-5939646

WEBSITE : WWW.ARKIETECH.COM

EMAIL : INFO@ARKIETECH.COM



### 007 DISC 700C ROAD DISC

- BB86
- DC2 TECHNOLOGY
- INNER CABLE ROUTING
- HEADSET:UPPER 1-1/8"  
LOWER 1-1/2"
- SIZE:46/49/52/55/58CM
- THROUGH-AXLE:M12x142



### F35 700C ROAD

- BB86
- INNER CABLE ROUTING
- HEADSET:UPPER 1-1/8"  
LOWER 1-1/2"
- SIZE:45/48/51/54CM



### 007 700C ROAD

- BB86
- DC2 TECHNOLOGY
- INNER CABLE ROUTING
- HEADSET:UPPER 1-1/8"  
LOWER 1-1/2"
- SIZE:46/49/52/55/58CM



### F1 700C ROAD

- BB86
- INNER CABLE ROUTING
- HEADSET:UPPER 1-1/8"  
LOWER 1-1/2"
- SIZE:47/50/53/56CM



### CONTENDER 700C ROAD

- BB86
- DC2 TECHNOLOGY
- INNER CABLE ROUTING
- HEADSET:UPPER 1-1/8"  
LOWER 1-1/2"
- SIZE:43/45/47/50CM



### A610 700C ROAD

- BB86
- INNER CABLE ROUTING
- HEADSET:UPPER 1-1/8"  
LOWER 1-1/2"
- SIZE:39/46/49/52/55CM



### AM75 27.5 MTB

- BB92
- INNER CABLE ROUTING
- HEADSET:UPPER 1-1/8"  
LOWER 1-1/2"
- SIZE:15.5"/16.5"/18"
- THROUGH-AXLE:M12x142

ASTER TECHNOLOGIES



### SHE-706

Shimano STEPS, Available in E5000, E6100  
 BT-E6001 504Wh (36V, 14Ah)  
 BT-E6000 418Wh (36V, 11.6Ah)  
 Shimano Nexus 7sp.

SHIMANO  
STEPS



### SHE-708L

Shimano STEPS, Available in E6100, E7000  
 BT-E6010 418Wh (36V, 11.6Ah)  
 Shimano Alivio

SHIMANO  
STEPS

**SHE-708G**  
 Special Cable Routing for Electric Bike  
 TYPE Custom design for Shimano STEPS Alloy Frame  
 SIZE All Custom Geometry  
 FRAME Alloy 6061



### SHE-200

Shimano STEPS, Available in E5000, E6100  
 BT-E6010 418Wh (36V, 11.6Ah)  
 BT-E8010 504Wh (36V, 14Ah)

SHIMANO  
STEPS



### SHE-202

Shimano STEPS, Available in E5000, E6100  
 BT-E6000 418Wh (36V, 11.6Ah)  
 BT-E6001 504Wh (36V, 14Ah)

SHIMANO  
STEPS



## We offer total Solution of Mid-Motor

Frame

E-Kits

Complete Bike

■ In-house Design



**SHE-961** 29"

SHIMANO  
STEPS

BOSCH

MPP DRIVE

BAFANG



**SE8-542**

■ Also available for Shimano E7000



## BIXETEC INTERNATIONAL CO.,LTD.

No.100, Boguan 3rd St., West DIST., Taichung City 40353, Taiwan  
 TEL + 886-4-23203928 FAX + 886-4-23204181

E-mail: kevin@bixetec.com Web: www.ballistic.com.tw Fb: www.facebook.com/ballistic.tw

**SHE-561** In Frame Battery  
 27.5" STEPS Full Suspension Frame  
 Alloy 6061



**SHE-960**  
 29" STEPS Frame  
 Alloy 6061



**SHE-706-1**  
 700C STEPS Frame  
 Alloy 6061



**SE8-748L**  
 700C STEPS Frame  
 Alloy 6061



**SE8-748G**

**SHE-709-1**  
 700C STEPS Frame  
 Alloy 6061



**SHE-705 Belt**  
 700C STEPS Frame  
 Alloy 6061



 CARBON DRIVE



**SHE-702**  
 700C STEPS Frame  
 Alloy 6061



**SHE-200**  
 20" STEPS Folding Frame  
 Alloy 6061



**BIXETEC INTERNATIONAL CO., LTD.**

No.100, Boguan 3rd St., West DIST., Taichung City 40353, Taiwan  
 TEL + 886-4-23203928 FAX + 886-4-23204181

E-mail: kevin@bixetec.com Web: www.ballistic.com.tw Fb: www.facebook.com/ballistic.tw





**New**

**New**



▲ BCG-269  
Cargo bike, front 20" disc brake,  
rear 24" V brake, alloy frame



▲ BCG-269-BK  
Cargo bike, front 20" disc brake,  
rear 24" V brake, alloy frame, Dapu motor



▲ BVR-095  
700c road racing frame, FM disc brake,  
dropout: QR type & 12\*142mm convertible,  
available in 45, 47, 50, 53, 56 & 59cm,  
matching fork: FRC-614

▲ BVR-097  
700c road frame, flat mount design,  
through axle 12\*142mm, in 47, 50, 53, 56  
& 59cm, matching fork: FRC-097

**New**

**New**



▲ BVT-062  
700c TT frame, caliper brake design,  
in 50, 52, 54, 56 & 58cm, including frame  
+ fork + seat post + stem + clamp

▲ BVC-7011  
Gravel racing, maxi.  
29\*1.95, in 49, 52, 54, 56 & 58cm



**New**

**New**

**New**

▲ BVC-096  
Gravel racing frame,  
PM disc brake, dropout:  
QR type & 12\*142mm  
convertible, available  
in 47, 50, 53, 56 & 59cm,  
matching fork: FCC-610

▲ BVM-063  
29er E-MTB in 17.5"  
for Bafang battery  
model MM G330.250

▲ BVM-069  
27.5+ suspension frame,  
in 15.5", 17.5" & 19",  
boost type

▲ BVM-083  
27.5+ hardtail carbon frame,  
available in S, M & L matching  
fork: FMC-702

▲ BVM-085  
650B+, M size, E-MTB for  
Shimano E8000



← BEC-Di2 open  
← BEC-4mm  
for 4mm derailleur housing



← BEC-Di2 close  
← BEC-5mm  
for 5mm brake housing



← BEC-Di2-ST  
Di2 oval close plug 7\*8mm  
← BEC-DISC-04  
plug for post mount disc  
brake 5mm holes

**New**

**New**



← Adapter-15\*100-110  
disc adapter for hub size  
15\*100 to 15\*110mm boost



← Adapter-12\*142-148  
disc adapter for hub size  
12\*142 to 12\*148mm boost

**New**



← BEC-Di2-DT  
Di2 oval close  
plug 13\*18mm

← BMT-002  
OK hanger tool to save your trip  
home when your hanger is broken



← Adapter-12\*148-157  
disc adapter for hub size  
12\*148 to 12\*157mm super boost



# LEADING to SUCCESS



carbotec



瑩信工業股份有限公司  
CARBOTEC INDUSTRIAL CO., LTD.  
TEL:886-4-26815316 FAX:886-4-26815326

台中市大甲區43769幼獅工業區工二路41號  
No.41,Kung 2nd Road, Youth Industrial Park, Tachia District,  
Taichung City, Taiwan 43769  
[www.carbotec.imb2b.com](http://www.carbotec.imb2b.com)

## WILD 8000

650B & 29"+650+ SHIMANO  
E8000 E-SUSPENSION  
FRAME

TRAVEL: 150MM REAR / 150MM FRONT  
MATERIAL: AL6061  
WEIGHT: 3.84 KG (Frame Only)  
SIZE: S/M/L/XL



## Cari-Flat KVA 0L

700C ROAD FRAME

MATERIAL: KVA Stainless (MS3 + MS1)  
or CR-MO  
WEIGHT: 1.8 KG  
SIZE: 52CM



※ Thru Axle + Flat Mount

## IBEX 650B WILD

650B BOOST SUSPENSION  
FRAME

TRAVEL: 143MM REAR / 150MM FRONT  
MATERIAL: AL6061  
WEIGHT: 3.04 KG  
SIZE: S/M/L/XL



## E-GO-PLUS

650B+ PINION GEARBOX  
HARDTAIL FRAME

MATERIAL: AL6061  
WEIGHT: 1.8 KG  
SIZE: M



## SPIRIT LUG

700C ROAD FRAME

MATERIAL:  
COLUMBUS SPIRIT/  
CR-MO+LUG  
WEIGHT: 1.86 KG  
SIZE: 53 CM



## QB-M650B

650B MTB FRAME

MATERIAL: AL6061  
WEIGHT: 1.8 KG  
SIZE: M





昌徽/永盛

**CHANG HUEI ENTERPRISE CO., LTD.**

No. 133-6, Sec. 1, Yuanlu Rd., Chiao Shu Tsun, Pu Yen Hsiang 516, Chang Hua, Taiwan

Tel: 886-4-8814460 Fax: 886-4-8820778

E-mail: kun-lun@umail.hinet.net



Model CH-0771  
Material: Cr-mo, Steel  
Size: 650b" 29"

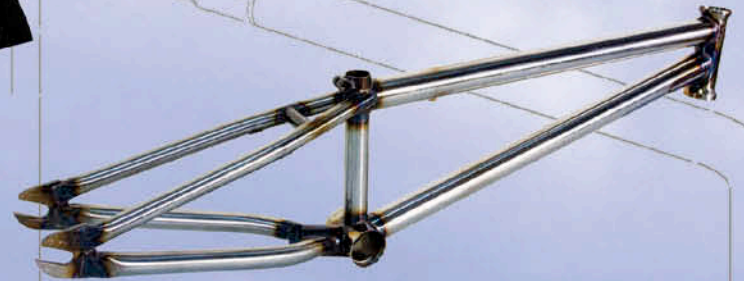

Model CH-0210  
Material: Cr-mo, Steel  
Size: 20"

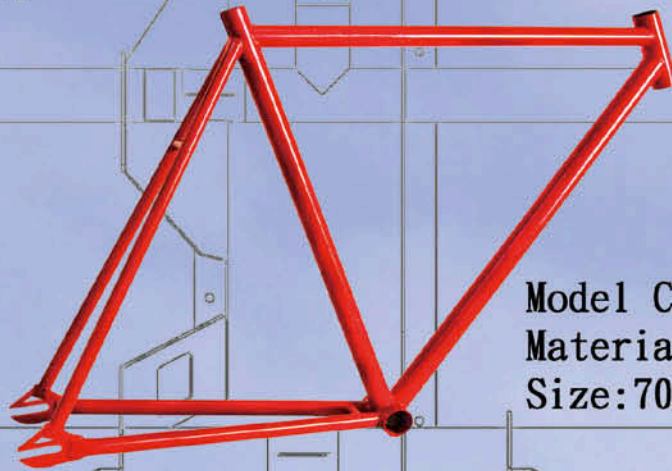

Model CH-0520  
Material: Cr-mo, Steel  
Size: 700C

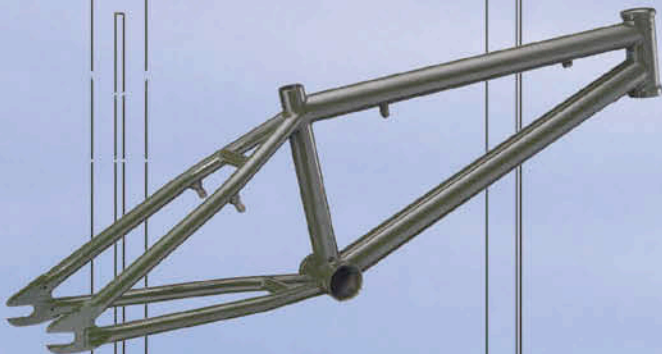

Model CH-0209  
Material: Cr-mo, Steel  
Size: 20"

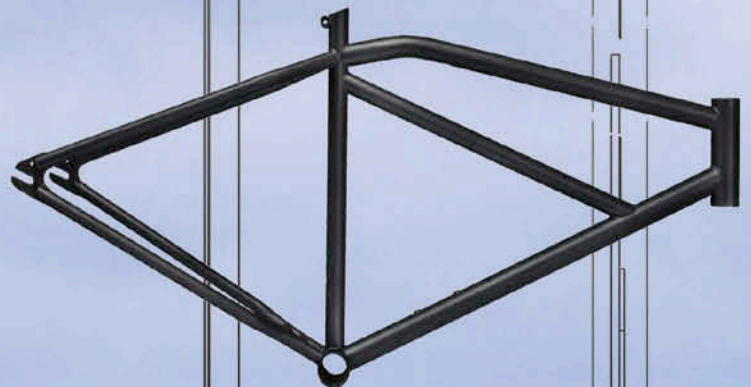

Model CH-0605  
Material: Cr-mo, Steel  
Size: 26"

# 永久機械工業股份有限公司

FOREVER MACHINE INDUSTRIAL CO., LTD.

TEL: +886-4-26879121  
FAX: +886-4-26874909

[www.forever-f1.com.tw](http://www.forever-f1.com.tw)  
[forever6@ms9.hinet.net](mailto:forever6@ms9.hinet.net)



CR-MO  
ALLOY  
TITANIUM  
REYNOLDS  
STAINLESS



**FE-AGAJ01**  
BMX / CR-MO 4130  
TITANIUM / STAINLESS 174

**FE-7FA01**  
700C / CR-MO 4130



FUNG TIEN ELECTRIC CO., LTD

NO. 10-1, Shin-YI Rd., An Ping Industrial Park, Tainan Taiwan.

Tel:886-6-2637366 Fax: 886-6-2617043

E-mail: barry@alftonbikes.com.tw/ jessica@alftonbikes.com.tw

B01



### 19AN-BOSCH-SUS

Type: 27.5" Suspension  
Material: AN6-Triple Butted  
Size: 17.0", 19.0", 21.0"  
Travel: 135mm  
Finish: Tig Weld



### 19AN-275F392AM

Type: 27.5" Suspension-All Mountain  
Material: AN6-Triple Butted  
Size: 17.0", 19.0", 21.0"  
Travel: 140mm  
Finish: Tig Weld



### 19AN-BROSE-SUS

Type: 27.5" Suspension-Enduro  
Material: AN6-Triple Butted  
Size: 17.5", 19.0", 20.5"  
Travel: 153mm  
Finish: Tig Weld



### 19AN-29F394B

Type: 29" Suspension-All Mountain  
Material: AN6-Triple Butted  
Size: 16.0", 18.0", 20.0"  
Travel: 138mm  
Finish: Tig Weld



### 19AN-XC-29E (Shimano E8000)

Type: 29" Suspension-All Mountain  
Material: AN6-Triple Butted  
Size: 17.0", 19.0", 21.0"  
Travel: 130mm  
Finish: Tig Weld



### 19AN-29F399

Type: 29" Suspension-All Mountain  
Material: AN6-Triple Butted  
Size: 16.0", 18.0", 20.0"  
Travel: 139mm  
Finish: Tig Weld



100%

SOLID CRAFTSMANSHIP



30% +

STRINGENT TESTING THAN ISO STANDARD

*Ride with*  
**TRIGON**



**30 +**

**YEARS EXPERIENCE**

**of MAKING CARBON FIBER BIKES**

[www.trigoncycles.com](http://www.trigoncycles.com)

[sales@trigonbike.com](mailto:sales@trigonbike.com)







QUALITY

PRECISION

TECHNIQUE

FOR THE PAST 20 YEARS, HUANG WEI HAS BEEN AT THE FRONT OF LEADING-EDGE FRAME FABRICATION FOR SOME OF THE MOST WELL-KNOWN BRANDS IN THE BICYCLE INDUSTRY. UTILIZING EXPERIENCE, THE LATEST SCIENCE, AND ADVANCED MACHINERY, HW IS ABLE TO OFFER TOP-NOTCH PRODUCTS THAT ARE SECOND TO NONE.

**HUANG-WEI TECHNOLOGY ENTERPRISE IS ISO-9001 CERTIFIED**

OUR TOTAL CUSTOMER SERVICE - FROM START TO FINISH:

FRAME INDUSTRIAL DESIGN | ENGINEERING AND EVALUATION | FABRICATION | QUALITY TESTS | GRAPHICS DESIGN | DECALS | PAINTING | PRODUCTION | SHIPPING | AFTER-SALES SERVICES (WARRANTY / ISSUES)

**AF7-202**

27.5 ALL-MOUNTAIN 4 BAR  
Head Tube: 1-1/8", 1-1/2"  
Seatpost Ø: 30.9mm  
Post Mount: 180  
Shock: 216/63mm  
Travel Switch: 140/160mm

**DROPPER SEATPOST COMPATIBLE**  
Dropper seatposts make descents more stable.

**140/180mm REAR TRAVEL**  
Gives the best balance of comfort and performance.

**INTERNAL CABLE ROUTING**  
Provides a clean and clutter-free premium look.



**6061 ALUMINUM**  
Proven strong, durable and lightweight.

**BOSCH CX DRIVE**

Offers 25% more torque than the regular Performance Line motor - up to 75 Nm at peak output. Ideal for the demands of eMTBs.



**MADE IN TAIWAN**  
Great quality, and even better value.



**HYDROFORMED TUBES**

**AF7-203**

27.5 + ENDURO 4 BAR  
6061 aluminium | Head Tube: 1-1/8", 1-1/2" |  
Seatpost Ø: 30.9mm | Post Mount: 180 |  
Shock: 200/57mm | Rear Travel: 140mm |  
BSA 68/73mm

**AF7-204**

27.5 AM 4 BAR  
6061 aluminium | Head Tube: 1-1/8", 1-1/2" |  
Seatpost Ø: 30.9mm | Post Mount: 180  
| Shock: 200/57mm | Rear Travel: 160mm  
| BSA 68/73mm

- DROPPER SEATPOST COMPATIBLE
- 29ER X 2.3" COMPATIBLE
- INTERNAL CABLE ROUTING

- DROPPER SEATPOST COMPATIBLE
- REMOVABLE FD MOUNT
- INTERNAL CABLE ROUTING
- DA/DM HANGER COMPATIBLE



**NEW TRUNNION SHOCK MOUNT**

In metric sizes to accommodate the newest standards

**HIGHLY EFFICIENT SUSPENSION KINEMATICS**

With optimized leverage progression for superior suspension quality on all kind of terrain

**OVERSIZE ROCKER BEARINGS**

Maximize stiffness and durability

**DOUBLE BALL BEARINGS**

On all rear triangle connections for superior stiffness and durability



**RESTRAINED DERAILLEUR MOUNT**

In case the frame needs to be specified for use with a derailleur

**27.5PLUS 4BAR S1**

DEVELOPED IN COOPERATION WITH GERMAN BICYCLE DESIGNER STEFAN STARK OF STS BIKE DESIGN

**TRAIL**

Sizes (mm): 41 / 44 / 47 / 50

Head Tube: 1-1/8", 1-1/2"

Seatpost Ø: 30.9mm

Bottom Bracket: BSA 73

**148X12 BOOST DROPOUT**

Boost chainline allows a much stiffer chain stay yoke



**FC986 ROAD**

6061 aluminium | Sizes (mm): 44 / 47 / 50 / 53 / 56 | Head Tube: 1-1/8", 1-1/2" | BSA 68 | Dual-pivot brakes | Vertical 130mm drop-out



**GP97 ROAD**

6061 aluminium | Sizes (mm): 44 / 47 / 50 / 53 / 56 | Head Tube: 1-1/8", 1-1/2" | Seatpost Ø: 31.6mm | BSA 68 | Flat mount brakes | E-thru 142mm x 12mm drop-out



**WANT TO KNOW MORE?**

THE PRODUCTS ON THESE PAGES ARE JUST A FEW EXAMPLES OF WHAT WE CAN DO FOR YOU. WHETHER YOU'RE INTERESTED IN OUR DESIGNS OR YOU HAVE YOUR OWN DESIGNS. CONTACT US!

**HUANG WEI TECHNOLOGY ENTERPRISE CO., LTD.**

皇 瑋 科 技 企 業 有 限 公 司

No.8-1,Lane 101,Nanbei 8th Rd.,Da-an District Taichung City 439,Taiwan  
Tel +886-4-26882543 | Fax+886-4-26889002 | huang.kuomiu@msa.hinet.net

[WWW.HW-WELDING.COM.TW](http://WWW.HW-WELDING.COM.TW)



**HUANG WEI**

QUALITY . PRECISION . TECHNIQUE



# SUNRISE

## H99927EBAA 1442A

E-MTB 27.5+  
SHIMANO E8000 SYSTEM  
Intergrated battery  
Taper HT O.L.D 148mm  
Thru-Axle M12\*P1.5  
Metercial AL-6061-T6



## H99927EBAA 1542A

E-MTB 27.5+  
Bosch SYSTEM  
Intergrated battery  
Taper HT O.L.D 148mm  
Thru-Axle M12\*P1.5  
Metercial AL-6061-T6



## H99927EBAA 1642A

E-SUSPENSION AM 27.5+  
SHIMANO E8000 SYSTEM  
Intergrated battery  
Taper HT O.L.D 148mm  
Thru-Axle M12\*P1.75  
Wheel travel 140mm  
Metercial AL-6061-T6



## H99927EBAA 1742A

E-SUSPENSION AM 27.5+  
Bosch SYSTEM  
Intergrated battery  
Taper HT O.L.D 148mm  
Thru-Axle M12\*P1.75  
Wheel travel 140mm  
Metercial AL-6061-T6



## H99927EBAA 1842A

E-SUSPENSION ED 27.5+  
Bosch SYSTEM  
Intergrated battery  
Taper HT O.L.D 148mm  
Thru-Axle M12\*P1.75  
Wheel travel 160mm  
Metercial AL-6061-T6



**旭生自行車工業股份有限公司 HSU SHENG BICYCLE INDUSTRIAL CO.,LTD**

台中市大甲區通天路 139 號

NO139, Tongtian Rd., Dajia Dist., Taichung City, Taiwan

旭生機械(深圳)有限公司 HSU SHENG MACHINERY(SHENZHEN) CO.,LTD

廣東省深圳市寶安區松崗街道東方社區大田洋工業區田洋路一路 26 號

No.26, Tianyang 1 Rd Datianyang Ind.Zone,Dongfang District, Songgang Township,

Baoan Qu, Shenzhen, Guangdong Province, P.R.C

Tel:+86 755 27089201 Fax:+86 755 27089206

Tel :+886 4 26812368

Fax:+886 4 26816133

旭生自行車(越南)責任有限公司 SUNRISE BICYCLE (VN) CO.,LTD

平陽省夷安縣已安市社新東協坊新東協生產區

Công ty TNHH xe đạp Bình Minh Địa chỉ: khu sản xuất Tân Đông Hiệp,

phường Tân Đông Hiệp, thị xã Di An, tỉnh Bình Dương

Tel:+84 650 3775698 Fax: +84 650 3775699



# JIEN JIEN MEI



JM70S-17

TYPE: 700C

MATERIAL: Stainless steel



**JIEN JIEN MEI INDUSTRY CO., LTD.**

No.622, Shalun Rd., Fonglunvill., Pitou Hsiang, Changhua County, Taiwan

Tel: 886-4-8911288 Fax: 886-4-8911266 E-mail: jjm8911288@gmail.com

# PRODUCTS

專業產品

- (A) Thermostable Nylon Film Tube  
(also called: Air tube & Air bag)
  - (B) Rim wheel Air bag
  - (C) Different shapes of air bag
  - (D) OPP thin film, Shrink film, Distill bag
  - (E) Vacuum bag for composites forming
  - (F) J206-Efficient Release film tube
  - (G) J209 Latex Air bag
- (A) 耐高溫尼龍膜管(又稱:風管、氣袋)
- (B) 專利甜甜圈輪圈型(圓形)氣袋
- (C) 各類異型耐高溫氣袋  
(實例:把手、前後叉、上叉,等等)
- (D) OPP膜、收縮膜、蒸餾袋。
- (E) 真空袋(複合材料成型專用)。
- (F) J206免含浸高效離型風管  
(又稱為:風管,氣袋)
- (G) J209乳膠氣袋

# JINTEK CORPORATION

[GOLDAGES.DIYTRADE.COM](http://GOLDAGES.DIYTRADE.COM)



Website | GOLDAGES.DIYTRADE.COM

## High Quality, Good Price And Good Service

### 01 | 簡介 ABSTRACT

We've had experience in manufacturing nylon thin film/tube and shared the major market in composites using for thirty years. To level up our capability, We have factories in Taiwan and China now. We take the lead in quality, service, efficiency, customer specialization, RD ability and so on. We sell our products to our customers all over the world. We offer the best and affordable price to our customers as feedback. Besides, we never deceive our customers to get profit, so we have three promises as follows, First, 100% brand new materials (no recycled materials). Second, quantities of products will be the same as orders. Third, the thickness of products will be the same as orders. We make all our efforts sincerely to match our customers' need because we would like to have a long-term partnership with our customers. Based on quality and customer-friendly service, we hope that we can grow up and cooperate with you for a long time.



我們有數十載製造尼龍膜管之經驗,在碳纖維的領域中,持有大部份的市場,目前有台灣廠與中國廠,無論是:品質、服務、效率、專業設計、研發能力..等等,均領先於同業,目前有內外銷,其間承蒙知名複材業界的提攜與支持,我司總懷感恩之心,也盡量以平價的方式回饋給愛用者,並承諾3大保證:保證100%新料製造(絕不使用回收廢料),保證絕對不短少數量交貨,保證絕不偏薄厚度(若以重量計價者也不惡意增加厚度,絕不從中謀利),我司總以誠懇之心經營,我不希望與您僅僅是一次性的合作機會,期盼您將是我們長期一起努力的伙伴,在成長中,我司不斷虛心求教,堅持用品質當口碑,服務當基本,降低零不良率為目標,從萌芽至茁壯,始終如一,期盼與您合作,共同成長,共創佳績。

### 02 | 用途 APPLICATION

The Nylon thin film/tube is used mainly at forming or packing process of carbon fiber. It is indispensable materials for carbon fiber products, such as rackets, aeronautical materials, medical supplies, bicycles, baseball bats, fishing rods, golf poles, hockey poles, snow poles, automotive components, models of airplane, handset, windmill wing...etc..

應用範圍相當廣泛,一般較常用於碳纖維產品的成型或包裝上,是碳纖維產品不可或缺的好伙伴,例如:球拍,航太,醫材,自行車,冰曲,釣桿,高爾夫球桿,棒球棒,曲棍球,雪桿,模型飛機,汽車零件,筆電,手機,風車羽翼,登機箱,3D碳纖維產品...等等。



J209乳膠氣袋



J209 Latex Air bag



J206免含浸高效離型風管  
J206-Efficient Release film tube

總公司/台灣廠:金有達股份有限公司(金時代)

地址:32668台灣桃園市楊梅區梅獅路2段156巷15號1F  
Corporation & Taiwan factory :Jintek Corporation & Gold Ages CO.,LTD Address:1F.,  
No.15, Ln. 156, Sec. 2, Meishi Rd., Yangmei District, Taoyuan City 326, Taiwan  
TEL:+886-03-4826878 FAX:+886-03-4817676  
E-Mail:gold\_ages@yahoo.com.tw Website:http://goldages.diytrade.com

中國廠:東莞市全和塑膠製品有限公司

地址:廣東省東莞市塘廈鎮蓮湖村蓮湖西路7號巨嘉工業園廠房C棟101單元  
Chinese Factory: Quan He Co.,LTD  
Address:Unit 101, Building C, Cujia Industrial Park, no. 7 Lianhu W. Rd.,  
Lianhu Village, Tangxia Town, Dongguan City, Guangdong, China.  
TEL: +86-0769-82031598 FAX: +86-0769-82031599



**JS-381**  
 27.5" \* 490mm  
 Bosch System  
 IN-TUBE Battery  
 (Prototype)



**JS-382**  
 27.5" \* 410/440/490mm  
 Shock Length: 200mm  
 Travel: 140mm



**JE-381**  
 27.5" \* 420mm  
 Shimano E8000  
 IN-TUBE Battery



**JE-382**  
 27.5" \* 450mm  
 Bosch System  
 IN-TUBE Battery



**JE-383**  
 27.5" \* 420mm  
 Shimano E8000



**JR-881**  
 700C \* 520mm  
 FAZUA System  
 IN-TUBE Battery



# High quality frame you need.



**JA-381**  
27.5" \* 420mm



**JE-781**  
28" \* 480mm  
Bafang System



**JB-981**  
20" \* 430mm  
Shimano E6000



**JB-982**  
20" \* 400mm  
Bosch System



**JO-081**  
27.5" \* 480/400mm  
Bafang System

## We are your best choice.





**Lightwave Bikes International Inc.**

No.71, Ln. 32, Houbei Rd., Hemei Township,  
Changhua County 508, Taiwan  
TEL: +886-4-7362855 FAX: +886-4-7362857  
E-mail: info@lightwavebikes.com  
http://www.lightwavebikes.com



### PIONEER-P17M

TYPE: E-BIKE WITH SHIMANO SYSTEM  
TUBE TYPE: 3 IN 1 TUBING  
MATERIAL: ALLOY 6061  
FRAME SIZE: 26" 700C



PATENTED



### HYDRO-H03M

TYPE: FIXED GEAR  
TUBE TYPE: HYDROFORMING TUBING  
TRIPLE BUTTED TUBING  
MATERIAL: ALLOY 6061 / 7005  
FRAME SIZE: 700C



### BETWEEN-B14L

TYPE: CITY/COMFORT/E-BIKE  
TUBE TYPE: 2 IN 1 TUBING  
MATERIAL: FULL ALLOY 6061  
FRAME SIZE: 26", 700C  
INTERNAL CABLE ROUTING: OPTION



PATENTED



### PIONEER-P13L

TYPE: CITY/COMFORT/E-BIKE  
TUBE TYPE: 3 IN 1 TUBING  
MATERIAL: FULL ALLOY 6061  
FRAME SIZE: 26", 700C  
INTERNAL CABLE ROUTING: OPTION



PATENTED



### SUPPORT-S11L

TYPE: CITY/COMFORT/E-BIKE  
TUBE TYPE: 2 IN 1 TUBING  
MATERIAL: FULL ALLOY 6061  
FRAME SIZE: 26", 700C  
INTERNAL CABLE ROUTING: OPTION



PATENTED



### ETERNITY-E11L

TYPE: CITY/COMFORT/E-BIKE  
TUBE TYPE: 2 IN 1 TUBING  
MATERIAL: ALLOY 6061  
FRAME SIZE: 26", 700C  
INTERNAL CABLE ROUTING: OPTION



PATENTED



**Customized Design**



## FRAMES

### Model: LAL-275M-D64

Type: 27.5" MTB Suspension Frame 4 Bar Linkage Active Design  
Material: #6061  
H/T Size: 1-1/8" UPPER, 1-1/2"  
Rear Hub: 142mm\*12 E-Thru  
Frame Travel 139mm  
\*E-Bike Shimano E8000  
Available Size(C-T): 17"-21"



### Model: LAL-275M-D68

Type: 27.5" MTB Suspension Frame 4 Bar Linkage Active Design  
Material: #6061  
H/T Size: 1-1/8" UPPER, 1-1/2"  
Rear Hub: 142mm\*12 E-Thru  
Frame Travel 149mm  
\*E-Bike Bosch System  
Available Size(C-T): 16"-21"



### Model: LAL-275M-D65

Type: 27.5" MTB Frame  
Material: #6061  
H/T Size: 1-1/8" UPPER, 1-1/2"  
Rear Hub: 142mm\*12 E-Thru  
\*E-Bike Shimano E8000  
Available Size(C-T): 15"-21"



### Model: LAL-275M-D67

Type: 27.5" MTB Frame  
Material: #6061  
H/T Size: 1-1/8" UPPER, 1-1/2"  
Rear Hub: 142mm\*12 E-Thru  
\*E-Bike Bosch System  
Available Size(C-T): 15"-21"



### Model: LAL-28M-D66

Type: 28" Trekking  
Material: #6061  
\*E-Bike Shimano E6000



### Model: LAL-28M-D69

Type: 28" Trekking  
Material: #6061  
\*E-Bike Bosch System



### Model: Le1-700C-D70

Type: Lightest Racing Frame  
Material: #e1  
Tensile Strength: 450mpa  
Available Size(C-T): 440-600MM  
Raw Weight: 1.1kg (470MM)



### Model: Le1-700C-D71

Type: Lightest Racing Frame  
Material: #e1  
Tensile Strength: 450mpa  
H/T Size: 1-1/8" UPPER, 1-1/2"  
Available Size(C-T): 440-600MM  
Raw Weight: 1.24kg (530MM)



### Model: Le1-700C-D72

Type: Lightest Racing Frame  
Material: #e1  
Tensile Strength: 450mpa  
H/T Size: 1-1/8" UPPER, 1-1/2"  
Available Size(C-T): 440-600MM  
Raw Weight: 1.4kg (530MM)



### Model: Le1-275m-D73

Type: 27.5" MTB Frame  
Material: #e1  
Tensile Strength: 450mpa  
H/T Size: 1-1/8" UPPER, 1-1/2"  
Rear Hub: 142mm\*12 E-Thru  
Available Size(C-T): 15"-21"  
Raw Weight: 1.42kg (17")



### Model: LAL-700C-D74

Type: Lightest Racing Frame  
Material: #6061  
H/T Size: 1-1/8" UPPER, 1-1/4"  
Available Size(C-T): 460-600MM



#### TAIWAN FACTORY

No.3, Kung 10th Rd., Youth Industrial Zone, Tachia Town,  
Taichung Hsien 437, Taiwan  
Tel: 886-4-26814881-5 Fax: 886-4-26815211  
Executive: Tony Chiu  
E-mail: lungi001@ms5.hinet.net

#### CHINA FACTORY (DONGGUAN)

No.67 Tang Tian S.RD., Tongxia Town,  
Dong Guang City, China  
Tel: 86-769-87723781-2 Fax: 86-769-87723784  
E-mail: sales-dg@lung-i.com

#### CHINA FACTORY (TAICANG)

No.328 Zhenghe East Rd, Ludu Town,  
Taicang City, Jiangsu, China  
Tel: 86-512-53456388 Fax: 86-512-53456389  
E-mail: sales@tclungi.com ;  
sales1\_tc@lung-i.com



### MK-MTB-NO.12 / MTB

Carbon

26"\*16"/17.5/19"/20.5"/22"(c-t)

With post mount d/brake adaptor on C/S

More models of MTB frames available



### MK-M17 / 29ER

Carbon

29"\*16"/17.5/19"/20.5"/22"



### MK-ROAD NO.10 / ROAD

Carbon

700C\*48CM/50/52/54/56/58/60/62/64(c-t)

More models of Road frames available



### MK-ROAD NO.5 / ROAD

Carbon

700C\*48CM/50/52/54/56/58/60/62/64(c-t)

700C\*68CM/70/72/74/76/78/80/82/84(H)

Super light of high STW,With high module carbon



### MK-X3 / CROSS COUNTRY

Carbon

26"\*40CM/45/49/54(c-t)-regular s/post

26"\*60CM/65/69/74(c-t)-ISP tupe

Travel:105mm,more models with varied travels available



### MK-TT / TIME TRIAL/TRIATHLON

Carbon

700C\*52CM/53/54(c-t)

Matching seat post available

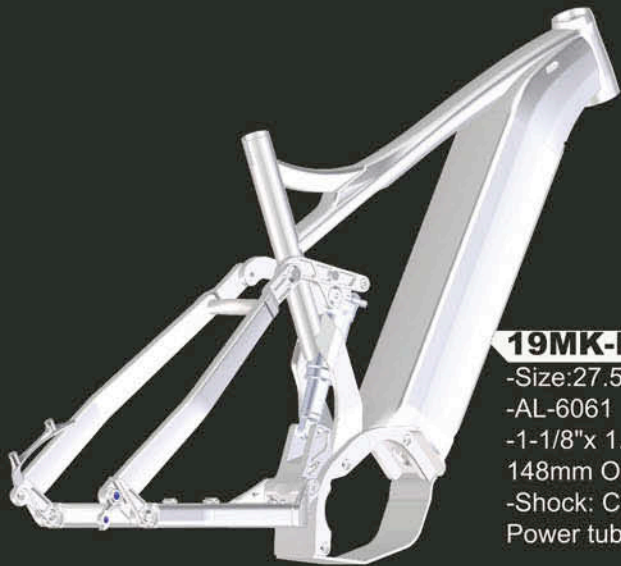

### 19MK-E15275B2

- Size:27.5" M/ L /XL
- AL-6061
- 1-1/8"x 1.5"taper head-tube/  
148mm OLD rear Wheel.
- Shock: CC-200 x Travel:153mm
- Power tube by BOSCH



### 19MK-E13275S1

- Size:27.5" S/ M/ L
- AL-6061
- 1-1/8"x 1.5"taper head-tube/  
148mm OLD rear Wheel.
- Shock: CC-190 x Travel:134mm
- Power tube by SHIMANO



### 19MK-EHT29B1

- Size:29" x 46-52CM
- AL-6061
- 1-1/8"x 1.5"taper head-tube
- For 29"\*2.25" tire design
- Power tube by BOSCH



### 19MK-E16275S3

- Size:27.5" M/ L /XL
- AL-6061
- 1-1/8"x 1.5"taper head-tube/  
148mm OLD rear Wheel.
- Shock: CC-210 x Travel:157mm
- Power tube by SHIMANO



### 19MK-RD12

- 700C x 47-61 cm
- AL-6066 Super lite
- 1-1/8" x 1-3/8"taper head-tube  
/130mm OLD rear Wheel.
- BB-86mm



### 19MK-EROADF1

- 700C x 54-62 cm
- AL-6061
- 1-1/8" x 1.5"taper head-tube  
135mm OLD rear Wheel.
- Power tube by FAZUA



B01



# LUNG YANG

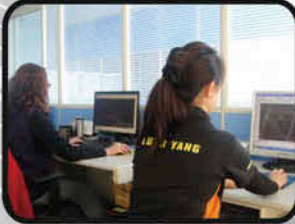

Professional Design Development



EN Test Machine



Product Liability Insurance

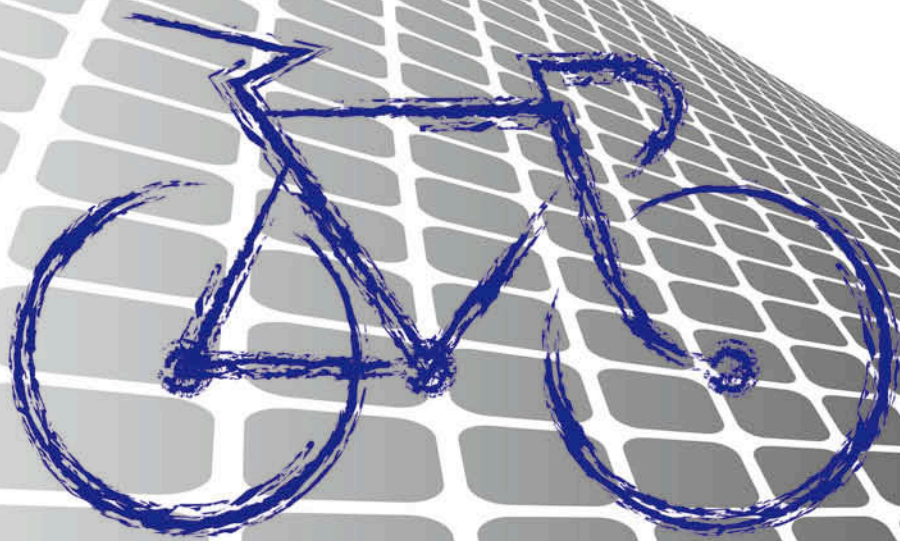

## 龍易有限公司

地址:台中市大甲區東西六路一段216號  
TEL:(04)26874185 FAX:(04)26889439  
E-mail:ly874185@ms24.hinet.net

## LUNG YANGS CO.,LTD

NO.216 SEC. 1 DONGXI 6th RD.  
TACHIA DIST. TAICHUNG CITY TAIWAN  
TEL:+886-4-26874185 FAX:+886-4-26889439  
E-mail:ly874185@ms24.hinet.net

[www.lung-yang.com](http://www.lung-yang.com)





# MaxWay

WWW.MAXWAY.COM.TW



## MAXWAY CYCLES CO., LTD

139-3 Dong Ming Road, Dajia Dist. Taichung City 43773, Taiwan

TEL:886-4-26815668

FAX:886-4-26816448

Email:maxway@mail.maxway.com.tw



**Y16T01**

▲ MATERIAL: STAINLESS  
TYPE: 700C TOURING FRAME



**Y15R01**

◀ MATERIAL: 4130 CR-MO  
TYPE: 700C LUGGED RACING FRAME



**Y13M01**

▲ MATERIAL: 4130 CR-MO  
TYPE: 650B PINION GEARBOX FRAME



**Y16M02**

◀ MATERIAL: STAINLESS  
TYPE: 27.5+ MTB E-BIKE FRAME



**Y17T01**

◀ MATERIAL: 4130 CR-MO  
TYPE: 700C TOURING FRAME

Manufacturer In Taiwan

# TITANIUM FRAME

---



BOSCH GEN2



鈦郁工業股份有限公司  
ORA ENGINEERING CO., LTD



oraeng@oraeng.com.tw  
Tel: +886-4-25586915  
Fax: +886-4-25586958

台中市后里區聯合里三重二路288號  
No.288, Sanchong 2nd Rd., Houli Dist.,  
Taichung City 421, Taiwan



- Teen Bike
- Belt Drive System
- AL 6061 Frame
- Customization Crank Length



## Being able to draw / design your frame



### Belt Drive System



**Free wheel**  
24T ,28T

for SHIMANO internal geared hub / KT single speed

**Chain wheel**  
44T ,46T ,48T

### Spacer

*For Single Speed Chain Wheel*



1mm ,2mm ,2.5mm ,10mm ,20mm



# TITANIUM ROAD

Material: Ti-6Al-4V+Ti-3Al-2.5V  
Head Tube: 1-1/8 \* 1-1/2  
Seatpost: Ø31.6  
Bottom Bracket: Press Fit PF30  
Finish: mill finish/high polish/sand blasting



# TITANIUM FORK

Material: Ti-6Al-4V+Ti-3Al-2.5V  
Integrated O.D.: 1-1/2  
Steer: 1-1/8 (700C)  
Offset: 43-50mm  
Finish: mill finish/high polish/sand blasting



MARS



TJ 世紀



TJM-E8001



TJR-PM001



TJR-TCR 700C



TJR-003 700C LUG



TJM-B1001



TJM-FAT 26"



TJR-F3T



TJM-KS003T



TJM-003



TJC-4M001 Mixte



TN-E8



TN-FM005



TNP001

(No need to use inner catheter)

TON JIN TECHNOLOGY CO., LTD

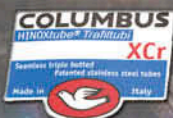

# Twin-Frame Bicycle Patents on Sale : Total US\$ 800,000

Market and Price	Title (名称)	Filed	Period (专利期限)	Process and Certificate
<b>European Union</b> US\$ 400,000	Twin-Frame Bicycle Patent Application: 11 161 941.7	2011.4.11	2018.2.21~2028.6.9 Bulletin 18/08 of 2018.2.21	Patent No. 2394896 Priority claimed : 2010.6.11/USA 814203
<b>U.S.A.</b> US\$ 400,000	Dual Riding and Driving Tricycle	2009.7.23	2011.1.25~2028.6.9	No.12/507,914 US\$7,874,566 B1
	Twin-Frame Bicycle	2010.6.11	2012.4.3~2028.6.9	No.12/814,203 US\$8,146,937 B2
<b>P.R.O.C.</b> US\$ 250,000	并列式脚踏车	2009.3.24	2013.2.6~2029.3.23	CN102036873A 发明第 1132402 号
	双车架脚踏车	2011.4.15	2013.5.1~2031.4.14	CN102275622B 发明第 1188273 号
<b>Taiwan</b>	并联式脚踏车	2009.6.30	2012.6.21~2029.6.29	No.201004835 发明第 I366533 号

## Bicycle and Bicycle

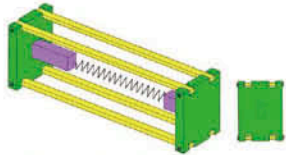

One articulation mechanism is disposed between a primary bicycle body and an auxiliary bicycle body, wherein the mechanism serves in synergy an parallelogram and a spring counteracts the deformation of the mechanism to maintain equilibrium. Both ends of the mechanism will be fixed on the bicycle bodies with two screws, the spring tension will be adjusted with another screw. Therefore, when bicycles turn or move on uneven surface, it can still keep moving stably, but will not overturn.



Both the primary bicycle and the auxiliary bicycle are ordinary bicycles. The juxtaposing link contains a turning bar, an articulation mechanism and a connecting rod.

If the auxiliary bicycle is rode by an adult, a supplementary handlebar can be installed on the connecting rod. It can be provided for child, the elder or the handicap to ride.



## Bicycle and Sidecar

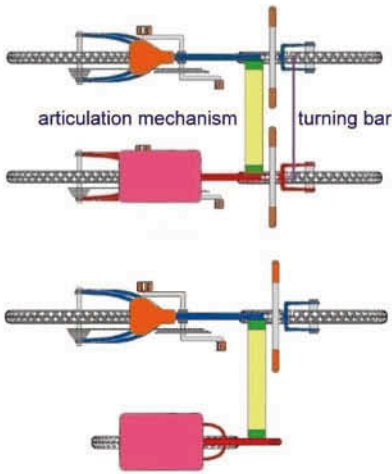

It is convenient and comfortable for riders to carry their child or pets out to go for a bike ride. Young children are physically unable to

pedal the bicycle. Likewise, pets have no ability to step on the pedal of a bicycle, so it is economic and convenient for select a unicycle or, alternative, unicycle driven by motor.

make choices according to their needs. If a child is seated, a dinner plate can be installed on the connecting rod that is between the mechanism and the bicycle body.

The primary bicycle is responsible for the safe operation of the vehicle. The design of this model allows the user to



## Dual Riding and Driving Tricycle

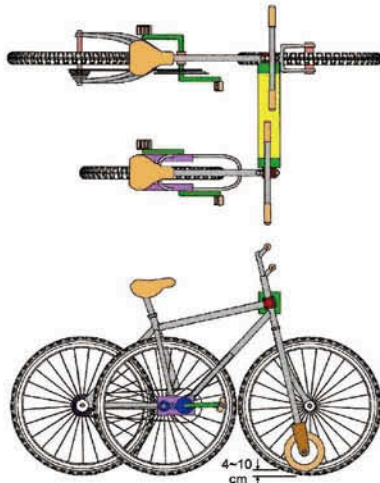

1 lock  
2 adjust  
3 loose  
tricycle mode

1 loose  
2 adjust  
3 lock  
bicycle mode

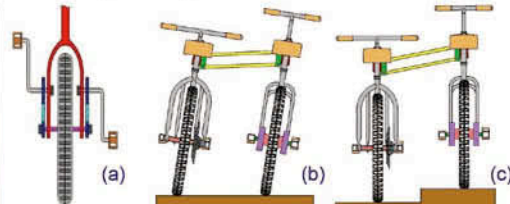

(a) pedals drive wheel through gear unit  
(b) turning right  
(c) uneven ground



## VS-ENDURO-E8000

Frame Type: Hardtail E-Bike

Frame Material: AL6061  
Weight: 2.32KGS  
SIZE: 406/457/508mm



## E-8020 SUSPENSION

Frame Type: Suspension E-BIKE

Frame Material: AL6061  
SIZE: 457mm  
Travel: 160mm



## VS-ENDURO-650B

Frame Type: ENDURO  
Frame Material: AL7005  
Weight: 2.94KGS  
SIZE: 406/450/508mm  
Travel: 150/160mm  
Linkage system :  
4 Bar Linkage



## E-7000 SUSPENSION

Frame Type: Enduro suspension E-bike  
Frame Material: AL6061

SIZE: 460mm  
Travel: 160mm



## VS-MTB-3

Frame Type: MTB  
Frame Material: Reynolds 853  
Weight: 2.11KGS  
SIZE: 29" (C-T 19")



## VS-ROAD-CR-LUG1

Frame Type: ROAD  
Frame Material: CR-MO  
Weight: 1.91KGS  
SIZE: 480/510/540/  
560/580/600mm





**MOSSO**  
www.mosso.com.tw

**MIZZI**  
Mossa complete bike Brand

**TAIWAN Headquarters**  
**WWEI FONG MACHINERY WORKS.CO.,LTD.**  
Address:NO.239,Sec. 1,Dongxi 7th Rd.,  
Dajia Dist., Taichung City 437 , Taiwan  
Tel:886-4-2688-3118  
FAX:886-4-2688-3928  
Dealer E-mail:mosso@ms21.hinet.net  
Customer service E-mail:info@mosso.com.tw

**CHINA Factory**  
**FOSHAN FONGDA TECHNOLOGY Co., Ltd.**  
Address:Workshop B,Pingtang Industrial Zone,Guanyao,  
Shishan Town, Nanhai District, Foshan City,  
Guangdong Province, .  
Tel:86-8586-2698  
FAX:86-8586-2595  
Dealer E-mail:mosso@ms21.hinet.net  
Customer service E-mail:info@mosso.com.tw



**MOSSO**  
www.mosso.com.tw

**FALCON CB**

Type	650B MTB
Material	T700 Full Carbon
Size	15.5"-17"
Weight	1230g/17"



**992 PRO**

Type	29ER MTB
Material	Aluminium 7046
Size	15.5"-17"
Weight	1280g/17"



**7591 PRO**

Type	650B MTB
Material	Aluminium 7046
Size	15.5"-17"
Weight	1280g/17"



**ELECTRIC-URBAN BIKE**

- ▲ Invisible Patented Battery
- ▲ Aluminium 7005
- ▲ 250W .36V .5200mAh
- ▲ Light weight 12.5KG
- ▲ 25km/hr. 50-60KM distance



**790PRO**

Type	700C
Material	Alu 7046
Size	47 / 50 / 53 CM
Weight	1050g

**971TI-DB3**

Type	Road Frame 700C
Material	3AL/2.5V Titanium
Size	46cm - 56cm
Weight	1.28Kg / 48cm
Seat Dia	27.2mm

■ Double Butted Tubes, Lower LOGO



**ROAD**

**MADE IN TAIWAN**

**HANDMADE WHEELS**



**MOSSO VELOCE VT70** WEIGHT: FRONT 690G / REAR 850G

**MOSSO RC60** WEIGHT: FRONT 710G / REAR 890G

TYRE TYPE	Clincher	BRAKING SYSTEM	Caliper
TYRE SIZE	700C	FRONT AXLE COMPATIBILITY	QR .
WEIGHT	1540 g.	REAR AXLE COMPATIBILITY	QR .
RIM MATERIAL	ALUMMINUM 6066	FRONT WHEEL SPOKES	20 (10 left + 10 right)
RIM HEIGHT	Front and rear: 30 mm	REAR WHEEL SPOKES	24 (12 left + 12 right)
RIM WIDTH	22 mm. ETRTO 18C	SPOKES MATERIAL	Stainless steel, double butted
TYRE WIDTH	From 23 mm to 25 mm	SPOKES PROFILE TECHNOLOGY	Aero, straight pull

TYRE TYPE	Clincher	BRAKING SYSTEM	Caliper
TYRE SIZE	700C	FRONT AXLE COMPATIBILITY	QR .
WEIGHT	1600 g.	REAR AXLE COMPATIBILITY	QR .
RIM MATERIAL	Carbon	FRONT WHEEL SPOKES	20 (10 left + 10 right)
RIM HEIGHT	Front and rear: 38 mm	REAR WHEEL SPOKES	24 (12 left + 12 right)
RIM WIDTH	ETRTO 17C	SPOKES MATERIAL	Stainless steel, double butted
TYRE WIDTH	From 23 mm to 25 mm	SPOKES PROFILE TECHNOLOGY	Aero, straight pull

**FK-M5**

Rigid Fork



Color : white/blue;white/red;Black/green  
Black/Yello,Black/red,Black/blue,  
Black/Gold SIZE : 28.6\*25.4\*260mm  
Material : Alu 7005 Weight : 0.8kg



**FK-M3**

Color : White , Black  
Material : Alu 7005  
SIZE : 28.6\*25.4\*260mm  
Weight : 0.7kg



**FK700-D2**

Color : White/red ,  
Black/purple White/Blue  
Material : Alu 7005  
SIZE : 28.6\*260mm  
Weight : 550g



**SEAT POST**

**AL-SP-06CB**  
Color : black , green / red / blue  
handlebar : 260g  $\phi$ 31.6 x 380mm  
/400mm  
Material : Alu6061+Wrap 3K Carbon







**WFL20-02**

TYPE: Flat Land  
MATERIAL: AL6061/AL7005



**WFS20-10**

TYPE: Free Style  
MATERIAL: Full CR-MO



**WFS20-14**

TYPE: Free Style  
MATERIAL: Full CR-MO



**WFS20-05**

TYPE: Free Style  
MATERIAL: Full CR-MO



**WMB26-01**

TYPE: 26" or 29" MTB  
MATERIAL: Full CR-MO



**WDH26-08**

TYPE: Down Hill 26"  
MATERIAL: Full CR-MO



**WFX70-07**

TYPE: 700C or 26" Fixed Gear  
MATERIAL: Full CR-MO



**WFX70-06**

TYPE: 700C or 26" Fixed Gear  
MATERIAL: Full CR-MO



## CLASSIC CYCLEWORKS

Racing. Trekking. Cross. Street. ATB

TEL: +886-4-8610226

FAX: +886-4-8612321

email: jun.kai888@msa.hinet.net

彰化縣溪湖鎮媽厝里湳底路85-58號

No.85-58, Nandi Rd., Xihu Town,

Changhua County 51447, Taiwan



## Yh Lug Frame

銅焊精品鋼管車

亞恆科技有限公司  
YA-HENG TECHNOLOGY CO., LTD.



■ J-2359

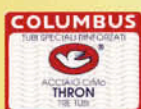



### 永富車料股份有限公司

NO.576, Sec. 4 Chang Shui RD.,  
Pyi-Tou Shiang Chang-Hua Hsion,  
Taiwan.

Taiwan  
TEL:+886-4-8926337-9  
FAX:+886-4-8922429  
E-mail: yf1210@mts46.hinet.net

### 元富機械(深圳)有限公司

Build A&B, NO.2, Sai'er Kang Road,  
Fu-Rong Industrial Area Shajing Town,  
Bao'an-County, Shenzhen, China

China  
TEL:755-2725-3239 / 755-2725-3031-2  
FAX:755-2725-3537 / 755-2715-3279  
E-mail: yuanfuh@21cn.net



#### WIM2601M140522

Frame Type: MTB Suspension XC

Size: 27"x41CM

Head Tube: 1 1/8-1.5

Shock Travel: 40mm

Frame Travel: 125mm

Main Pivot: Bearing system

Drawing Code: WIM2601M140522



#### WIM2710M140621

Frame Type: MTB Suspension XC

Size: 27"x41CM

Head Tube: 1 1/8-1.5

Shock Travel: 40mm

Frame Travel: 110mm

Main Pivot: Bearing system

Drawing Code: WIM2710M140621



#### YOQ6502M140552

Frame Type: MTB Suspension XC

Size: 27"x43CM

Head Tube: 1 1/8-1.5

Shock Travel: 38mm

Frame Travel: 100mm

Main Pivot: Bearing system

Drawing Code: YOQ6502M140552



#### YFH2622M131275

Frame Type: MTB Suspension XC  
 Size: 27"x41CM  
 Head Tube: 1 1/8-1.5  
 Shock Travel: 40mm  
 Frame Travel: 105mm  
 Main Pivot: Bearing system  
 Drawing Code: YFH2622M131275



#### YFH2707M121194

Frame Type: E-Bike  
 Size: 27.5"x52CM  
 Head Tube: 1 1/8  
 Transmission: Shimano system  
 Battery Location: D/T  
 Dropout: Post Mount Dropout  
 Drawing Code: YFH2707M121194



#### YFH2801M140454

Frame Type: E-Bike (internal Cable)  
 Size: 28"x48CM  
 Head Tube: 1 1/8 – 1.5  
 Transmission: Shimano system  
 Battery Location: Carrier  
 Dropout: Post Mount Dropout  
 Drawing Code: YFH2801M140454

### 700C Road Disc



Model : YMLZ-GXP-FM  
Material : Columbus Life  
Size : By order

Disc : Flat Mount  
Weight: 2 kg(52cm)

### 650B MTB Hardtail



Model : YMS3 650B  
Material : Satin 301 Stainless  
Size : By order

BB : PF30  
Weight : 2.43kg(17")  
Available in Boost 148

### E-MTB Hardtail Integrated



Model : YMM6-E8-INT  
Material : 6061 Hydroforming  
Size : By order

Motor : Shimano  
Weight : 4.31kg(48cm)

### Pinion Gearbox



Model : SPR8-P  
Material : Cr-Mo  
Dropout : hotizontal

Gear : Pinion  
Size : By order



# yoan

YOAN TECHNOLOGIES CO., LTD

T +886-4-26802607 F +886-4-26802608

OEM/ODM Frame Manufacturer No.221, Da'angang Rd., Dajia Dist., Taichung City, Taiwan E yoan0124@ms76.hinet.net W www.yoan.com.tw

# Classic Gent

The most traditional and classic frame type in bike history. Opa frame is using parts which were all designed for tough and to be a gorgeous classic frame. OLY experienced RD and producing can provide you right taste of the fashion looking vintage bike frame and fork.



## Reliable Material Source



## Complete Mold Room

A complete mold room which are able to build almost all kinds of production tooling, save cost and shorten time for opening mold.



## Welding Quality Requirement      Various surface choices



## Steel / Cr-Mo Frame & Fork and Alloy Parts in the same factory



## CONTACT INFORMATION

ADD : Lot c5, Road N4 & D2 Nam Tan  
Uyen Industrial Park, Khanh Binh Ward  
Tan Uyen, Binh Duong Province, Viet Nam  
TEL : 84 274-3782085  
FAX : 84 274-3782088  
Email : info@olympicpro.com

**OLYMPICPRO** Manufacturing Co., was established in 2002. The main products are bike frames, forks(Steel/Cr-Mo), and forging parts(Alloy). In January 2011, Olympic Pro moved to the new factory, located in Nam Tan Uyen Industrial Park, Binh Duong Province. Current Customers are from around the world and also local market.

Olympic Pro would like to provide customers a full service who needs steel /Cr-Mo frame and fork, especially the ones need the traditional type and something new idea of bicycle frame sets.

Olympic Pro is a factory which has both ability of steel frame & fork and alloy forging parts producing. As a member of Vietnam supplier chain, we also provide all kinds of machinery process service.





# **ANSHENG**

Ansheng Precision Metal Products Co., Ltd.



28" E-Bike  
Bosch System  
Integrated Battery  
**ASZ18002**



27.5" & 29"  
Brose System  
BMZ V7 Battery  
**ASZ18001**



27.5" & 29" E-Bike  
Shimano E8000  
E8010 Battery  
**ASZ18004**



28" E-Bike  
Yamaha System

**ASZ18003**



Wave 28" City  
Bosch System  
Carrier Battery  
**ASZ18006**



Wave 28" City  
Bosch System  
Carrier Battery

**ASZ18005**

太仓安笙精密金属制品有限公司

Ansheng Precision Metal Products Co., Ltd.

Address: No.33, Jiang Nan Road, Ludu Town, Taicang City, Jiangsu Province, China

Tel: 0512-82781588 Fax: 0512-82781581

E-mail: ka6969@126.com, karensjh@126.com

久東實業股份有限公司(台灣)

KARSTEN CYCLE INDUSTRIAL Co., Ltd.

Address: No.60, Wu Chia N. Rd, Yung An Tusn, Da'an Dist, Taichung City, Taiwan

Tel: 04-26865665 Fax: 04-26877098

E-mail: karsteng@ms41.hinet.net



27.5" & 29" Suspen.  
Shimano E8000  
E8010 Battery

ASZ18008



27.5" & 29" Suspen.  
Borse System  
BMZ V7 Bsttery

ASZ18007



20" Folding E-Bike  
Bosch System

ASZ18009



20" Folding E-Bike  
Integrated Battery

ASZ18010



27.5" & 29" E-Bike  
Shimano E8000  
E8010 Battery

ASZ18011





**嵩雋車業有限公司**  
**SONG ZUN IND., LTD**

彰化縣溪湖鎮西勢里興安路30巷46號  
NO.46 LANE 30,HSING ANRD.,HSIHU TOWN.  
CHANGHUA COUNTY.TAIWAN  
TEL:886-4-8852014 FAX:886-4-8821693  
<http://songzun.com.tw>  
Mail:song.zun@msa.hinet.net

**SZ-BF1301**

Type:29" Belt Drive Frame  
Material:4130 Cr-mo Triple Butted Tubing



**SZ-RT1607**

Type:650B Road Bike Frame  
Material:4130 Cr-mo Triple Butted Tubing



**SZ-RT1602**

Type:700C Road Bike Frame  
Material:4130 Cr-mo Triple Butted Tubing



**SZ-FI1705 .SZ-FI1703**

Type:26" Belt Drive Frame  
Material:4130 Cr-mo Triple Butted Tubing



**SZ-RT1604**

Type:700C Road Bike Frame  
Material:4130 Cr-mo Triple Butted Tubing



### SZ-RT1701

Type:20" lug Frame

Material:4130 Cr-mo Triple Butted Tubing



### SZ-FL1701

Type:20" lug Racing Fork

Material:4130 Cr-mo Double Butted Tubing

Headset:1"



### SZ-FT1602(KA602)

Type:700C Tig Racing Fork

Material:4130 Cr-mo Double Butted Tubing

Headset:1 1/8"



### SZ-FTA221(KA221)

Type:700C Alloy Racing Fork  
Material:AL-6061 Alloy Double Butted Tubing  
Headset:1 1/8"



### SZ-FTA501(KA501)

Type:700C Alloy Racing Fork  
Material:AL-6061 Alloy Double Butted Tubing  
Headset:1 1/8"



### SZ-FTA581(KA581)

Type:700C Alloy Racing Fork  
Material:AL-6061 Alloy Double Butted Tubing  
Headset:1 1/8"



### SZ-FT1601(KA601)

Type:650(700C) Tig Racing Fork  
Material:4130 Cr-mo Double Butted Tubing  
Headset:1 1/8"





品琦車料(深圳)有限公司

PING CHI BICYCLE PARTS ( SHENZHEN ) CO., LTD.

Shangxiawei 2nd Ind. Zone, Shasan Village, Shajing Town,  
Baoan District, Shenzhen, Guangdong, China.

Tel: +86 755 27269193 Fax: +86 755 27269613

E-mail: [chou@pingchibikes.com](mailto:chou@pingchibikes.com) Website: [www.pingchibikes.com](http://www.pingchibikes.com)



**10PC001**

1" FULL CR-MO, OVAL-BEND BLADES  
BRAZING W/INVESTMENT-CASTING  
CROWN & DROPOUTS



**17PC002**

1-1/8" FULL CR-MO, OVAL-BEND  
BLADES  
FORGED DROPOUTS W/IS DISC  
MOUNT



**10PC013**

1" FULL CR-MO, AERO-STRAIGHT  
BLADES W/FORGED DROPOUTS



**15PC024**

1-1/8" FULL CR-MO, INTEGRATED  
CROWN, OVAL-STRAIGHT BLADES  
FORGED DROPOUTS W/POST DISC  
MOUNT



**13PC001**

1-1/8" INTEGRATED CROWN  
ALLOY 6 SERIES AERO-STRAIGHT  
BLADES, FORGED DROPOUTS



**18PC001**

1-1/8" FULL ALLOY, AERO-STRAIGHT  
BLADES/FORGED DROPOUTS W/FLAT  
DISC MOUNT



**17PC003**

1-1/8" INTEGRATED CROWN  
ALLOY 6 SERIES AERO-STRAIGHT  
BLADES  
FORGED DROPOUTS W/IS DISC  
MOUNT



**17PC004**

ALUMINUM ALLOY FORK FOR E-BIKE  
1-1/8" TAPERED FOR 1.5 STEM,  
HYDRO-FORMING BLADES  
15MM THROUGH AXLE W/POST DISC  
MOUNT



品琦運動器材(漳州)有限公司

PINGCHI SPORTING DEVICE (ZHANGZHOU) CO., LTD.

NO. 170, Kengzaipu, Ganlin Village, Jiuzhen Town, Zhangpu county, Zhangzhou, Fujian, China.

Tel: +86 596 3921791 Fax: +86 596 3921790

E-mail: [chou@pingchibikes.com](mailto:chou@pingchibikes.com) Website: [www.pingchibikes.com](http://www.pingchibikes.com)



**17PQ003L28520**

RACING FRAME  
FULL CR-MO, TRIPLE-BUTTED, W/  
HYDRO-FORMED DOWN TUBE



**17PQ005M26520**

E-BIKE FRAME FOR BOSCH SYSTEM  
FULL CR-MO, BRAZING W/  
INVESTMENT LUGS & DROPOUTS



**17PQ007L28560**

MIXTE COMMUTER FRAME  
Full CR-MO, BRAZING ALL  
INVESTMENT-CASTING LUGS &  
DROPOUTS



**18PQ001L26500**

E-BIKE LADY FRAME FOR SHIMANO E-6000  
SYSTEM FULL HI-TEN, INTERNAL CABLE  
ROUTING ON SEAT TUBE

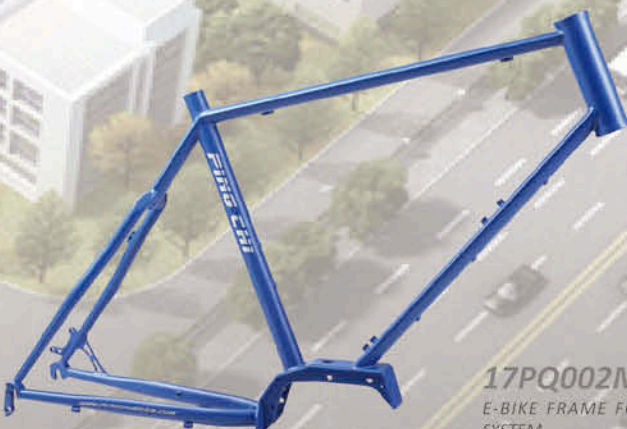

**17PQ002M26520**

E-BIKE FRAME FOR SHIMANO  
SYSTEM  
CR-MO/HI-TEN, TIG WELDING W/  
INVESTMENT-CASTING DROPOUTS  
& DISC MOUNT



**18PQ001M26520**

E-BIKE MEN FRAME FOR SHIMANO E-6000  
SYSTEM FULL HI-TEN, TIG WELDING  
WITH PRESSED DROPOUTS



ALLOY FORK 26"/27.5" 26"/27.5"/29"

CARBON FORK 29"/27.5" 27.5"/29"



INCLUDING CLAMP HEAD SET SEAT POST

27.5"/29" ALLOY AL6061

BIG/MIND SHARK 15"/17"



ALLOY BAR 31.6MM\*800L/780L

ALLOY STEM 31.6MM\*90L/100L

ALLOY SEAT POST 31.6MM\*350L/400L



INCLUDING FORK

700C CARBON

VATIOS 490/520/540MM



OPTIONS : SEAT POST



INCLUDING FORK HEAD SET SEAT POST

FIXED GEAR 700C AL6061

ELITE 500/520/540/560MM



INCLUDING FORK HEAD SET SEAT POST CLAMP

700C AL6061

WINDSTAR 480/500/520/540/560MM



29" CARBON

GRAVEL 16"/17.5"/19"



OPTIONS : SEAT POST  
 NEW REAR 12\*148MM



26" ALLOY AL6061

ARES 15"/17"/19"



OPTIONS : SEAT POST



INCLUDING FORK HEAD SET SEAT POST CLAMP

27.5"/29" ALLOY AL6061

PRORACE CAMO 15"/17"/19"



HEAD PARTS



PEDAL



HUB

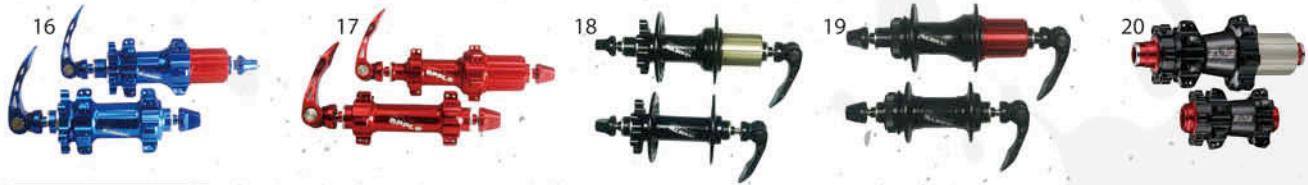

B.B



GLOVES



HELMET



BAG



GRIP





RACING 920

920

**VIKING**X

RACING 920

 VIKINGX SPORT



**VIKINGX**

 VIKINGX SPORT



## HANDLEBAR



**LB18HB01**  
ALLOY 6061  
WIDTH: 680-880MM



**LB24179**  
CARBON FIBER MTB RISE BAR  
WIDTH: 660-800MM



**LB24173**  
CARBON FIBER ROAD BAR  
WIDTH: 380-440MM



**LB24177**  
ALLOY ROAD FLAT DROP HANDLE BAR  
WIDTH: 380/400/420/440MM

## STEM



**LB18ST02**  
ALLOY  
EXT: 50MM  
BARBORE: 22.2MM



**LB18ST01**  
ALLOY 6061  
+ 3D FORGED  
EXT: 80/90/100/  
110/120MM  
BARBORE:  
31.8MM



**LB25171**  
CARBON FIBER  
EXT.: 80-130MM

## BELL



**LB18BL05**  
Brass Bell  
For Handlebar  
22-25.4mm



**LB18BL04**  
Brass Bell  
For Handlebar  
19.2-31.8mm



**LB18BL01**  
Electronic Horns  
For Handlebar  
22-31.8mm

## CO2 INFLATOR



**LB18TL01**  
ALLOY

## SEAT POST



**LB18SP01**  
ALLOY 6061+  
3D FORGED  
DIA: 31.6MM  
LENGTH:  
300-380MM



**LB18SP02**  
ALLOY 6061 +  
3D FORGED  
DIA:  
27.2/30.9/31.6MM  
LENGTH: 350MM



**LB13171**  
CARBON FIBER  
DIA.  
27.2/30.9/31.6MM  
LENGTH:  
300/350/400MM  
WEIGHT:200G

## CLAMP



**LB18SC01**  
ALLOY 6061  
DIA:  
31.8/34.9MM



**LB18SC01**  
ALLOY 6061  
DIA:  
31.8/34.9MM

## GRIP



**LB18GP012**  
SUPER LIGHT  
FOAM MATERIAL  
SIZE:22X130MM  
LOCKING RINGS



**LB18GP02**  
TPR  
22X128MM  
CLOSED END



**LB18GP03**  
ALLOY  
CLOSED FACE  
LOCKING RING

## CRANK+CHAINRING



**LB18CR01**  
34T 7075 ALLOY  
CRANK 6061 ALLOY  
1X11S



**LB18CR03**  
24/32 STEEL  
42T ALLOY  
CRANK 6061 ALLOY  
3X10S



**LB18CR04**  
22/30/40T STEEL  
CRANK 6061 ALLOY  
3X10S

## BAG



**LB18BG01**  
SADDLE BAG



**LB18BG03**  
SADDLE BAG



**LB18BG02**  
SADDLE BAG



**LB18BG04**  
TOP TUBE BAG

## TOOL KIT



**LB18TL02**  
13 IN 1 FLAT TOOL



**LB18TL03**  
19 IN 1 FLAT TOOL

## PEDAL



**LB18PD01**  
For MTB  
Aluminum CNC machined  
3 bearing system  
92x98x21mm



**LB18PD02**  
For MTB  
Aluminum CNC machined  
3 bearing system  
101x105x21mm



**LB18PD03**  
For MTB  
Aluminum CNC machined  
3 bearing system  
99x98x21mm



**LB18PD04**  
For MTB  
Aluminum CNC machined  
3 bearing system  
96x105x23mm



**LB18PD05**  
For MTB  
Aluminum CNC machined  
3 bearing system  
92x98x21mm



**LB18PD06**  
For MTB  
Aluminum CNC machined  
3 bearing system  
96x105.5x19.7mm



**LB18PD07**  
For MTB  
Aluminum CNC machined  
3 bearing system  
102x107x20mm



**LB18PD18**  
For MTB  
Die-cast aluminum with  
kraton inlaid  
LSL Bushing and Sealed Bearing  
109x89mm

## BOTTLE CAGE



**LB18CG01**  
500-750CC  
PLASTIC BOTTLE CAGE



**LB18CG02**  
500-750CC  
PLASTIC BOTTLE CAGE

**LB18HM01**



IN-MOLD, MATERIAL:EPS+PC SHELL  
VENTS:22+ VISOR:NO  
SIZE: M/L(57-61)  
WEIGHT: 250g

**LB18HM02**



IN-MOLD,  
MATERIAL:EPS+PC SHELL  
VENTS:15+VISOR:YES  
SIZE:M/L(57-61)  
WEIGHT:315g

**LB18HM04**



IN-MOULD, PC SHELL .  
BLACK AMERICAN EPS, NYLON STRAP,  
BUCKLE, RING FIT SYSTEM  
VENTS:24+WEIGHT:250g  
SIZE:M/L 54-61

**LB18HM05**



IN-MOD, PC SHELL+BLACK EPS  
INCLUDING VISOR (GLASSES)  
SIZE:L

**LB18HM06**



IN-MOD, PC SHELL+BLACK EPS  
BACK SIDE WITH  
EMBEDDED LED LIGHT  
SIZE:M

**LB18HM07**



24VENTS  
IN-MOD /PC+EPS  
SIZE:54-61CM

**LB18HM08**



18VENTS / IN-MOD  
PC+EPS  
W/VISOR  
SIZE:58-62CM

**LB18HM09**



16VENTS / IN-MOD  
W/LENS  
260g L :58-61CM

**LB18HM10**



20VENT / IN-MOD  
W/LED  
268G L :58-61CM

**LB18SD01**



SIZE: 270X135MM  
WEIGHT: 300g

**LB18SD02**



SIZE: 270X145MM  
WEIGHT: 340g

**LB18SD03**



SIZE: 273X125MM  
WEIGHT: 270g

**LB18SD04**



SIZE: 275X140MM  
WEIGHT: 295g

**LB441709**



SIZE: 280X140MM  
WEIGHT: 250g

**LB441710**



SIZE: 280X140MM  
WEIGHT: 301g



Tel : +886-4-2262-3598

E-mail : boblin@apexcreative.com.tw

**APEX CREATIVE**

[www.apexcreative.com.tw](http://www.apexcreative.com.tw)



● **AF7 - 201**

- ◆ AL6061
- ◆ 27.5 / 142x12mm E-thru
- ◆ 160mm Rear travel
- ◆ Shimano E-8000



● **AF7 - 207**

- ◆ AL6061
- ◆ 27.5 / 142x12mm E-thru
- ◆ 140mm Rear travel
- ◆ 4BAR - Enduro



● **AF7 - 209**

- ◆ AL6061
- ◆ 27.5 / 142x12mm E-thru
- ◆ 160mm Rear travel
- ◆ VPP - AM



● **AF7 - 213**

- ◆ AL6061
- ◆ 27.5 / 142x12mm E-thru
- ◆ 160mm Rear travel
- ◆ 4BAR - AM



● **AF7 - 210**

- ◆ AL6061
- ◆ 29ER / 142x12mm E-thru
- ◆ 120mm Rear travel
- ◆ 4BAR - XC



● **CF7 - 213**

- ◆ Carbon UD
- ◆ 27.5 / 148x12mm E-thru
- ◆ 155mm Rear travel
- ◆ VPP - AM



● **CF6 - 209**

- ◆ Carbon UD
- ◆ 27.5 / 150x12mm E-thru
- ◆ 208mm Rear travel
- ◆ 4BAR - Down Hill



● **CF6 - 207**

- ◆ Carbon UD
- ◆ 27.5+ / 148x12mm E-thru
- ◆ XC



**GV-8000 (Gravel)**



Titanium 3AL/2.5V, Gravel frame  
 700C\*tire(35/38/40/42/45/52mm)  
 Option: Cr-Mo material

**TT-7146F**



**Time Trial frame kit**  
 Full carbon parts  
 W/fork & seat post & aero TT bar

**TK-7151**



**Alloy 700C e-bike**  
 For SHIMANO motor  
 Option: BOSCH motor

**RC-7010**



**700C carbon frame**  
 Internal cable routing ,1.5" H/T  
 Super light , weight: 850g / 52cm  
 Fork weight: 400g

**TR-7001**



**TRACK**  
 7005 Double butted tubing  
 Dropout: With stainless plate  
 Welding: TIG or Smooth  
 Option: CR-MO tube available

**AERO B01**



**Clip-on BAR, 6061 ALLOY**  
 Clipper size: 31.8, 26mm

**AERO B06**



**Time Trial aero bar**  
 Full carbon ,W/soft pad & extension tube  
 Center Clamp Diameter: 31.8mm



**THE EXCELLENT R&D TEAM**

Fax: 886-2-2505-7663, 2505-9771

E-mail: shinwhel@shinee.com.tw

Website: www.itek bikes.com

**Model: 18 E-8000 AM**

SHIMANO E-8000 AM

I.G. D/T, Motor Bottom Cover

27.5 Boost / 29er Two-in-One

Travel: R=150 / F=160mm, Shock: 200L / TR57

Frame size:(C-T) 15" / 17" / 19" / 21.5"



**Model: 18 XC AM**

Bosch CX

Travel: F/R=140mm, Shock: 190L / TR50.8

Available: 1) I.G. D/T, with Motor Bottom Cover

2) Power in Tube





**Model: 18 E-8000 AL-1**

SHIMANO E-8000, I.G. D/T  
Available in 27.5" / 27.5" Boost / 29er  
Frame size: To Order



**Model: 18 Brose AL-1**

Brose Motor with BMZ UR-V7 Battery  
Available in 27.5" / 27.5" Boost / 29er  
Frame size: To Order

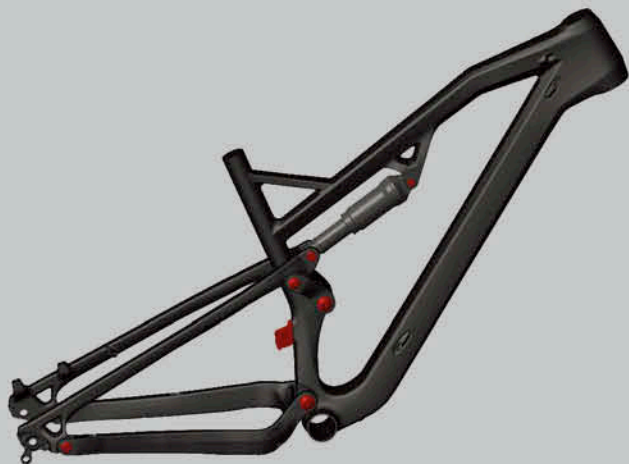

**Model: 18 XC-SUSP CA-1**

Exclusive high modulus carbon  
**27.5 Boost / 29er Two-in-One**  
Travel: R=110 / F=120mm, Shock: 190L / TR50.8  
Frame size: (C-T) 15.5" / 17.5" / 19" / 21"  
Press Fit BB92, Internal Cable routing



**Model: 29er-15**

Exclusive high modulus Full Carbon XC  
Weight: 1.25kg (17.5")  
Frame size: 29" x 15.5 / 17.5 / 19 / 21"  
Tapered H/T (1-1/8" to 1.5"), PM-Disc on C/S  
Press Fit BB92, Internal Cable routing  
**Available with Di2 version!**



**Model: 18 Road CA-1**

Exclusive high modulus carbon  
1-1/8" to 1.5" tapered H/T, PressFit BB86  
Frame size: 44 / 47 / 50 / 53 / 56 / 59cm (C-T)  
Internal Cable routing



**Model: 16 ROAD DISC-CA2**

Exclusive high modulus carbon  
Weight: Frame: 950g (50CM) / Fork: 400g / Post: 250g  
Frame size: 47 / 50 / 53 / 56 / 59 / 61cm (C-T)  
1-1/8" to 1.5" tapered H/T, **Shimano Flat-Mount Disc**  
**Caliper version is also available!**

# FRAME



## 7RP Rim Brake/Disc Brake

**Description** 700C Road/CX Carbon Frame  
**Finish** UD/3K/12K  
**Size** 48/51/54cm  
**BB System** BSA/BB30/PF30/BB86/BB386  
**Weight** 1,050g(Rim Brake)/1,100g(Disc Brake) ± 50g(51cm)  
**Headset** 1 1/8" Upper 1 1/2" Bottom (FSA No.42/48CF/ACB)  
**Max Tire Clearance** 700C \* 25C(Rim Brake) / 700C \* 28C(Disc Brake)



## 7RG

**Description** 700C Carbon Gravel Bike Frameset  
**Finish** UD  
**Size** 50/52/54/56/58cm  
**Weight** 1,080g ± 50g (54cm)  
**BB System** BSA / PF30 / BB86  
**Headset** 1 1/8" Upper 1 1/2" Bottom (FSA No. 42/ACB)  
**Rear Axle** M12 \* 142 \* 700C 41C(MAX)



## 6XF-XC/AM

**Description** 27.5" Full Suspension Cross Country/  
All Mountain Carbon Frame  
**Finish** UD  
**Size** 15.5"/17.5"/19"  
**Weight** 2,030g ± 50g (17" XC)/ 2,550g ± 50g (17" AM)  
**BB System** BB92  
**Headset** 1 1/8" Upper 1 1/2" Bottom (FSA No. 57)  
**Rear Axle** M12 \* 142mm \* 2.35"(XC)/ M12 \* 148mm \* 2.4"(AM)  
**Travel** F 100mm. R 110mm(XC)/ F150mm. R150mm(AM)  
**Shock** 22.2 \* 190mm(XC)/ 22.2 \* 200mm(AM)



## HB-R31.8-AW

Carbon Road Bar – Aero Wing  
( Internal Cable Routing w/ Cap )



## HB-M31.8-SL

Carbon MTB XC Flat Bar



## SPFC1-27.2/ 31.6

Monocoque Full UD Seat Post w/ 1 Bolt Alloy Clamp

## SPFC2-27.2/ 31.6

Monocoque Full UD Seat Post w/ 2 Bolt Alloy Clamp





# CKT<sup>®</sup>

## LIFE ON A BIKE



||||| CTK-369



||||| Grade



||||| CTK-579



||||| Fighter+E



||||| CTK-589V



||||| Challenger+E

Sunny Crown Enterprises Co., Ltd.

E-mail: [sunnycrn@ms49.hinet.net](mailto:sunnycrn@ms49.hinet.net) [cktbike@yahoo.com.tw](mailto:cktbike@yahoo.com.tw) Web: [www.ckt-bike.com](http://www.ckt-bike.com)

No.11, Lane 112, Kulin St., Kaohsiung, Taiwan Tel.: 886-7-3352000. 3361546 Fax: 886-7-3361547



TEL : 886 4 2688 0469  
 FAX : 886 4 2686 1238  
 ADD : #117 East West 3th Road  
 Da An Dist, Taichung City, Taiwan  
 Website : www.venzobike.com  
 E-mail : venzobike@vip.163.com

**VENZO™**  
 BICYCLE COMPONENT  
**VENZO CYCLE CO., LTD.**  
 Your Life Your Choice



29er  
**X.0** VZ-B01M-103

- |  |   |   |
|--|---|---|
|  RED   BLACK    |  PINK   BLACK  |  TEAL   BLACK   |
|  ORANGE   BLACK |  GREEN   BLACK |  YELLOW   BLACK |

**ELEMENTO LTD**



29er  
**X.0** VZ-B01M-099

- |  |  |  |  |
|--|--|--|--|
|  BLACK   RED  |  BLACK   GREEN  |  BLACK   YELLOW |  BLACK   BLUE |
|  BLACK   PINK |  BLACK   ORANGE |  BLACK   TEAL   |  |

**X.0**



29er  
**RAPTOR EVO** VZ-B01M-106

- |  |  |   |   |
|--|--|---|---|
|  BLACK   RED    |  BLACK   BLUE |  BLACK   GREEN |  BLACK   WHITE |
|  BLACK   YELLOW |  BLACK   TEAL |  RED   BLUE    |  ORANGE   BLUE |
|  BLUE   RED     |  TEAL   RED   |  BLUE   ORANGE |  TEAL   ORANGE |

**RAPTOR EVO**

29er  
**ECO-VA** VZ-B01E-002

- |   |  |   |  |
|---|--|---|--|
|  BLACK   RED |  BLACK   TEAL |  BLACK   GREEN |  BLACK   ORANGE |
|---|--|---|--|

**eco-va**



TEL : 886 4 2688 0469  
 FAX : 886 4 2686 1238  
 ADD : \*117 East West 3th Road  
 Da-An Dist, Taichung City, Taiwan  
 Website : www.venzobike.com  
 E-mail : venzobike@vip.163.com

**VENZO™**  
 BICYCLE COMPONENT  
**VENZO CYCLE CO., LTD.**  
 Your Life Your Choice



**Road Shoes** VZ-F30R-010

**MTB Shoes** VZ-F30M-010

**MTB Shoes** VZ-F30M-011

**Road Shoes** VZ-F30R-011



**Sunglasses** VZ-F27-014



**Sunglasses** VZ-F27-012

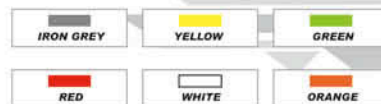

**SDX** VZ-F21-042

**SDX**



**MXR** VZ-F29-009



Y  
M  
C  
O  
T



**HK-SM-01**

**KH-HU-02F**

**HK-PD-02**

**HK-PG-02**

**KH-GP-01-MIX**

**HK-PD-03**



**KH-TR-03**



**KH-GP-03-MIX**



**KH-CK-02**



**KENCH**  
KENCH BIKE CO., LTD

#117 East West 3rd Road, Ta-An Dist, Taichung City, Taiwan.  
Tel: +886-4-2688-0469 Fax: +886-4-2686-1238  
kenchbike@gmail.com www.kenchusa.com



www.kenchusa.com



# 鶴明科技有限公司 HEMING TECHNOLOGY CO., LTD.

桃園市桃園區同德七街80號8樓  
8F., #.80, TONGDE 7TH ST., TAOYUAN CITY,  
TAOYUAN COUNTY 330, TAIWAN

TEL: +886-3-3023010 FAX: +886-3-3020012

http://www.heming.21tw.net E-mail: heming49@gmail.com

heming9125@gmail.com

- 複合材料科技，碳纖維產品成型用氣袋
- 專業配合海空運、費用、效率最安心
- 老店老字號、專業生產最牢靠
- 技術升級、品質升級、服務升級

- Nylon tubes, especially for carbon fiber products and technology using composites.
- Working together using professional low cost, high efficiency sea and air freight.
- You can rely on our specialized and experienced production.
- High quality, high tech, excellent service.





**BA&W International**  
**宇衡國際股份有限公司**

2F, No. 22, Zhong Shan N. Rd., Sec. 7,  
111 Taipei, Taiwan  
TEL / 886-2-28736998 FAX / 886-2-28714688  
E-mail:alfonso@bawintl.com



**JAVA**

**NESS™**

CARBON ENGINEERING



### MF-S8000E

**27.5" PLUS FULL CARBON E MTB FRAME**  
**SHIMANO STEPS E8000 SYSTEM**  
**E8020 INTERNAL BATTERY COMPATIBLE**  
**420MM / 470MM / 515MM / 565MM**



### MF-290N

**29" FULL CARBON MTB FRAME**  
**405MM / 444MM / 495MM / 545MM**



### MF-650N

**27.5" FULL CARBON MTB FRAME**  
**381MM / 432MM / 483MM / 533MM**



### AP-09

**700C FULL CARBON RACING FRAME SETS**  
**430MM / 460MM / 480MM / 500MM / 520MM / 540MM / 560MM**



### AP-11

**700C FULL CARBON RACING FRAME SETS**  
**450MM / 480MM / 510MM / 540MM / 570MM / 600MM**



### TT-19

**FULL CARBON TT FRAME SETS**  
**475MM / 500MM / 523MM / 546MM**



**FK-397DS-TX**  
**FULL CARBON GRAVEL /**  
**CYCLE CROSS FORK**

STEM : 1-1/8 - 1-1/2  
 AXLE-TO-CROWN : 397MM  
 BRAKE : FLAT MOUNTS DISC BRAKE  
 DROP OUTS : 12MM \* 100MM THRU AXLE  
 RAKE : 45MM



**FK-380DS-TX**  
**FULL CARBON RACING FORK**

STEM : 1-1/8 - 1-1/2  
 AXLE-TO-CROWN : 380MM  
 BRAKE : FLAT MOUNTS DISC BRAKE  
 DROP OUTS : 12MM \* 100MM THRU AXLE  
 RAKE : 45MM



**FK-AP11DS-TX**  
**FULL CARBON RACING FORK**

STEM : 1-1/8 - 1-1/2  
 AXLE-TO-CROWN : 370MM  
 BRAKE : FLAT MOUNTS DISC BRAKE  
 DROP OUTS : 12MM \* 100MM THRU AXLE  
 RAKE : 45MM



**FK-AP11DM-QR**  
**FULL CARBON RACING FORK**

STEM : 1-1/8 - 1-1/2  
 AXLE-TO-CROWN : 370MM  
 BRAKE : DIRECT MOUNTS BRAKE  
 DROP OUTS : 9MM \* 100MM QR  
 RAKE : 45MM



**FK-AP11DS-QR**  
**FULL CARBON RACING FORK**

STEM : 1-1/8 - 1-1/2  
 AXLE-TO-CROWN : 370MM  
 BRAKE : FLAT MOUNTS DISC BRAKE  
 DROP OUTS : 9MM \* 100MM QR  
 RAKE : 45MM



**FK-370DS-QR**  
**FULL CARBON RACING FORK**

STEM : 1-1/8 - 1-1/2  
 AXLE-TO-CROWN : 370MM  
 BRAKE : FLAT MOUNTS DISC BRAKE  
 DROP OUTS : 9MM \* 100MM QR  
 RAKE : 45MM



**FK-AP11CB-QR**  
**FULL CARBON RACING FORK**

STEM : 1-1/8 - 1-1/2  
 AXLE-TO-CROWN : 370MM  
 BRAKE : CALIPER BRAKE  
 DROP OUTS : 9MM \* 100MM QR  
 RAKE : 45MM



**FK-38CB-QR**  
**FULL CARBON RACING FORK**

STEM : 1-1/8 - 1-1/2  
 AXLE-TO-CROWN : 370MM  
 BRAKE : CALIPER BRAKE  
 DROP OUTS : 9MM \* 100MM QR  
 RAKE : 45MM



**FK-34AC-QR**  
**ALLOY CARBON RACING /**  
**FIXIE / TRACK FORK**  
 STEM : ALLOY / 1-1/8  
 AXLE-TO-CROWN : 363MM -370MM  
 BRAKE : CALIPER BRAKE / NO BRAKE HOLE  
 DROP OUTS : 9MM \* 100MM QR  
 RAKE : 35MM -40MM



**FK-36AC-QR**  
**ALLOY CARBON RACING FORK**  
 STEM : ALLOY /1-1/8 - 1-1/2  
 AXLE-TO-CROWN : 370MM  
 BRAKE : CALIPER BRAKE  
 DROP OUTS : 9MM \* 100MM QR  
 RAKE : 45MM



**XP-13C**  
**FULL CARBON FLAT BAR**  
 BAR BORE : 31.8MM  
 WIDTH : UP TO 800MM

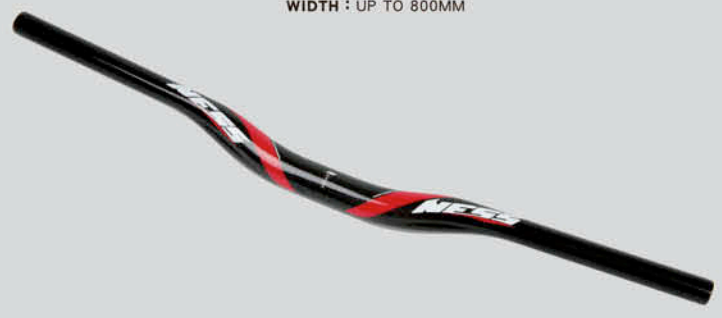

**XP-14C**  
**FULL CARBON RISE BAR**  
 BAR BORE : 31.8MM  
 WIDTH : UP TO 800MM



**XP-28C**  
**FULL CARBON INTEGRATED BAR**  
 DROP : 130MM / REACH : 76MM  
 E : 90MM / 100MM / 110MM / 120MM / 130MM  
 W : 400MM / 420MM / 440MM



**XP-48C**  
**FULL CARBON INTEGRATED BAR**  
 DROP : 130MM / REACH : 76MM  
 E : 90MM / 100MM / 110MM / 120MM / 130MM  
 W : 400MM / 420MM / 440MM



**XP-08C**  
**FULL CARBON COMPACT ROAD BAR**  
 BAR BORE : 31.8MM  
 DROP : 130MM / REACH : 76MM  
 W : 400M / 420MM / 440MM



**XP-09C**  
**FULL CARBON COMPACT ROAD BAR**  
 BAR BORE : 31.8MM  
 DROP : 130MM / REACH : 76MM  
 W : 400MM / 420MM / 440MM



**XP-AL02N**  
**ALLOY COMPACT ROAD BAR**  
 BAR BORE : 31.8MM  
 DROP : 130MM / REACH : 76MM  
 W : 400M / 420MM / 440MM



**XP-30N**  
**FULL CARBON SADDLE**



接著劑第一首選

# 無可撼動的牢固

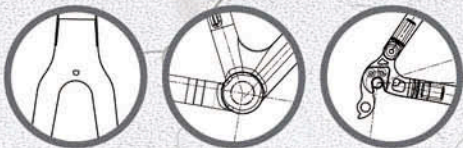

**EVERWIDE**

金屬、複材接著  
堅韌、耐衝擊、抗剝離

The expert of adhesives for metal and carbon fiber.  
Stability, Excellent shear, peel and impact strength.



亨晏企業有限公司  
HENG YEN ENTERPRISE CO., LTD.  
● [www.hengyen.com.tw](http://www.hengyen.com.tw)

40755台中市西屯區朝馬路152號  
No.152, Chaoma Rd., Xitun Dist., Taichung City 407, Taiwan  
TEL: 886-4-22521450 FAX: 886-4-22521447





Mini Bell



OIL SLICK COLOR: PURPLE / BLUE / GREEN



COLORS:  
STANDARD: GOLD/BLACK,  
SPECIAL: BLACK CP / BRASS BRASS / CP.



OIL SLICK COLOR:  
PURPLE / BLUE / GREEN



COLORS:  
GOLD / BLACK.



SHERPA CS-3339  
BIKE FOLDING STAND  
FOR 26"/29".



CL-BELL-AN  
NEW CLIP TYPE MINI BELL (ON RUBBER HOOD),  
360 DEGREE HAMMER DESIGN.



CL-BELL-AG  
NEW STRAP TYPE MINI BELL,  
360 DEGREE HAMMER DESIGN.



ULTIMATE-NCS-GG



SPECIAL DESIGN FOR:  
UPPER: GARMIN BASE HOLDER,  
LOWER: GO-PRO ADAPTER  
(ANGLE ADJUSTABLE).  
FITS ON HANDLE BAR STEM.  
FULL CNC, AMMO. BLACK.



MOTO PINS  
FLIP PINS FOR:  
BIKE: 8mm.  
MOTO: 10mm.  
SPECIAL OIL SLICK COLORS:  
PURPLE / BLUE / GREEN



EYED-QRL-N/B  
FRONT OR REAR LED LIGHT,  
QR DESIGN, FOR QR AXLE.  
N: USE CR-2 BATTERY.  
B: USE CR-1632 BATTERY.



MORE ITEMS,  
PLEASE VISIT OUR WEBSITE.



CYCLE LUCHA CO., LTD TEL:+886 49 232 0951 FAX: +886 49 232 0928

E-mail:jimmychan@clcl.com.tw Web:http://clcl.com.tw Attn: Jimmy Chan

# DISPLAY STANDS



**STD-BIKE-4**



**STD-BIKE-4E**



**STD-WHEEL**



**A-SW-B AR**  
HANDLE BAR HOLDER FOR SLATWALL.



**A-SW-STEM**  
HANDLE BAR STEM HOLDER FOR SLATWALL.



**A-SW-DBR**  
DISC BRAKE HOLDER FOR SLATWALL.



**A-WHL-ADP**  
FOR QR9/12/15/20mm AXLE.



**A-SW-POST**  
SEAT POST HOLDER FOR SLATWALL.



**STD-MN-W2N**  
2-WHEEL MINI HOLDER,  
FOR QR/12/15/20mm AXLE.



**A-SW-W2N**  
2-WHEEL HOLDER FOR SLATWALL,  
FOR QR/12/15/20mm AXLE.



立銘

E-mail: [btwb017@biketaiwan.com](mailto:btwb017@biketaiwan.com)

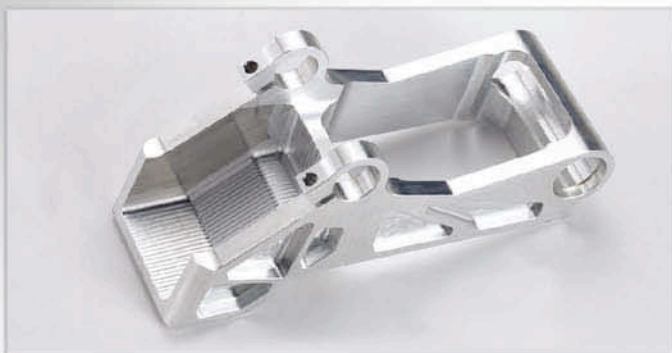

BEZ101

**BLUE BIRD METAL CO., LTD**

No. 807, Changho Rd., Homei chen 508, Changhua Hsien, Taiwan

TEL: 886-4-7362261 FAX: 886-4-7362263

E-mail: [blue6190@ms18.hinet.net](mailto:blue6190@ms18.hinet.net)



BEZ102 BEZ103



BEZ104 BEZ105



BEZ106 BEZ107



BEZ108 BEZ109



BEZ110 BEZ111



BEZ112 BEZ113



BEZ114 BEZ115



BEZ116 BEZ117



BEZ118 BEZ119

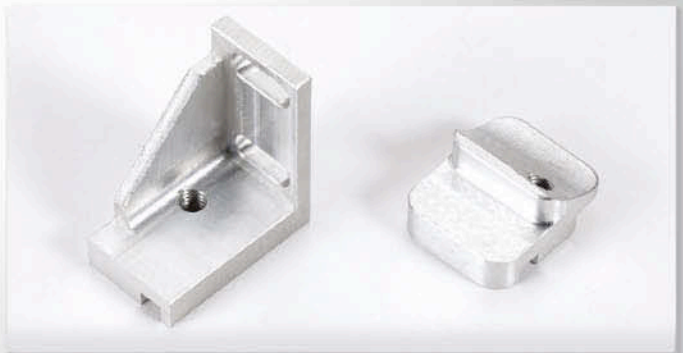

BEZ120 BEZ121



BEZ122 BEZ123



BEZ124 BEZ125



BEZ126 BEZ127



BEZ128 BEZ129



久 陞  
久 升

**JUESON LAI ENTERPRISE CO., LTD.(Taiwan)**  
 Tel: 886-4-25316188 Fax: 886-4-25327260  
 E-mail: jusson88@tcts.seed.net.tw  
 Add: No.7, Ln. 43, Decai St.,Tanzi Dist.,  
 Taichung City 42745, Taiwan.  
**Dongguan, China**  
 Tel: 86-769-87724858  
 Fax: 86-769-87724758, 87989810  
 E-mail: dgjushen@21cn.com  
**Taicang, China**  
 Tel: 86-512-53456501 Fax: 86-512-53456502  
 E-mail: jiuhe\_cn@163.com







For more information, you can check our website



CL3200A

CL3205B

CL3206A

CL3204

CL3201



NEW

NEW

CL3798

CL3799

CL3401

CL3402

CL3403



CL3404

CL3405

CL3409

CL3410

CL3411



NEW

NEW

CL3802A1

CL3802B1

CL3803B2

CL3803B2A

CL3901

CL3903



CL3470, CL3471

CL3501

CL3502

CL3599

CL4070

CL4080



NEW

CL3701

CL3702

CL3703

CL3704

CL3705

CL4100

CL4101



NEW

NEW

PAT NEW

CL4121

CL4131

CL4133

CL4134

CL4140

CL4141

CL4205



CL4010

CL4011

CL4020

CL4050

CL4031

CL4162

CL4172

**KUOMEX**

鑫億合

**KUOMEX CO., LTD**

No.1606, Sec. 1, Zhongshan Rd., Dajia Dist.,

Taichung City 43755, Taiwan

Tel: 886-4-26866519

Fax: 886-4-26882281

E-mail: kuomex@msl.hinet.net

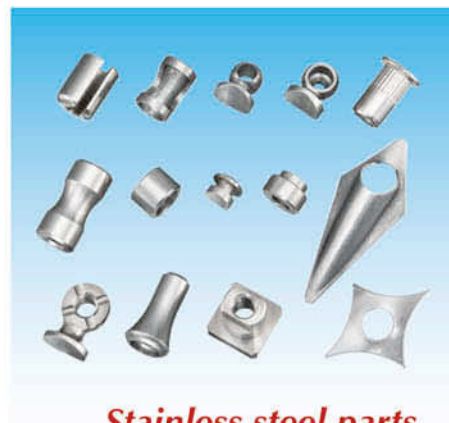



# VERTECH

YOZU METAL (SHEN ZHEN) LTD.



[www.vertech.com.cn](http://www.vertech.com.cn)

# “BOUTIQUE PRODUCT,”

Vertech's customers have learned to expect the highest quality products from us. Our design, manufacturing and quality systems insure that we deliver on those expectations. From the smallest, simplest parts to larger, more complex assemblies, our philosophy is the same. Everything we make must meet our customer's highest standards for dimensional accuracy, material consistency, quality, finish, and on time delivery. In other words, What you want, when you want it.



友志五金車料（深圳）有限公司  
深圳寶安區沙井鎮大王山第三工業區 11 號  
No. 11 Da Wang San Third Industry Area, Sha Jing Town,  
Bao An County, Shen zhen, China  
TEL: 86-755-27225099  
FAX: 86-755-27225607  
E-mail: [info@vertech.com.cn](mailto:info@vertech.com.cn)

友穎商通股份有限公司  
42849, 台中市大雅區光復路 16-6 號  
No16-6, Guangfu Rd., Daya Dist.,  
Taichung City, 42849, Taiwan  
TEL: 886-4-25665411  
FAX: 886-4-25665872  
E-mail: [ad@u-logis.com.tw](mailto:ad@u-logis.com.tw)

友富五金車料（越南）責任有限公司  
越南平陽省濱吉市安西鄉寶翠工業區 3B 號路 17-6 號  
Lot 17-6, 3B Road, International Protrade Industrial Park, An  
Tay Town, Ben Cat District, Binh Duong Province, Viet Nam  
TEL: 84-6503585853  
FAX: 84-6503585856  
E-mail: [info@vertech.com.vn](mailto:info@vertech.com.vn)



93-033-700  
For BOSCH



93-042-670  
For BOSCH



93-043-700  
For BOSCH CX



93-044-700SM  
For BOSCH CX

NEW



93-080-880  
Bosch G4



93-081-900  
For Continental



93-083-1000  
For SHIMANO



93-084-670  
For SHIMANO



93-029-2194  
For BROSE



93-050C-710SM  
For SHIMANO



14-218A-560RSM



14-218-560SMA

### Internal Welding Cable Stopper



11-299-310



11-298-210



11-297-000F



12-299-200F

### Plastic Cable Stopper/guide



812-300-000C



812-300-000B



812-300-000G



811-560-000L



811-452-000R



811-455-000C



811-455-000D



811-455-000B



812-024A-040SM



811-128E-000Y



811-024-050SM



12-302-380SM



11-302-340SM



12-149-000



12-306ZD-260

### For E-Bike



13-303-220SM



13-304-450SM



12-304-260SM



12-302-390SM



12-303-390SM



91-016-150



91-100-100



37-448-XXX



NEW



14-225-100LR



14-182-530LR



14-220-530LR



14-193-530LR



14-300-530LR



14-181-530SM



14-150-080



14-048A-540ALYSM



14-048A-540C



14-048A-540LYSM



14-048B-540RY



14-048B-540RAY



14-165-624SM



14-165A-624SM



14-165B-624SM



14-192-530SMA



14-192-530SMB



14-214-530



14-213-530SM



14-212-530SM



14-165-624LR



14-216-530SM



14-048B-540L



14-048C-540R



14-048D-540L



14-048A-540R



14-216-155



14-135B-660LR



14-130-530LRSM



14-131A-530LR



14-205-530SM



14-150-560LR



14-178-650LRSM



14-162-600L



14-162-600R



YZ-CB-24



YZ-CB-25



YZ-CB-26



YZ-CB-14B



YZ-CB-09



YZ-CB-08A



YZ-ZGQF-20(83)



YZ-ZGQF-20(100)



YZ-ZGQF-20(120)



YZ-ZGQF-20(68)  
35.4



(28.6/29.8/31.8)  
30-101-175C



YZ-ZGQF-02



YZ-ZGQF-30



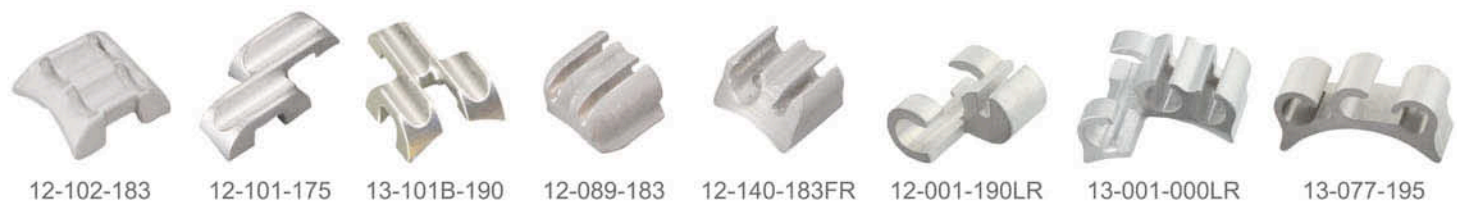



YZ-CD-02



YZ-CD-03



YZ-CD-07



YZ-CD-09



YZ-CD-13



12-111-120SM



YZ-QR-25



73-122B-710SM



YZ-CTW-20(50)



33-049C



41-008B-300



32-058-210



32-001-320



31-038-160GH



50-004



50-025A-150



50-024-150



50-002-R



50-006-R



50-602-



50-030



30-040-250



30-050-260



38-013-510I



35-008-150



50-032-R



31-001B-350



47-054A-300P



35-045-+++



35-106A-650



35-107-460



35-035-700



35-028



35-004D



35-003-500



37-021A-250



37-021-225



46-043-220



36-185-079



36-366-118



73-041B-380



73-038A-020



35-010-336-560



37-079



37-039-600



W=30.5 37-037-L1/L2  
W=32.5 37-038-L1/L2



91-017-052AB



74-003-285



73-016-402



73-022-260



42-800-001



42-801-001



42-802-001  
E6000



42-803-001  
E8000 A OR B COVER



42-803-003  
42-803-004MBK  
(E8000)



42-804-000  
(E7000)



42-804-001  
42-804-002MBK  
(E7000) City and Trekking



42-805-000  
(E6100)



42-805-001  
42-805-002MBK  
(E6100) City and Trekking



14-802-001L



14-802-001R+



14-801-001L



14-801-001R+



72-122D-1711HABK+(142)  
72-122D-1771HABK+(148)



14-800-003L



14-800-003R



14-800-001L+



14-800-001R+



14-183-000L



14-183-000R  
+  
14-183-000RH2



14-183-000R  
+  
14-183-000RH1



14-184-000L



14-184-000R  
+  
14-184-000RH1



38-806-001MBK



38-805-001MBK



13-205-000G



13-205-000F



11-800-000



11-800-000G



11-801-001  
(7X23)



11-802-000  
(7X18)



99-800-022





99-801-003



99-801-004



99-801-005



99-801-006



99-801-007  
(E8000)



99-802-019+



14-147-001MB



14-800-000MB



14-801-XXXMB+



99-803-XXX



38-804-001MB



14-800-001L



14-800-001R



14-800-001RHBK



14-800-001LHBK



63-800-000L/R



12-151-000BBK



12-151-000EBK



12-151-000F



12-174-000F



12-174-000GBK+1



**Nylon**  
211-149-095GB



11-149A-095G



11-149B-095G



11-202B-000



11-202D-000



11-202G-000



11-402-000GBK



11-452-000A



11-452-000BBK



11-452-000CBK



11-452-000DBK



11-460-000YBK



11-455-002F  
(For Welding)



11-452-002F  
(For Welding)



11-455-000KBK



**Nylon**  
12-142-000



12-144-000BK



12-145-000G



12-146-000



12-147-000G



11-104-\*\*\*YBK



11-105-\*\*\*HYBK



11-125-\*\*\*YBK



11-125F-095YBK+



**Nylon**  
211-125F-095YB+



11-128E-\*\*\*YBK











51-\*\*\*\_\*\*\*



53-\*\*\*\_\*\*\*



54-\*\*\*\_\*\*\*



55-\*\*\*\_\*\*\*



57-\*\*\*\_\*\*\*\_\*\*\*



50-490-317YMB



93-102-074+



45-108-350BK+



41-103-280BK



41-103-165BK



41-103-075BK



41-114-000BK  
582-060S-120-4B



40-102-440BK+



45-440-31649BK+



45-455-308BK+



45-480-341MB+



45-480B-349



45-111-350BK+



45-481-300BKL+



45-113-318BK+



45-102-272318BK+



45-102-316349BK+



45-103-318BK+



92-010-286SV+



72-101-170B  
(M10X1.25)



72-101-335A  
(M10X1.25)



72-105-335FA  
(M10X1.0)



72-111-310A  
(M10X1.25)



45-101-318+



45-105-318BK+



72-100-1355GD+



72-120-1730GD+



94-101-029+



94-102-411BK+



94-103-412BK+



YZ-QR001C-174BK+



YZ-QR001B-174BK+



YZ-QR005-5180SV+



YZ-QR005-5148SV+



# FORK TERMINOLOGY

- A: Length of fork stem
- B: Length of stem thread
- C: Diameter of cone race
- D: Diameter of brake hole
- E: Type of dropout
- L: Length of blades  
(from center of brake hole to center of hub axle)
- L1: Lower length
- G: Crown race diameter
- H: Offset
- K: Height of pivots
- PW: Width of pivots
- TW: Tire clearance
- ID: I.D. of fork stem
- M: Type of slot
- F: Height of low rider boss
- P: Height of dynamo bracket

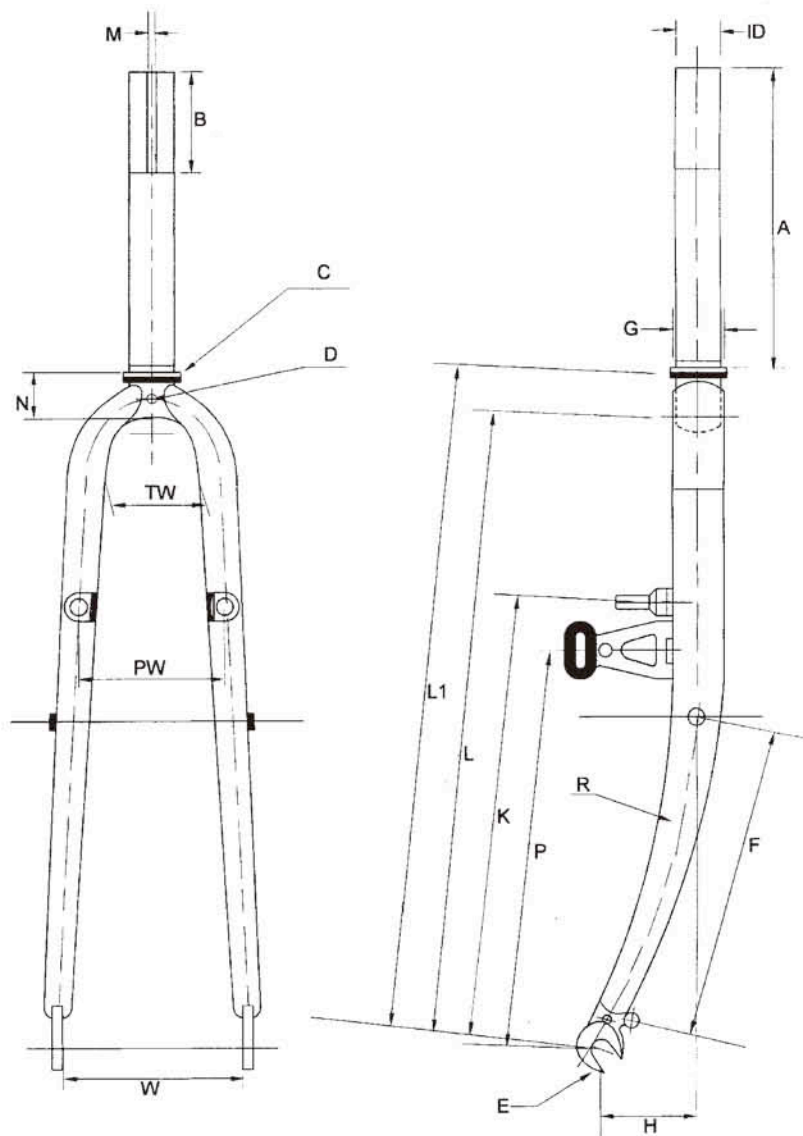



26/27.5/29  
AM/Freeride  
TRAVEL 140-160

**Axle**  
15 x 100  
20 x 100

## USD-6



26/27.5  
AM/Freeride/Fat bike  
TRAVEL 100-120

**Axle**  
15 x 150

## USD-6 FAT



Wire control

Manual control



26/27.5/29  
XC  
TRAVEL 100

**Axle**  
9

## OSL

Air pressure can be adjust by customer



Air pressure can be adjust by customer



26/27.5/29  
Downhill/Freeride  
TRAVEL 150-203

**Axle**  
20 x 110

## USD-8 SA



26/27.5  
Fat bike/Downhill/  
Freeride

**Axle**  
15 x 150  
20 x 150

## USD-8 FAT

**DNM INDUSTRY CO., LTD.**

Tel : +886 4 22706191

Fax : +886 4 22708734

dnm@dnmshock.com



dnmshock.com



XC/TRAIL/AM  
LENGTH/TRAVEL  
165 / 38  
190 / 51  
200 / 57

### AO-42RC



XC/TRAIL/AM  
LENGTH/TRAVEL  
165 / 38  
190 / 51  
200 / 57

### AO-42AR



XC/TRAIL/AM  
LENGTH/TRAVEL  
165 / 35  
190 / 50  
200 / 55

### AOY-36RC



### RCP-2S

Downhill/Freeride/AM  
LENGTH/TRAVEL  
190 / 51  
200 / 56  
210 / 61  
220 / 66  
240 / 76  
265 / 86



### RCP-2AR

Downhill/Freeride/AM  
LENGTH/TRAVEL  
190 / 51  
200 / 56  
210 / 61  
220 / 66  
240 / 76  
265 / 86



### CSP

Diameter 27.2/30.9/  
31.6/34.9  
LENGTH/TRAVEL  
300 / 100  
380 / 125



### CSD

Wire control Head  
Diameter 27.2/30.9/  
31.6/34.9  
LENGTH/TRAVEL  
300 / 100  
380 / 125



**DV-22**  
FOR XC



**DV-6**  
FOR XC



**DV-6S**  
FOR Wheel Chair

**DNM INDUSTRY CO., LTD.**



2018



# APREBIC INDUSTRY CO.,LTD.

No.50, Sec.,1, Dongxi 7th RD., Dajia Dist., Taichung City 437, Taiwan

TEL: (886)4-26884088

FAX: (886)4-26884077

E-mail: aprebic@evo.com.tw

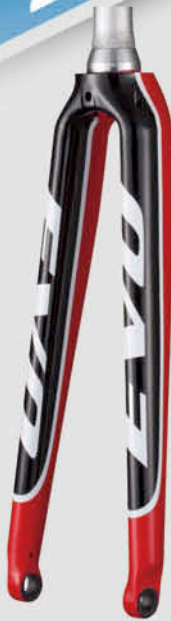

**ARC-D765/D763/A765/A763**  
**ARL-D766/D764/A766/A764**

**700C Carbon Racing Fork  
W/Flat Mount**

**Steer:** 1 1/2" alloy or 1 1/8" alloy  
**Integrated:** 56mm or 50mm  
**Offset:** 43-47mm  
**Tire clearance:** 45mm  
**Weight:** 660g  
**Option:** Internal routing, QR,  
or 12/15mm Thru-axle



**ARC-A775/D775**  
**ARC-A810/D810**

**700C Carbon Racing Fork  
W/Post Mount**

**Steer:** 1 1/8" or 1 1/2" Alloy  
**Integrated:** 50mm/56mm  
**Offset:** 45mm  
**Tire clearance:** 35mm  
**Weight:** 525g  
**Option:** QR or 12/15mm Thru-Axle



**ARC-D737**

**700C Carbon Racing Fork**

**Steer:** 1 1/2" Alloy  
**Integrated:** 56mm  
**Offset:** 43-50mm  
**Tire clearance:** 36mm  
**Weight:** 645g



**ARC-D738/B738/D791**  
**ARL-D788**

**700C Carbon Racing Fork**

**Steer:** 1 1/4" or 1 1/2"  
**Integrated:** 52 or 56mm  
**Offset:** 35-50mm  
**Tire clearance:** 35 or 45mm  
**Weight:** 710g  
**Option:** 20" / 24", Post Mount, Alloy Blade



**ARC-D741**  
**ARL-D742/D7491**

**700C Carbon or Alloy Racing Fork**

**Steer:** 1 1/2" Alloy (one piece crown design)  
**Integrated:** 56mm  
**Offset:** 45mm  
**Tire clearance:** 38mm  
**Weight:** 520g  
**Option:** Alloy Blade and smooth welding  
for bonded line



**ARC-D806**

**700C Monocoque Racing Fork**

**Steer:** 1 1/2"  
**Integrated:** 56mm  
**Offset:** 45mm  
**Tire clearance:** 35mm  
**Weight:** 355g

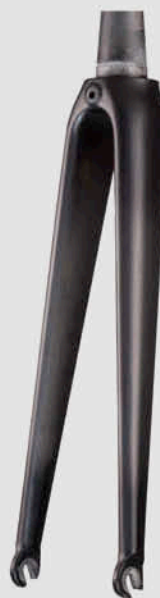

**ARC-D8050**

**700C Carbon Monocoque  
Racing Fork**

**Steer:** 1 1/2" Carbon  
**Integrated:** 56mm  
**Offset:** 45mm  
**Tire clearance:** 34mm  
**Weight:** 330g



**ARC-B721**

**700C Carbon Monocoque  
Racing Fork**

**Steer:** 1 1/4" Carbon  
**Integrated:** 52mm  
**Offset:** 45mm  
**Tire clearance:** 34mm  
**Weight:** 360g



**ARC-D743**

**700C Carbon Monocoque Racing Fork W/Post Mount**

Steer: 1 1/2"  
 Integrated: 56mm  
 Offset: 45mm  
 Tire clearance: 45mm  
 Weight: 420g



**ARC-D8009**

**700C Carbon Monocoque Racing Fork W/Flat Mount**

Steer: 1 1/2" Carbon  
 Integrated: 56mm  
 Offset: 45mm  
 Tire clearance: 45mm  
 Weight: 405g



**ARC-A631**

**ARL-A630**

**700C Carbon Racing Fork**

Steer: 1" or 1 1/8" Alloy  
 Integrated: 45 or 50mm  
 Offset: 43-50mm  
 Tire clearance: 35 or 42mm  
 Weight: 590g  
 Option: 20"/24", Alloy Blade



**ARC-A642**

**ARL-A640**

**700C Carbon Racing Fork**

Steer: 1 1/8" Alloy  
 Integrated: 45 or 50mm  
 Tire clearance: 35 or 42mm  
 Offset: 43-50mm  
 Weight: 560g  
 Option: 20"/24", Alloy Blade



**ARC-A651**

**ARL-A650**

**700C Carbon Racing/Track Fork**

Steer: 1 1/8" Alloy  
 Integrated: 45 or 50mm  
 Offset: 30-50mm  
 Tire clearance: 35mm  
 Weight: 700g  
 Option: Alloy Blade



**AKC-D813**

**700C Carbon Monocoque Track Fork**

Steer: 1 1/2" carbon  
 Integrated: 56mm  
 Offset: 40mm  
 Tire clearance: 45mm  
 Weight: 380g

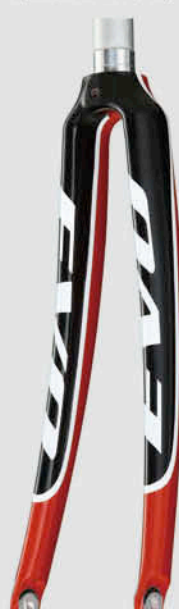

**ARC-A797**

**ARL-A796**

**700C Carbon Racing Fork**

Steer: 1 1/8" Alloy  
 Integrated: 46mm  
 Offset: 43-50mm  
 Tire clearance: 38mm  
 Weight: 670g  
 Option: Alloy Blade



**AMC-D781**

**AMC-D720**

**29er Carbon Monocoque MTB Fork W/Post Mount**

Steer: 1 1/2" Carbon  
 Integrated: 56mm  
 Offset: 45mm  
 Tire clearance: 72mm  
 Weight: 700g



2018



**APREBIC INDUSTRY CO.,LTD.**

No.50, Sec.,1, Dongxi 7th RD., Dajia Dist., Taichung City 437, Taiwan  
 TEL: (886)4-26884088 FAX: (886)4-26884077  
 E-mail: aprebic@evo.com.tw



**AMC-D807**

**650B Carbon Monocoque MTB Fork W/Post Mount**

Steer: 1 1/2" Carbon  
 Integrated: 56mm  
 Offset: 42mm  
 Tire clearance: 80 mm  
 Weight: 630g



**AMC-D7020**

**650B+ Carbon Monocoque MTB Fork W/Post Mount, 15mm Thru-Axle**

Steer: 1 1/2" Carbon  
 Integrated: 56mm  
 Offset: 51mm  
 Tire clearance: 106mm  
 Weight: 700g



**AMC-D9016**

**Carbon Monocoque Fat Bike Fork W/Post Mount, 15mm Thru-Axle**

Steer: 1 1/2" Carbon  
 Integrated: 56mm  
 Offset: 45mm  
 Tire clearance: 146mm  
 Dropout width: 150mm  
 Weight: 750g



**ACC-A613/D613**

**ACL-A614/D614**

**Carbon Trekking Fork W/Post Mount**

Steer: 1 1/8" or 1 1/2" Alloy  
 Integrated: 45 or 50 or 62mm  
 Offset: 43-48mm  
 Tire clearance: 56 or 75mm  
 Weight: 760g  
 Option: Pivot, IS Mount



**ACC-D783/D817**

**ACL-D784/D818**

**Carbon gravel fork w/flat mount**

Steer: 1 1/2" alloy one piece  
 Integrated: 56mm  
 Offset: 45mm  
 Tire clearance: 56mm  
 Weight: 655g  
 Option: Post Mount, Flat Mount, Allow Blade, Internal Routing, QR or 12/15mm Thru-Axle



**ACC-A750/D750**

**ACL-A753/D753**

**Carbon Gravel Fork W/Post Mount**

Steer: 1 1/8" or 1 1/2" Alloy  
 Integrated: 45 or 50 or 56mm  
 Offset: 43-52mm  
 Tire clearance: 54mm  
 Weight: 780g  
 Option: Pivot, IS Mount, Post Mount, Alloy Blade, Internal Routing, QR Or 12/15mm Thru-Axle



**ACC-D779**

**ACC-D752**

**Carbon Monocoque Gravel Fork W/Flat Mount And 12/15mm Thru-Axle**

Steer: 1 1/2" Carbon  
 Integrated: 56mm  
 Offset: 45mm  
 Tire clearance: 57mm  
 Weight: 430g  
 Option: Post Mount W/QR



**ACC-D8014**

**ACC-D8015**

**Carbon Monocoque Gravel Fork W/Flat Mount And 12/15mm Thru-Axle**

Steer: 1 1/2" Carbon  
 Integrated: 56mm  
 Offset: 45mm  
 Tire clearance: 75mm  
 Weight: 460g  
 Option: QR



**ACC-D815**  
**ACL-D816/D824**

**Carbon Gravel Fork W/Flat Mount**

Steer: 1 1/2" alloy  
 Integrated: 56mm  
 Offset: 43-52mm  
 Tire clearance: 75mm  
 Weight: 760g  
 Option: Flat Mount, Alloy Blade, Internal Routing, QR or 12/15mm Thru-Axle



**ACC-A657**  
**ACL-A658**

**Carbon Trekking Fork W/Pivot**

Steer: 1 1/8" Alloy  
 Integrated: 45 or 50mm  
 Offset: 43-48mm  
 Tire clearance: 54mm  
 Weight: 650g  
 Option: Alloy Blade



**ACC-A759**  
**ACL-A652**

**Carbon Cyclecross Fork W/Pivot**

Steer: 1 1/8" Alloy  
 Integrated: 50mm  
 Offset: 43-45mm  
 Tire clearance: 54mm  
 Weight: 650g  
 Option: Alloy Blade



**ACL-A6282**

**Alloy Cyclecross Fork**

Steer: 1 1/8" Alloy  
 Integrated: 45-50mm  
 Weight: 850g  
 Option: Pivot, IS Mount, Roller



**ACL-A83139**

**Alloy Gravel Fork**

Steer: 1 1/8" Alloy  
 Integrated: 45-50mm  
 Weight: 850g  
 Option: Pivot, IS Mount, Post Mount, 12/15mm Thru-Axle



**ACL-D8979**

**Alloy E-Bike Fork W/Post Mount, 12mm Thru-Axle**

Steer: 1 1/2" Alloy  
 Integrated: 62mm  
 Offset: 45mm  
 Weight: 780g



**AC-A61134**

**Crmo Gravel Fork**

Steer: 1" or 1 1/8" Crmo  
 Integrated: non-integrated or 40-50mm  
 Option: Pivot, IS Mount, Roller



**AM-A62104**

**Crmo MTB Fork**

Steer: 1 1/8" crmo  
 Integrated: 50mm  
 Tire clearance: 90mm  
 Option: Post Mount, 12mm Thru-Axle



**AM-A63107**

**Crmo MTB Fork**

Steer: 1 1/8" crmo  
 Integrated: 50mm  
 Tire clearance: 90mm

**ADK TECHNOLOGY LIMITED**  
<http://www.adktec.com>

E-mail: [kenneth@adktec.com](mailto:kenneth@adktec.com) / [alex@adktec.com](mailto:alex@adktec.com) Contact: Kenneth Yen / Alex Chen  
 Hui Zhou, Guang Dong, China Tel: 86-752-2323868 Fax: 86-752-2323863  
 No.792, Sec. 2, Taiwan Blvd., Xitun Dist., Taichung City 407, Taiwan Tel: 886-4-36069630 Fax: 886-4-36069633

**ROAD** →



Model	AKF032	AKF046	AKF053 (Thru-Axle)	AKF058	AKF066	AKF068
Type	Road 700C	Road 700C	Road 700C	Road 700C	Road 700C(28C)	Road 700C
Steerer	Alloy/Carbon 1 1/8"-1 1/2"	Alloy 1 1/8"	Alloy/Carbon 1 1/8"-1 1/2"	Alloy 1 1/8"	Alloy/Carbon 1 1/8"-1 1/2"	Alloy 1 1/8"
Race	39.8mm	30mm	39.8mm	30mm	39.8mm	30.6mm
Crown	Alloy/Carbon integrated Ø56	Alloy integrated Ø47	Alloy/Carbon integrated Ø56	Alloy integrated Ø45	Alloy integrated Ø56	Alloy integrated Ø47
Blade	3K/UDM Carbon Weave	3K/UDM Carbon Weave	UDM Carbon Weave	3K/UDM Carbon Weave	UDM Carbon Weave	UDM Carbon Weave
Dropout	Carbon/Alloy	Carbon W/POST MOUNT	Carbon W/FLAT MOUNT	Carbon/Alloy	Carbon	Carbon W/FLAT MOUNT
Offset	45mm/52mm	45mm	45mm/50mm	52mm	45mm	45mm

**E-BIKE** →

**GRAVEL** →

**CX** →



Model	AKF074	AKF056(Thru-Axle)	AKF071	AKF037	AKF038	AKF047
Type	E-BIKE	Gravel 700C	Gravel	Cycle Cross 700C	Cycle Cross 700C	Cycle Cross 700C
Steerer	Carbon 1 1/8"-1 1/2"	Alloy/Carbon 1 1/8"-1 1/2"	Carbon 1 1/8"-1 1/2"	Alloy/Carbon 1 1/8"-1 1/2"	Alloy/Carbon 1 1/8"-1 1/2"	Alloy 1 1/8"
Race	39.8mm	39.8mm	39.8mm	39.8mm	39.8mm	30mm
Crown	Carbon integrated Ø56	Alloy/Carbon integrated Ø56	Carbon integrated Ø57	Alloy/Carbon integrated Ø56	Alloy/Carbon integrated Ø56	Alloy integrated Ø45/50
Blade	UDM Carbon Weave	UDM Carbon Weave	UDM Carbon Weave	3K/UDM Carbon Weave	3K/UDM Carbon Weave	3K/UDM Carbon Weave
Dropout	Carbon W/Flat Mount	Carbon W/FLAT MOUNT	Carbon W/Flat Mount	Alloy/Carbon	Carbon W/POST MOUNT	Carbon W/POST MOUNT
Offset	45mm	50mm	50mm	45mm/50mm	45mm/50mm	45mm

**CX** →



Model	AKF048-N(Thru-Axle)	AKF052 (Thru-Axle)	AKF052-OR	AKF064(Thru-Axle)	AKF069	AKF070
Type	Cycle Cross 700C	Cycle Cross 700C	Cycle Cross 700C	Cycle Cross 700C	Cycle Cross 700C	Cycle Cross 700C
Steerer	Carbon 1 1/8"-1 1/2"	Alloy/Carbon 1 1/8"-1 1/2"	Alloy/Carbon 1 1/8"-1 1/2"	Carbon 1 1/8"-1 1/2"	Alloy 1 1/8"	Alloy 1 1/8"-1 1/2"
Race	39.8mm	39.8mm	39.8mm	39.8mm	30mm	39.8mm
Crown	Carbon integrated Ø56	Alloy/Carbon integrated Ø56	Alloy/Carbon integrated Ø56	Carbon integrated Ø56	Alloy integrated Ø50	Alloy integrated Ø56
Blade	3K/UDM Carbon Weave	UDM Carbon Weave	UDM Carbon Weave	UDM Carbon Weave	UDM Carbon Weave	UDM Carbon Weave
Dropout	Carbon W/POST MOUNT	Carbon W/FLAT MOUNT	Mavic system	Carbon W/FLAT MOUNT	Carbon W/FLAT MOUNT	Carbon W/FLAT MOUNT
Offset	45mm/50mm	45mm/50mm	45mm/50mm	50mm	50mm	50mm



▲ FRC-614  
For BVR-095 frame,  
FM disc brake



▲ FRC-615  
700C full carbon  
1-1/8"~1.5"



▲ FRC-097  
for BVR-097 frame  
12\*100mm, flat  
mount disc brake



▲ FRC-619F  
20" fork with  
FM disc brake &  
V-brake

New



▲ FRC-621  
1-1/8" alloy  
steerer, N47 crown,  
PM disc brake



▲ FCC-610  
For BVC-096 frame,  
PM disc brake,  
12\*100mm through axle

New



▲ FCC-644  
gravel racing, FM disc  
brake, 12mm axle,  
internal cable routing



▲ FCC-725PMR  
Post mount disc brake,  
low rider bosses,  
N45 & N50mm



▲ FCC-705-15  
15mm through axle,  
1-1/8"~1.5" steerer



▲ FFC-034  
For BVF-157 frame,  
PM disc brake,  
15\*150mm through  
axle



▲ FMC-706  
650B carbon fork with  
post mount disc brake,  
15mm through axle



▲ FMC-704  
29er fork  
15mm through axle,  
1-1/8"~1.5" steerer

New



▶ BMA-2510  
Headset adjuster  
for 1" size



▶ BMA-2810  
Headset adjuster  
for 1-1/8" size



▶ TCC-103C-H30  
1-1/8", carbon top cap,  
L:30mm, OD: 23.2~24.2mm



▶ TCC-106-50  
1-1/8", alloy top  
cap, L:50mm,  
OD: 22~25mm

▶ Carbon spacer  
Carbon spacer in  
3,5,10,15,20mm height, for 1" & 1-1/8" size



▶ Carbon spacer CSC-34LT  
Light weight carbon spacer  
in 3,5,10,15,20mm height  
for 1" & 1-1/8"





CHENG YI ENTERPRISE CO., LTD.  
 TA HSIN CAR MATERIALS CO.  
 82-1, Puta Rd., Fengtes Tsun, Puyen  
 Hsiang, Changhua Hsien, Taiwan

The:886-04-8853182 · 886-04-8819072  
 Fax:886-04-8854832  
 E-mail : chengyi.a66@msa.hinet.net



DS-2094-PS    DS-2096    DS-2097    DS-2098    DS-304-81LL    DS-6108    DS-R17005



DS-R17007    DS-R17009    DS-R17011    DS-R18001    DS-R18002    DS-R18003    DS-356

**Fork Crowns**



**Handlebars**





**DS-MT1702 DS-M1703 DS-M1705 DS-M18102 DS-M18101 DS-M18103 DS-108314FK**



**DS-B007 DS-F1601 DS-B17003 DS-B17005 DS-M1706 DS-108010H DS-S17002**

**Handlebars**

**Stem**





research  
resell  
reserve  
reshape  
resilient  
resistant  
resolve  
resonate  
resort  
**resource**  
respect  
respond  
restack  
restage  
restart  
restate  
restore  
restring  
retag  
retail  
retouch  
retrain  
retrieve  
retrofit  
return  
reunify  
revitalize  
reveal  
revision  
revive  
rewind  
rework

# SOURCE

at *Interbike*

**SOURCE at Interbike** is a one-stop resource for importers, distributors, product managers and sourcing professionals to connect and source directly with manufacturers from around the world.

Interbike is the largest bicycle industry trade show in North America and is now the starting point for your OEM conversations.

**SOURCE at Interbike** is a new exhibit and meeting area dedicated to sourcing conversations between component and accessory manufacturers with product managers and distributors.

Manufacturers and suppliers that are specifically focused on securing OEM spec or international distribution are invited to be a part of **SOURCE at Interbike** and meet face-to-face with the extensive Interbike audience.

There is no better place or time to source for new suppliers and products and make the best buying decisions for your business.

**interbike**<sup>®</sup>  
MARKETWEEK

**Reno-Sparks Convention Center | Reno, NV**  
**September 18th – 20th**

[Interbike.com/source](http://Interbike.com/source)

# Specialized production of oil seals and boots for suspension forks.



252W6844



25.4" UPPER TUBE OIL SEAL



28" UPPER TUBE OIL SEAL



30" UPPER TUBE OIL SEAL



28.6" UPPER TUBE OIL SEAL



32" UPPER TUBE OIL SEAL



ISO 9001

絃 展

HUNG CHAN ENT.CO.,LTD.

No.3,Alley 46, Lane 256, Sec.4, Changshui Rd. Tungliao Li Hsihu Chen, Changhua Hsien 514, Taiwan.

Tel : 886-4-8823796 Fax: 886-4-8823798 E-mail:chan.ent@mas.hinet.net





**CWI**  
**4130FAN18**

- Electric MTB/29" Bike
- 1.5 inch Tapered
- Steerer tube:1-1/8"-1 1/2"
- Blade:Φ51 Alloy
- Weight:1080g



**CWI**  
**394FAN18**

- Electric MTB/29" Bike
- 1.5 inch Tapered
- Steerer tube:1-1/8"-1 1/2"
- Blade:Φ45 Alloy
- Weight:805g



**CWI**  
**73TFAN15**

- 29"/Fat Tire/Snow Bike
- OLD:150mm(15mm Axle)
- 1.5 inch Tapered
- Steerer tube:1-1/8"-1 1/2"
- Blade:Φ45 Alloy



**CWI**  
**232TFAN10**

- MTB/29"/Trail/Tandem Bike
- 1.5 inch Tapered
- Steerer tube:1-1/8"-1 1/2"
- Blade:Φ45 Alloy
- Dropout:Forged



**CWI**  
**232TFAN18**

- Electric/MTB/27.5"/29" Bike
- 1.5 inch Tapered
- Steerer tube:1-1/8"-1 1/2"
- Blade:Φ45 Alloy
- Dropout:15mm Axle



JIUN YIH INDUSTRIAL CO.,LTD.

## 2019 JIUN YIH

**SPECIALIZED IN FORK PRODUCTS**



**CWI**  
**794FAN18**

- 29"/Fat Tire/Snow Bike
- OLD:150mm(15mm Axle)
- 1.5 inch Tapered
- Steerer tube:1-1/8"-1 1/2"
- Blade:Φ45 Alloy

**NEW**



**CWI**  
**6130FAN24**

- Electric/27.5"/29" Bike
- 1.5 inch Tapered
- Steerer tube:1-1/8"-1 1/2"
- Blade:Φ51 Alloy
- Dropout:15mm Axle



**CWI**  
**4280FAN7**

- Electric/27.5"/29" Bike
- 1.5 inch Tapered
- Steerer tube:1-1/8"-1 1/2"
- Blade:Φ40 Alloy
- Dropout:Forged



**CWI**  
**232TFA9**

- MTB/29"/Trail/Tandem Bike
- 1.5 inch Tapered
- Steerer tube:1-1/8"-1 1/2"
- Blade:Φ45 Alloy
- Dropout:Forged



**CWI**  
**232TFAN21**

- Electric/MTB/27.5"/29" Bike
- 1.5 inch Tapered
- Steerer tube:1-1/8"-1 1/2"
- Blade:Φ45 Alloy
- Dropout:Forged



**CWI**  
**423TFAN15**

- 29"/Fat Tire/Snow Bike
- 1.5 inch Tapered
- Steerer tube:1-1/8"-1 1/2"
- Blade:Φ45 Alloy
- Dropout:15mm Axle



**CWI**  
**232TAN9S**

- Electric/MTB/29" Bike
- Steerer tube:1-1/8" Cr-Mo
- Blade:Φ45 Alloy
- Dropout:Forged



**CWI**  
**S718AN**

- Electric/City Bike
- Steerer tube:1-1/8" Cr-Mo
- Blade:Φ40 Alloy
- \*Welding
- Dropout:Forged



**CWI**  
**5120FAN21**

- Electric/MTB/27.5"/29" Bike
- 1.5 inch Tapered
- Steerer tube:1-1/8"-1 1/2"
- Blade:Φ45 Alloy
- Dropout:Forged



**CWI**  
**62TFAN15**

- Electric/Trekking Bike
- 1.5 inch Tapered
- Steerer tube:1-1/8"-1 1/2"
- Blade:Φ40 Alloy
- Dropout:15mm Axle

竣益工業股份有限公司  
JIUN YIH INDUSTRIAL CO.,LTD

No.66, Waipu Rd., Waipu Dist., Taichung City 438 Taiwan  
TEL: +886-4-26833696 FAX: +886-4-26833698 E-mail: cw188@ms27.hinet.net



**CWI**  
**725FA**

- City/28"/Electric Bike
- 1.5 inch Tapered
- \*Welding
- Steerer tube:1-1/8"-1 1/2"
- Blade:Φ40 Alloy



**CWI**  
**262TFAN9**

- City/Trekking Bike
- 1.5 inch Tapered
- Steerer tube:1-1/8"-1 1/2"
- Blade:Φ38 Alloy
- Dropout:Forged



**CWI**  
**614FAN25**

- City/26"/28" Bike
- 1.5 inch Tapered
- Steerer tube:1-1/8"-1 1/2"
- Blade:Φ38 Alloy
- Dropout:Forged



**CWI**  
**501FAN21**

- Electric/27.5"/29" Bike
- 1.5 inch Tapered
- Steerer tube:1-1/8"-1 1/2"
- Blade:Φ42 Alloy
- Dropout:Forged



**CWI**  
**3637FAN25**

- City/26"/28" Bike
- 1.5 inch Tapered
- Steerer tube:1-1/8"-1 1/2"
- Blade:Φ40 Alloy
- Dropout:Forged



**CWI**  
**4801FAN18**

- Electric/Trekking Bike
- 1.5 inch Tapered
- Steerer tube:1-1/8"-1 1/2"
- Blade:Φ40 Alloy
- Dropout:15mm Axle



**CWI**  
**3801FAN21**

- Electric/27.5"/29" Bike
- 1.5 inch Tapered
- Steerer tube:1-1/8"-1 1/2"
- Blade:Φ40 Alloy
- Dropout:Forged

**NEW**



**CWI**  
**606FAN24**

- Electric/City Bike
- 1.5 inch Tapered
- Steerer tube:1-1/8"-1 1/2"
- Blade:Φ38 Alloy
- Dropout:15mm Axle

**NEW**



**CWI**  
**620FAN18**

- Electric/City Bike
- 1.5 inch Tapered
- Steerer tube:1-1/8"-1 1/2"
- Blade:Φ48 Alloy
- Dropout:15mm Axle



**CWI**  
**E357FAN**

- Electric/City Bike
- 1.5 inch Tapered
- Steerer tube:1-1/8"-1 1/2"
- Blade:Φ31.8 Alloy
- Dropout:15mm Axle



JIUN YIH INDUSTRIAL CO.,LTD.

## 2019 JIUN YIH

**SPECIALIZED IN FORK PRODUCTS**

**NEW**



**CWI**  
**32TFA24**

- Electric/27.5"/29" Bike
- 1.5 inch Tapered
- Steerer tube:1-1/8"-1 1/2"
- Blade:Φ40 Alloy
- Dropout:15mm Axle



**CWI**  
**3801FAN18**

- Electric/27.5"/29" Bike
- 1.5 inch Tapered
- Steerer tube:1-1/8"-1 1/2"
- Blade:Φ40 Alloy
- Dropout:15mm Axle



**CWI**  
**606AN25**

- Electric/City Bike
- Steerer tube:1-1/8"
- Cr-Mo/Alloy
- Blade:Φ38 Alloy
- Dropout:Forged



**CWI**  
**307FAN24**

- Electric/29" Bike
- 1.5 inch Tapered
- Steerer tube:1-1/8"-1 1/2"
- Blade:Φ35 Alloy
- Dropout:15mm Axle

**NEW**



**CWI**  
**E627**

- MTB/27.5"/29" Bike
- Steerer tube:1-1/8"
- Cr-Mo
- Blade:Φ28.6 Cr-Mo
- Flat Mount



**CWI**  
**E658FAN**

- City/28" Bike
- 1.5 inch Tapered
- Steerer tube:1-1/8"-1 1/2"
- Blade:Φ31.8 Alloy
- Weight:580g

**NEW**



**CWI**  
**32TFAN14**

- Electric/27.5"/29" Bike
- 1.5 inch Tapered
- Steerer tube:1-1/8"-1 1/2"
- Blade:Φ40 Alloy
- Weight:725g



**CWI**  
**4180FAN18**

- Electric/City Bike
- 1.5 inch Tapered
- Steerer tube:1-1/8"-1 1/2"
- Blade:Φ40 Alloy
- Dropout:15mm Axle



**CWI**  
**2601TB**

- 29"/Fat Tire/Snow Bike
- OLD:135mm
- Steerer tube:1-1/8"
- Cr-Mo
- Blade:Φ33 Cr-Mo



**CWI**  
**262TFA9**

- City/Trekking Bike
- 1.5 inch Tapered
- Steerer tube:1-1/8"-1 1/2"
- Blade:Φ38 Alloy
- Dropout:Forged

竣益工業股份有限公司  
JIUN YIH INDUSTRIAL CO.,LTD

No.66, Waipu Rd., Waipu Dist., Taichung City 438 Taiwan  
TEL: +886-4-26833696 FAX: +886-4-26833698 E-mail: cw188@ms27.hinet.net



**CWI**  
**E3253N**

- MTB/27.5"/29" Bike
- Steerer tube:1-1/8"
- Cr-Mo
- Blade:Φ31.8 Cr-Mo
- Flat Mount



**CWI**  
**3263NH3**

- MTB/27.5"/29" Bike
- Steerer tube:1-1/8"
- Cr-Mo
- Blade:Φ28.6 Cr-Mo
- Flat Mount



**CWI**  
**3253NH2**

- MTB/27.5"/29" Bike
- Steerer tube:1-1/8"
- Cr-Mo
- Blade:Φ31.8 Cr-Mo
- Dropout:15mm Axle



**CWI**  
**3257N04**

- Electric/City Bike
- Steerer tube:1-1/8"
- Cr-Mo
- Blade:Φ31.8 Cr-Mo
- Dropout:S304



**CWI**  
**601BN**

- 27.5"/29" Bike
- Steerer tube:1-1/8"
- Cr-Mo
- Blade:Φ33 Cr-Mo
- Dropout:Forged



**CWI**  
**TA-IINH1**

- MTB/27.5"/29" Bike
- Steerer tube: 1-1/8"
- Cr-Mo
- Blade: Ø31.8 Cr-Mo
- Dropout: 15mm Axle



**CWI**  
**08224**

- Racing/Track Bike
- Steerer tube: 1" , 1-1/8"
- Cr-Mo
- Blade: Ø25.4 Cr-Mo
- Dropout: Forged

**NEW**



**CWI**  
**0803S2**

- MTB/27.5"/29" Bike
- Steerer tube: 1" , 1-1/8"
- Cr-Mo
- Blade: Ø25.4 Cr-Mo
- Dropout: Casting



**CWI**  
**08224N**

- Racing/Track Bike
- Steerer tube: 1" , 1-1/8"
- Cr-Mo
- Blade: Ø25.4 Cr-Mo
- Dropout: Forged



**CWI**  
**6257H3**

- Trekking/City Bike
- Steerer tube: 1-1/8"
- Cr-Mo
- Blade: Ø31.8 Cr-Mo
- Flat Mount



JIUN YIH INDUSTRIAL CO., LTD.

# 2019 JIUN YIH

**SPECIALIZED IN FORK PRODUCTS**



**CWI**  
**3257FH1**

- Electric/City/27.5"/29" Bike
- 1.5 inch Tapered
- Steerer tube: 1-1/8" - 1 1/2"
- Blade: Ø31.8 Cr-Mo
- Dropout: 15mm Axle



**CWI**  
**833H2**

- City/26"/28" Bike
- Steerer tube: 1" , 1-1/8"
- Cr-Mo
- Blade: Ø24 Cr-Mo
- Dropout: 15mm Axle



**CWI**  
**8C3S2**

- Trekking/City Bike
- Steerer tube: 1" , 1-1/8"
- Cr-Mo
- Blade: Ø25.4 Cr-Mo
- Dropout: Forged



**CWI**  
**0801S2**

- Racing/Track Bike
- Steerer tube: 1" , 1-1/8"
- Cr-Mo
- Blade: Ø24 Cr-Mo
- Dropout: Casting



**CWI**  
**819H3**

- Racing/650C Bike
- Steerer tube: 1" , 1-1/8"
- Cr-Mo
- Blade: Ø24 Cr-Mo
- Flat Mount



### CWI E0802

- Trekking/City/26" Bike
- Steerer tube: 1", 1-1/8"
- CrMo
- Blade: Φ24 Cr-Mo
- Flat Mount



### CWI 833H3

- Trekking/City/26" Bike
- Steerer tube: 1", 1-1/8"
- Cr-Mo
- Blade: Φ24 Cr-Mo
- Flat Mount



### CWI 2A1.70S2

- Racing/Track Bike
- Steerer tube: 1", 1-1/8"
- CrMo
- Blade: Φ24 Cr-Mo
- Dropout: Casting



### CWI 8A24H2

- City/700C Bike
- Steerer tube: 1", 1-1/8"
- CrMo
- Blade: Φ24 Cr-Mo
- Dropout: 15mm Axle



### CWI 0802S2

- Trekking/City/26" Bike
- Steerer tube: 1", 1-1/8"
- CrMo
- Blade: Φ24 Cr-Mo
- Dropout: Forged



### CWI H501

- Handlebar
- Cr-Mo 4130
- Heat Treatment



### CWI H601

- Handlebar
- Cr-Mo 4130
- Heat Treatment

竣益工業股份有限公司 No.66, Waipu Rd., Waipu Dist., Taichung City 438 Taiwan  
 JIUN YIH INDUSTRIAL CO.,LTD TEL: +886-4-26833696 FAX: +886-4-26833698 E-mail: cw188@ms27.hinet.net



### CWI 8A13H2

- MTB/City/700C/26" Bike
- Steerer tube: 1", 1-1/8"
- CrMo
- Blade: Φ24 Cr-Mo
- Dropout: 15mm Axle



### CWI 8C3H3

- Trekking/City/26" Bike
- Steerer tube: 1", 1-1/8"
- CrMo
- Blade: Φ25.4 Cr-Mo
- Flat Mount



### CWI 801H2

- Trekking/City/26" Bike
- Steerer tube: 1", 1-1/8"
- CrMo
- Blade: Φ24 Cr-Mo
- Dropout: 15mm Axle



### CWI 3506

- BMX 20mm Axle
- Steerer tube: C.N.C.
- Cr-Mo(4130)
- Blade: Φ31.8 Cr-Mo(4130)
- Heat Treatment



### CWI 3507

- BMX 20mm Axle
- Steerer tube: C.N.C.
- Cr-Mo(4130)
- Blade: Φ28.6 Cr-Mo(4130)
- Heat Treatment



### CWI 5501FA

- Racing
- Alloy/Alloy
- Blade: Φ40
- Heat Treatment



**KC-75165**

E-Bike / Trekking-Bike

**Steerer tube:** 1-1/2" Alloy

**Intergrated:** ø50mm, ø56mm

**Blade:** Alloy

**Optional:** Post mount . Flat mount  
ø12mm-15mm  
thru-axle



**KC-75167**

E-Bike / Trekking-Bike

**Steerer tube:** 1-1/2" Alloy

**Intergrated:** ø50mm, ø56mm

**Blade:** Alloy

**Optional:** Post mount . Flat mount  
ø12mm-15mm  
thru-axle



**KC-637403**

City/Trekking Fork

**Steerer Tube:** 1-1/8" & 1-1/2"  
Cr-Mo/Alloy

**Blade:** ø38.1 Alloy (7005)

**Optional:** Post mount/  
Iso mount



**KC-7448**

Alloy Cyclecross /  
Trekking Fork

**Steerer Tube:** 1-1/8" & 1-1/2" Alloy

**Blade:** ø38.1 Alloy (7005#)

**Optional:** Post mount /  
Iso mount  
15mm thru axle



**KC-A1301**

Alloy Cyclecross /Trekking  
Fork

**Steerer Tube:** 1-1/8" & 1-1/2"  
Cr-Mo/Alloy

**Blade:** Alloy (7005)

**Optional:** Post mount/  
Iso mount/  
Roller



**KC-13027**

City/Trekking/ 28" Fork

**Steerer Tube:** 1-1/8"-1-1/2"  
Cr-Mo/Alloy

**Blade:** Alloy (7005)

**Optional:** Post mount/  
Iso mount/  
Roller



**KC-P1302**

Alloy Cyclecross /  
Trekking Fork

**Steerer Tube:** 1-1/8" & 1-1/2"  
Cr-Mo/Alloy

**Blade:** Alloy (7005)

**Optional:** Post mount/  
Iso mount/  
Roller



**KC-9030-3C**

Alloy Cyclecross /  
Trekking Fork

**Steerer Tube:** 1-1/8" & 1-1/2" Alloy

**Blade:** ø40 Alloy (7005#)

**Optional:** Post mount /  
Iso mount  
15mm thru axle



**KC-1368**

Racing/650c/700c

**Steerer tube:** 1-1/8" & 1-1/2"  
Alloy

**Dropout:** Forged

**Intergrated:** ø52mm  
Alloy crown,  
Alloy blade



**KC-13257**

Racing/650c/700c

**Steerer tube:** 1-1/8" Cr-Mo/Alloy

**Intergrated:** ø45mm, ø50mm  
Alloy crown, Alloy  
blade

**Dropout:** Forged





### KC-28312

SPRING Fork

**Steerer tube:** 1" & 1-1/8" Cr-Mo  
**Blade:** Cr-Mo  
**Dropout:** Laser



### KC-300A

For Cruiser Fork

**Steerer tube:** 1 & 1-1/8" Cr-Mo/Alloy  
**Blade:** ø34.9mm, 38.1mm Cr-Mo/Alloy  
**Dropout:** Forged



### KC-14250C

For Cruiser fork

**Steerer tube:** 1" & 1-1/8" Cr-Mo  
**Blade:** Cr-Mo  
**Dropout:** Forged



### KC-6087A

Fat Bike

**Steerer tube:** 1-1/8" Stainless  
**Blade:** ø31.8 KVA STAINLESS MS3  
**Dropout:** Stainless



### KC-75353

City-Bike / Trekking-Bike

**Steerer tube:** 1" & 1-1/8" Cr-Mo  
**Blade:** Cr-Mo  
**Dropout:** ø12mm-15mm thru-axle

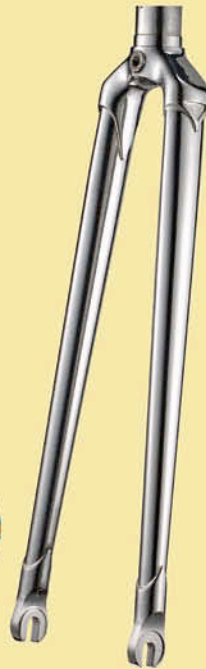

### KC-931

700c Road Bike

**Steerer tube:** 1" & 1-1/8" Seamless DB Reynolds 931 tubes  
**Dropout:** Stainless  
**Weight:** 780g



### HS-9834

Racing/650c/700c

**Steerer tube:** 1" & 1-1/8" Cr-Mo  
**Blade:** ø24Cr-Mo T/B  
**Dropout:** Casting



### HS-9825

Racing/650c/700c

**Steerer tube:** 1" Cr-Mo  
**Blade:** ø24Cr-Mo T/B  
**Dropout:** Casting



### HS-9821

Racing/650c/700c

**Steerer tube:** 1" Cr-Mo  
**Blade:** ø24Cr-Mo T/B  
**Dropout:** Casting







**HS-9950**

Racing/650c/700c

**Steerer tube:** 1" Cr-Mo  
**Blade:** ø24Cr-Mo T/B  
**Dropout:** Casting



**HS-9909**

Racing/650c/700c

**Steerer tube:** 1"&1-1/8" Cr-Mo  
**Blade:** ø25.4Cr-Mo T/B  
**Dropout:** Casting



**HS-99306**

Racing/650c/700c

**Steerer tube:** 1" Cr-Mo  
**Blade:** ø24Cr-Mo T/B  
**Dropout:** Casting



**HS-8798**

Racing/650c/700c

**Steerer tube:** 1" Cr-Mo  
**Blade:** ø24Cr-Mo T/B  
**Dropout:** Casting



**HS-8736**

Racing/650c/700c

**Steerer tube:** 1"&1-1/8" Cr-Mo  
**Blade:** ø28Cr-Mo T/B  
**Dropout:** Forged



**KC-5250**

Racing/650c/700c

**Steerer tube:** 1"&1-1/8" Cr-Mo  
**Blade:** Cr-Mo T/B  
**Dropout:** Forged



**HS-7260**

Racing/650c/700c

**Steerer tube:** 1"Cr-Mo  
**Blade:** ø24Cr-Mo T/B  
**Dropout:** Casting



**HS-7239**

Racing/650c/700c

**Steerer tube:** 1" Cr-Mo  
**Blade:** ø23Cr-Mo T/B  
**Dropout:** Forged



**KC-1361**

Racing/650c/700c

**Steerer tube:** 1-1/8" Cr-Mo/Alloy  
**Integrated:** ø45m/m, ø50m/m  
**Blade:** Alloy (7005)  
**Dropout:** Forged



**KC-1257**

Racing/650c/700c

**Steerer tube:** 1"&1-1/8" Cr-Mo  
**Blade:** ø25.4Cr-Mo T/B  
**Dropout:** Forged





鎧誠企業有限公司 KAI CHENG INDUSTRIAL CO., LTD.

TEL:886-4-8814651.8825305 FAX:886-4-8820612

516彰化縣埔鹽鄉豐澤村埔打路82-2號 E-mail:yy27@ms61.hinet.net



**KC-1258B**

Racing/650c/700c

**Steerer tube:** 1" & 1-1/8" Cr-Mo  
**Blade:** Cr-Mo T/B  
**Dropout:** Forged



**KC-13116**

Racing/650c/700c

**Steerer tube:** 1" & 1-1/8" Cr-Mo  
**Blade:** Cr-Mo(4130 T/B)  
**Dropout:** Casting



**KC-6025**

Racing/650c/700c

**Steerer tube:** 1" & 1-1/8" Cr-Mo  
**Blade:** Cr-Mo T/B  
**Dropout:** Casting



**KC-9976**

Racing/650c/700c

**Steerer tube:** 1" & 1-1/8" Cr-Mo  
**Blade:** ø24Cr-Mo T/B  
**Dropout:** Forged



**KC-9963**

Racing/Track Fork

**Steerer tube:** 1" & 1-1/8" Cr-Mo  
**Blade:** ø24Cr-Mo T/B  
**Dropout:** Forged



**KC-75352**

City-Bike / Trekking-Bike

**Steerer tube:** 1" & 1-1/8" Cr-Mo  
**Blade:** Cr-Mo  
**Dropout:** ø12mm-15mm thru-axle



**KC-74842**

City-Bike / Trekking-Bike

**Steerer tube:** 1" & 1-1/8" Cr-Mo  
**Blade:** Cr-Mo  
**Dropout:** Casting



**HS-1253SL**

City/Trekking Fork

**Steerer tube:** 1-1/8" Cr-Mo  
**Blade:** ø24Cr-Mo T/B  
**Dropout:** Cast End & Crown Stainless



**HS-1235D**

City/Trekking Fork

**Steerer tube:** 1" & 1-1/8" Cr-Mo  
**Blade:** ø24 Cr-Mo  
**Dropout:** M12 & M15 thru-axle



**HS-1225D**

City/Trekking Fork

**Steerer tube:** 1" & 1-1/8" Cr-Mo  
**Blade:** ø24 Cr-Mo  
**Dropout:** M12 & M15 thru-axle





### HS-1233SL

City/Trekking Fork

**Steerer tube:** 1" & 1-1/8" Cr-Mo

**Blade:** ø24Cr-Mo T/B

**Dropout:** Forged/Crown Stainless



### KC-9975

City/Trekking Fork

**Steerer tube:** 1" & 1-1/8" Cr-Mo

**Blade:** ø24Cr-Mo T/B

**Dropout:** Casting



### KC-6065

City/Trekking Fork

**Steerer tube:** 1" & 1-1/8" Cr-Mo

**Blade:** Cr-Mo T/B D-Type

**Intergrated OD:** Ø45mm, Ø50mm

**Dropout:** Forged



### KC-1237

City/Trekking Fork

**Steerer tube:** 1" & 1-1/8" Cr-Mo

**Blade:** Cr-Mo T/B

**Dropout:** Forged



### KC-14739B

City/Trekking Fork

**Steerer tube:** 1" & 1-1/8" Cr-Mo

**Blade:** ø31.8 Cr-Mo

**Dropout:** Forged



### KC-90303A

Fat Bike

**Steerer tube:** 1-1/8" & 1-1/2" / Cr-Mo/Alloy

**Blade:** ø35 Alloy (7005)

**Dropout:** Forged ø15mm thru axle

**Optional:** Post mount / Iso mount



### KC-9046

Alloy Cyclecross / Trekking Fork

**Steerer Tube:** 1-1/8" & 1-1/2" CR-MO

**Blade:** ø31.8CR-MO

**Dropout:** 15mm thru axle

**Optional:** Post mount / Iso mount



### KC-13031

MTB/26"/29" Fork

**Steerer tube:** 1-1/8" & 1-1/2" Cr-Mo

**Blade:** Cr-Mo (4130) T/B

**Dropout:** Forged



### KC-13090

MTB/26"/29" Fork

**Steerer tube:** 1-1/8" & 1-1/2" / Cr-Mo

**Blade:** ø31.8 Cr-Mo

**Dropout:** M15 thru-axle



### KC-13030

MTB/26"/29" Fork

**Steerer tube:** 1-1/8" & 1-1/2" / Cr-Mo

**Blade:** ø31.8 Cr-Mo

**Dropout:** M15 thru-axle





鎧誠企業有限公司 KAI CHENG INDUSTRIAL CO., LTD.

TEL:886-4-8814651.8825305 FAX:886-4-8820612

516彰化縣埔鹽鄉豐澤村埔打路82-2號 E-mail:yy27@ms61.hinet.net



**KC-13091**

MTB/26"/"29" Fork

**Steerer tube:** 1-1/8"Cr-Mo  
**Blade:** Cr-Mo (4130) T/B  
**Dropout:** Forged



**KC-13067**

MTB/26"/"29" Fork:

**Steerer Tube:** 1-1/8" & 1-1/2" Cr-Mo/Alloy  
**Blade:** Alloy (7005)  
**Dropout:** Forged  
**Optional:** Post mount/ Iso mount



**KC-500A**

MTB/Trail Fork

**Steerer tube:** 1-1/8"&1-1/2" Cr-Mo or Alloy  
**Blade:** Alloy (7005)  
**Dropout:** Forged



**KC-13015**

MTB/26"/"29" Fork

**Steerer Tube:** 1-1/8"&1-1/2" Cr-Mo/Alloy  
**Blade:** Alloy (7005)  
**Optional:** Post mount/ Iso mount



**KC-3424**

Jumping Fork

**Steerer tube:** C.N.C (4130)  
**Blade:** Cr-Mo (4130)  
**Dropout:** Laser (4130) Heat Treatment



**KC-116**

BMX Fork

**Steerer tube:** C.N.C (4130)  
**Blade:** Cr-Mo (4130)  
**Dropout:** Laser (4130) Heat Treatment



**KC-806**

BMX Fork

**Steerer tube:** C.N.C (4130)  
**Blade:** Cr-Mo (4130)  
**Dropout:** Laser (4130) & C.N.C Heat Treatment



**KC-801**

BMX Fork

**Steerer tube:** CNC (4130)  
**Blade:** Cr-Mo (4130)  
**Dropout:** Laser (4130) & CNC Heat Treatment



**K8**



**K20**



**K2**



**M16**

**MATERIAL:** Stainless Casting



**KC-13231**

Front/Rear, Quick release

**MATERIAL:** Stainless



**OS-E625D**  **ONE-PIECE DROPOUT DESIGN**

Steerer tube: 1 1/8"-1 1/2"  
Alloy(6061)

Blade: Ø50  
Wheel size: 29"  
Use: Electric bike  
Option: Pivot / Roller /  
IS mount /  
Post mount



**OS-E600D** **ONE-PIECE DROPOUT DESIGN**

Steerer tube :1 1/8"- 1 1/2"  
Alloy(6061)/

Blade: Ø50  
Wheel size: 700c  
Use: Trekking bike  
Option: Pivot / Roller /  
IS mount /  
Post mount



**OS-E650F**

Steerer tube : 1 1/8"  
Alloy(6061)  
Cr-Mo/Steel

Blade : Ø43  
Wheel size : 20"  
Use : Fording Bike  
Dropout : Forged  
Option : Flate mount



**OS-F642**

Steerer tube : 1 1/8"- 1/ 12"  
Alloy(6069)  
Cr-Mo/Steel

Blade : Ø56  
Wheel size : 700C  
Use : Electric Bike  
Dropout : Forged  
Option : Pivot / Roller  
IS mount /  
Post mont



**HOB-E625**

Steerer tube : 1 1/8" Cr-Mo  
Blade : Ø55

Wheel size : 26"  
Use : Electric Bike  
Dropout : Forged  
Option : Pivot / Roller  
IS mount /  
Post mont



**Liang Feng | Zhao Feng**

[www.lfzfmcl.com/](http://www.lfzfmcl.com/)

### OS-E455

Steerer tube : 1 1/8" - 1 1/2"  
Alloy(6061)/  
Cr-Mo/Steel

Blade: Ø50

Wheel size: 700c

Use: Trekking bike

/ Racing bike

Dropout : Forged

Options : Pivot / Roller /  
IS mount /  
Post mount



### OS-E410

Steerer tube : 1 1/8"  
Alloy(6061)/

Blade: Ø50

Wheel size: 700c

Use: / Racing bike

Dropout : Forged

Options : Pivot / Roller /  
IS mount /  
Post mount



www.lfzfmcl.com

### OS-E602

Steerer tube : 1 1/8" - 1 1/2"  
Alloy(6061)  
Cr-Mo/Steel

Blade : Ø43\*22

Wheel size : 700C

Use : Trekking bike

/ Racing Bike

Dropout : Forged

Option : Flate mount



### OS-E650

Steerer tube : 1 1/8"  
Alloy(6069)  
Cr-Mo/Steel

Blade : Ø48

Wheel size : 700C

Use : Trekking Bike

Dropout : Forged

Option : Pivot / Roller  
IS mount /  
Post mont



### OS-E542

Steerer tube : 1 1/8"  
Alloy(6061)/  
Cr-Mo/Steel

Blade: Ø50

Wheel size: 700c

Use: Trekking bike

Dropout : Forged

Weight : 742g

Options : Pivot / Roller /  
IS mount /  
Post mount



### OS-E757

Steerer tube: 1 1/8"-1 1/2"  
Alloy(6061)

Blade: Ø50 Alloy(6061)

Wheel size: 700C

Use: Electric bike

Dropout: Forged

Option: Pivot / Roller /  
IS mount /  
Post mount



### OS-E1205

Steerer tube: 1 1/8"-1 1/2"  
Alloy(6061)

Blade: Ø50 Alloy(6061)

Wheel size: 700C

Use: Fat Tire / Snow bike

Dropout: Forged

Option: Pivot / Roller /  
IS mount /  
Post mount



### OS-E410

Steerer tube : 1 1/8"  
Alloy(6061)/  
Cr-Mo/Steel

Blade: Ø50

Wheel size: 700c

Use: Racing bike

Dropout : Forged

Options : Pivot / Roller /  
IS mount /  
Post mount



## Liang Feng Zhao Feng

良豐機械股份有限公司  
LIANG FENG MACHINE CO., LTD.

地址: 43770 台中市大甲區東一街3號  
No.3, E. 1st St., Dajia Dist., Taichung City 437, Taiwan  
Tel : 886-4-26820629 Fax : 886-4-26820609  
E-mail : lfmc.chen@msa.hinet.net

昆山兆豐金屬制品有限公司  
KUNSHAN ZHAOFENG METAL PRODUCTS CO., LTD.

地址: 江蘇省昆山市玉山鎮玉城北路118號  
No. 118, Yucheng North Rd., Yushan Town, Kunshan City Jiangsu  
Tel : 86-512-57617989 Fax : 86-512-57617990  
E-mail : kszf\_888@163.com



Annual Innovation Products  
Competition Award Champion



**Morgana Carbon**

Super Light Air Spring Pressure  
Hydraulic Lockout  
26" 27.5" Crosscountry Carbon Fork  
Alloy 7050 Steerer  
CNC Alloy Carbon Crown  
30mm Alloy Tubes  
Carbon Magnesium Housing  
**W/ Post Disc Mount & Pivot**  
Travel: 80 or 100mm  
Option: Alloy Carbon Steerer  
Remote Hydraulic Lockout(RL)

FIT 3" TIRE



110mm

**110TA LO**

End width 110mm fit 3" Tire W/ Thru Axle  
Size: 27.5" 29" MTB Fork  
Steerer: Alloy Outer Leg: Alloy  
Crown: Alloy Forged (140mm)  
Stanchion: Alloy or Cr-mo OD.32mm  
**W/ Disc Mount; W/O Pivot; W/Thru Axle**  
Travel: 80, 100 or 120mm  
Option: Painting crown  
Model:110TA SA Single Preload  
Model:110TA MLA Lockout adjustable  
while riding on bike  
Model: 110TA LOA Remote Hydraulic Lockout

FIT 3" TIRE



110mm

**110EO LO**

End width 110mm fit 3" Tire W/ End Out  
Size: 27.5" 29" MTB Fork  
Steerer: Alloy Outer Leg: Alloy  
Crown: Alloy forged (140mm)  
Stanchion: Alloy or Cr-mo OD.32mm  
**W/ Disc M-ount; W/O Pivot**  
Travel: 80, 100 or 120mm  
Option: Painting crown  
Model:110EO SA Single Preload  
Model:110EO MLA Lockout adjustable  
while riding on bike  
Model:110EO LOA Remote Hydraulic Lockout



**T1 LOA**

Hydraulic Lockout  
26" 27.5" MTB Fork  
Alloy 7050 Steerer  
Black Alloy Forged Crown  
30mm Alloy Tubes  
Alloy Housing  
**W/ Post Disc Mount**  
Travel 80, 100 or 120mm  
Option: Pivot  
Painting Alloy Forged Crown  
Remote Hydraulic Lockout(RL)

Compression & Lockout



Preload



**Xcalibur SX**

Hydraulic Lockout  
Travel Change 80-140mm  
Adjustable Compression  
Adjustable Rebound  
26" 27.5" 29" Dirt-Jump Fork  
Cr-mo Steerer  
Painting Alloy Forged Crown  
32mm Alloy Tubes  
Alloy Housing  
**W/ Post Disc Mount;W/O Pivot**  
Option: Black Alloy Forged Crown



**Xcalibur SL**

Hydraulic Lockout  
Travel Change 80-140mm  
Adjustable Compression  
Adjustable Rebound  
26" 27.5" 29" Dirt-Jump Fork  
Cr-mo Steerer  
Black Alloy Forged Crown  
32mm Alloy Tubes  
Alloy Housing  
**W/ Post Disc Mount;W/O Pivot**



Alloy Remote Lockout Lever

**111 LO**

Option:Plastic Light Mount  
W/O Light , Lockout System  
26" 700C Electric Bike Fork  
Damper:(R)Oil & Nitrogen  
(L)Elastomer & Spring  
Alloy Forged Crown(112mm)  
28mm CP Stanchion W/ Seal  
Outer Leg:Alloy  
**W/Disc Mount & Pivot**  
Max.Travel:65mm



Model 111 SA Single Preload  
Model 111 E W/O Preload  
20" 26" 700C Electric Bike Fork  
Damper:Elastomer & Spring



**T401 LO**

Option: Disc Mount & Pivot  
Lockout System  
**18"-700C Trekking 4 Linkage Fork**  
Alloy or Cr-mo Stem  
Outer Leg: Alloy  
Damper: Oil & Nitrogen  
Travel: 45mm  
**Model T401 W/O Preload**  
Damper:Elastomer & Spring(MCU)

**Model: R405**

Racing 2 Linkage  
Suspension Fork  
20"26"700C Racing Fork  
Alloy or Cr-mo  
Outer Leg: Alloy  
**W/O Disc mount**  
Damping: Elastomer &  
Spring (MCU)  
Max Travel: 25mm

**T1 MLA-MEN**

Lockout Adjustable While  
Riding On Bike  
26" 27.5" MTB  
Damper: Elastomer & Spring  
Crown: Alloy Forged(125mm)  
Stanchion: Cr-mo or anodized tubes  
Look as Alloy(30mm)  
Outer Leg: Alloy  
**W/ Post Disc Mount; Option:Pivot**  
Max.Travel:80 or 100mm  
**Model T1 LO- MEN Lockout System**  
**Model T1 SA- MEN Single Preload**  
**Model T1 E- MEN W/O Preload**

**079LO-MEN**

Lockout System  
26" 27.5" MTB  
Damper: (R)Oil & Nitrogen;  
(L)Elastomer & Spring  
Crown: Alloy Forged(125mm)  
Stanchion: Cr-mo (30mm)  
Outer Leg: Alloy  
**W/ Post Disc Mount; Option:Pivot**  
Max.Travel:80 or 100mm  
**Model 079MLA-MEN**  
Lockout Adjustable While Riding On Bike  
**Model 079SA Single Preload**  
**Model 079E W/O Preload**

**AC605 Carbon**

700C Trekking Carbon Fork  
Alloy 7050 Steerer  
Carbon Alloy Housing  
Blades' Tire Width: 72mm  
Option: Pivot or Disc Mount

**A306 FAT**

26"Fat / Snow/ Beach Fork  
Stem: 1 1/8" Hi-ten or Cr-mo  
Crown:Alloy  
**W/ Disc Brake Mount; W/O Pivot**  
End:Forged For 135mm Hub  
Option:Raw or Painting



**T2LO-MEN / T3LO-MEN / T5LO-MEN**

Lockout System  
26" 27.5" MTB  
Damper:(R)Oil & Nitrogen; (L)Elastomer & Spring  
Crown: Alloy Forged(125mm)  
Stanchion: Cr-mo (28mm)  
Outer Leg: Alloy  
**W/ Post Disc Mount; W/O Pivot**  
Max.Travel: 80 or 100mm  
**Model T2 MLA/ T3 MLA/ T5 MLA**  
Lockout Adjustable While Riding On Bike  
**Model T2SA/ T3SA/ T5SA Single Preload**  
**Model T2E/ T2E/ T5E W/O Preload**

**T8 LOA**

Spindie Quick Release Ø15  
Lockout System  
27.5"MTB Fork  
Damper:(R)Oil & Nitrogen; (L)Elastomer & Spring  
Painting Alloy Forged Crown(128mm)  
32mm Alloy Stanchion W/Seal  
Option:Cr-mo Stanchion (OD. 30mm)or  
Anodized Tubes Look as Alloy  
Outer Leg: Alloy  
**W/ Post Disc Mount; W/O Pivot**  
Max.Travel: 80 or 100mm  
For 100mm Hub

**T7 LOA**

Normal Ende 10mm

**T9LOA**

Spindie Quick Release Ø15  
Lockout System  
26"Fat/ Snow / Beach Fork  
Damper: (R)Oil & Nitrogen; (L)Elastomer & Spring  
Painting Alloy Forged Crown(172mm)  
32mm Alloy Stanchion W/Seal  
Option:Cr-mo Stanchion (OD.30mm) or Anodized  
Tubes Look as Alloy  
Outer Leg: Alloy  
**W/ Post Disc Mount; W/O Pivot**  
Max.Travel: 90mm  
For 135mm Hub

**T10LOA**

Normal Ende 10mm



# PERFORMANCE & VALUE ENGINEERED TO FIT



STANCE MGX



STANCE MGV



STANCE ALV



VALOR-RL



VALOR-LO



TRAVERSE-LO

MODEL	WHEEL SIZE	TRAVEL	DROPOUT	LOWER LEG MATERIAL	STANCHION MATERIAL	STEERER MATERIAL	PRELOAD	REBOUND	LOCKOUT	REMOTE LOCKOUT
STANCE MGX	27.5"	100/120mm	9	MAGNESIUM	ALUMINUM	STEEL	STEEL	STEEL	YES	OPTIONAL
STANCE MGV		80/100/120mm			ALUMINUM					OPTIONAL
STANCE ALV		80/100mm		ALUMINUM	STEEL					NO
VALOR-RL	26"	80/100mm								YES
VALOR-LO										NO
TRAVERSE-LO	700C	50/65mm								NO



M1-FC4



M1-FC5

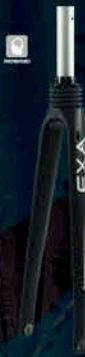

M1-FC6



M1-FC7



M1-FA11



S4-FA8

MODEL	USE	WHEEL SIZE	SPRING TYPE	TRAVEL	DAMPER	BRAKE MOUNT	BLADE MATERIAL	STEERER MATERIAL	COLOR	WEIGHT	PATENTS
M1-FC4	ROAD	700C	INTERNAL COIL	15mm	FRICTION	CALIPER	CARBON FIBER	6066/G609 ALLOY	BLACK/WHITE/CUSTOM	723g	TAIWAN/CHINA
M1-FC5	CYCLO-CROSS					POST-TYPE				793g	
M1-FC6	ROAD					VIS/CALIPER				769g	
M1-FC7	CYCLO-CROSS					VIS/ROLLER/CALIPER				1013g	
M1-FA11	CITY BIKE/TREKKING					6061 ALLOY				1047g	
S4-FA8	CITY BIKE/TREKKING	20"/24"/26"/28"/700C	28mm	6061 ALLOY	11A	1410g	N/A				



凱薩克科技股份有限公司  
KIND SHOCK HI-TECH CO., LTD.  
NO.72,KUNG MING SOUTH 1st ROAD  
AN-NAN DISTRICT TAINAN CITY  
TAIWAN, R.O.C.  
台南市安南區工明南一路72號  
電話 (TEL): 886-6-2568575  
傳真 (FAX): 886-6-2567293  
kssale@kindshockglobal.com

東莞元渝機械有限公司  
DONGGUAN YENYUE MACHINERY CO.,LTD.  
NO.62 KIRIN RIDGE ROAD, SHAHU VILLAGE,  
TAN CXIA TOWN, DONGGUAN CITY  
東莞市塘夏鎮沙湖村麒麟嶺路62號  
電話 (TEL): 86-769-86852366  
傳真 (FAX): 86-769-86852388  
yueyen@kindshock.com.cn

凱薩克機械(太倉)有限公司  
KINDSHOCK INDUSTRIES (TAICANG) CO., LTD.  
LIENDA INDUSTRY COMMUNITY, LUDU TOWN  
TAICANG CITY, JIANGSN PROVINCE  
江蘇省太倉市陸渡鎮飛龍北路聯達工業區內  
電話 (TEL): 0512-53456575/6  
傳真 (FAX): 0512-53456577  
kindshock@21.cn.com

WWW.EXA-FORM.COM



**Model: LAC67BJJ5223**  
 Type: 700C Trekking  
 Material: #6061  
 Steerer tube:1-1/8"



**Model: LAC679FQ5922**  
 Type: 700C Trekking  
 Material: #6061  
 Steerer tube:1-1/8" -1-1/2"  
 Blade:Oil Cast One Piece



**Model: LAR679FQ5962**  
 Type: 700C Racing  
 Material: #6061/CR-MO  
 Steerer tube:1-1/8" -1-1/2"  
 Dropout:Post Mount  
 Blade:Oil Cast One Piece



**Model: LAR679FQ5747**  
 Type: 700C Racing  
 Material: #6061/CR-MO  
 Steerer tube:1-1/8" -1-1/2"  
 Blade:Oil Cast One Piece



**Model: LAC679FQ5940**  
 Type: 700C Racing  
 Material: #6061  
 Steerer tube:1-1/8" -1-1/2"  
 Blade:Oil Cast One Piece



**Model: LAC699HC**  
 TYPE:700C TREKKING  
 MATERIAL: #6061  
 STEM:28.6mm \* 22.2mm  
 INTEGRATED: N50mm



**Model: LAC692HA**  
 TYPE:700C TREKKING  
 MATERIAL: #6061  
 STEM:28.6mm \* 25.4mm(cr-mo)  
 INTEGRATED:N58mm (1.5")



**Model: LAC679JC**  
 TYPE:700C TREKKING  
 MATERIAL: #6061  
 STEM:28.6mm \* 22.2mm  
 INTEGRATED: N50mm



**Model: LAC392HA-D41**  
 TYPE: 26" ALL-TERRAIN  
 MATERIAL: #6061  
 OFFSRT:43mm  
 TIRE CLEARANCE: 26 x 4.8"  
 (on rims up to 100mm wide)



## SUSPENSION FORKS



Full carbon/hybrid carbon alloy suspension forks

AL7050 hard anodized stanchions, 30~34mm

Oil damping system with adjustable rebound, lockout and compression

Configurable axle and travel options

Hub spacing: 100/110/135/150mm

20"/24"/26"/650b/29"/650b+/29+

Fatbike suspension forks for tires up to 5.0"

Full carbon/hybrid carbon alloy rigid forks

Configurable axle, steerer tube and brake mount options

AC up to 490mm

Hub spacing: 100/110mm

20"/24"/26"/650b/29"/650b+/29+



## MTB RIGID FORKS

MEKKEM INDUSTRIAL INC.

Taichung City, Shengang District  
No. 80, Ln. 524, Hemu Rd. Sec. 1  
42953 Taiwan

Tel: +886 4 2561 1016

Fax: +886 4 2561 1017

Email: meks.mekkem@msa.hinet.net

Url: www.mekkem-parts.com

## BOTTLECAGES

Full carbon  
Light weight (8gr.up)  
Customisable design



Side load cages  
Suitable for full suspension frames

## HANDLEBARS

**XC** Full HM carbon light weight MTB bars  
MAX width up to 760mm  
No rider weight limit  
Wide range geometry options



**GRAVITY** Full HM carbon DH/All mountain bars  
Max width up to 850mm  
No rider weight limit  
Wide range geometry options  
Bar center: 31.8mm/35mm

Various light weight accessories available  
seat clamps, derailleur clamps, stems, etc, ...



## ACCESSORIES



Full HM carbon light weight seatposts  
Wide application range: MTB, road,  
foldable, etc, ...  
Length up to 580mm  
OD: 25.4/27.2/30.9/31.6/34.9  
Offset: 0~25mm

## SEATPOSTS



# Redefining Limits

**NEW**



**REBEL**

CATEGORY	29" & 27.5+
CROWN PITCH	140 mm
STANCHION	32mm 7050 Aluminum Hard Anodize Black
CASTING	Magnesium 20mm Boost Thru Bolt Axle (Optional 15x110 Thru Bolt Axle)
FEATURE	Hydraulic Compression, Rebound adjust, Air Spring
TRAVEL(mm)	29": 80, 100, 130mm 27.5+: 100, 130, 140, 150mm

**NEW**



**STEM SHOCK**

NA
NA
NA
Fits into a regular 1-1/8" inch steerer
Angle adjust spacer option for the stem
20mm

**NEW**



**ELEV8 E**

NA
NA
NA
Electronic Height Adjustment Seat Post
Electronic Remote Operated
100, 125, 150mm

**RST**





**KILLAH**

CATEGORY	29"
CROWN PITCH	145 mm-Dual
STANCHION	38mm 7050 Aluminum Hard Anodize Black
CASTING	Magnesium 20x110mm Boost Thru Bolt Axle
FEATURE	Hydraulic Compression, Rebound adjust
TRAVEL(mm)	200 mm



**STITCH**

CATEGORY	29"
CROWN PITCH	145 mm
STANCHION	38mm 7050 Aluminum Hard Anodize Black
CASTING	Magnesium 20mm Boost Thru Bolt Axle (Optional 15x110 Thru Bolt Axle)
FEATURE	Hydraulic Compression, Rebound adjust, Air Spring
TRAVEL(mm)	160, 170, 180 mm



**NEW E-MTB**

COMING SOON

CATEGORY	29" & 27.5+
CROWN PITCH	150 mm
STANCHION	34mm Steel QPQ Black
CASTING	Magnesium 15x110mm Thru Bolt Axle
FEATURE	Hydraulic Lock-Out
TRAVEL(mm)	29" / 27.5+: 100, 120, 130, 140 mm



**ALPHA 110-15 RA**

CATEGORY	29" & 27.5+
CROWN PITCH	140 mm
STANCHION	32mm Steel Ti Color
CASTING	Magnesium 15x110mm Thru Bolt Axle
FEATURE	Hydraulic Rebound adjust
TRAVEL(mm)	29" / 27.5+: 80, 100, 120, 130, 135 mm



**BLAZE 110-15**

CATEGORY	29" & 27.5+
CROWN PITCH	
STANCHION	30mm Steel QPQ Black
CASTING	Aluminum 15x110mm Thru Bolt Axle
FEATURE	Hydraulic Lock-Out
TRAVEL(mm)	29" / 27.5+: 100, 120, 130 mm



**AERIAL 29-15**

CATEGORY	29"
CROWN PITCH	130mm
STANCHION	32mm Steel QPQ Black
CASTING	Magnesium 15mm QR
FEATURE	Hydraulic Lock-out, Air Spring
TRAVEL(mm)	80, 100, 120 mm



**CAPA 29 & 27.5**

CATEGORY	29" & 27.5"
CROWN PITCH	130mm
STANCHION	25.4mm Steel CP Finish
CASTING	Aluminum 9mm Open Dropout
FEATURE	Mechanical Lock-Out
TRAVEL(mm)	29" / 27.5: 60, 80 mm



**PULSE 27.5-15**

CATEGORY	27.5"
CROWN PITCH	130mm
STANCHION	30mm Steel QPQ Black
CASTING	Magnesium 15mm QR
FEATURE	Hydraulic Lock-out, Air Spring
TRAVEL(mm)	60, 80, 100 mm

E-BIKE



**VOGUE E**

CATEGORY	700C
CROWN PITCH	130 mm
STANCHION	30mm 7050 Aluminum Hard Anodize Black
CASTING	Aluminum 9mm Open Dropout
FEATURE	Hydraulic Compression, Rebound adjust, Lock-out, Air Spring
TRAVEL(mm)	50, 60, 80 mm

E-BIKE



**VIVAIR E**

CATEGORY	700C
CROWN PITCH	130mm
STANCHION	30mm Steel QPQ Black
CASTING	Aluminum 9mm Open Dropout
FEATURE	Hydraulic Lock-out, Air Spring
TRAVEL(mm)	50, 60, 80 mm

E-BIKE



**VOLANT E**

CATEGORY	700C
CROWN PITCH	130mm
STANCHION	30mm Steel CP Finish
CASTING	Aluminum 9mm Open Dropout
FEATURE	Hydraulic Lock-out,
TRAVEL(mm)	50, 60, 80 mm

E-BIKE



**A7**

CATEGORY	700C
CROWN PITCH	NA
STANCHION	NA
CASTING	Aluminum 9mm Open Dropout
FEATURE	Alu. Blade
TRAVEL(mm)	30, 35mm

# Suspension fork line-up 2019



Model	RUX38-Boost	DUROLUX36 Boost	DUROLUX	AURON35 Boost
Intended use	Downhill	All Mountain	All Mountain	All Mountain
	eMTB	eMTB	eMTB	eMTB
Wheel size	27.5"	29x2.6"	27.5"	29x2.4"/27.5x2.8"
Travel (mm)	200	160 / 170 /180	160/170/180	130/140/150/160
Damping	R2C2-PCS/RC2-PCS	R2C2-PCS/RC2-PCS	R2C2-PCS/RC2-PCS/RC	RC2-PCS
Spring	Air	Air	Air	Air
Brake mount	Post	Post	Post	Post

Classification of products and bike riding styles eMTB:eBike (E45) Track: Smooth off-road, Stone paved road, Paved road,Specified products are valid on motorized assist up to 45 km/h.  
eBike (E25) Track: Stone paved road, Paved road,Specified products are valid on motorized assist up to 25 km/h.



Model	AURON	AION35 Boost	AION	ZERON35 Boost
Intended use	Trail	All Mountain	Trail	All Mountain
	eMTB	eMTB	eMTB	eMTB
Wheel size	29"/27.5"	29x2.4"/27.5x2.8"	29"/27.5"	29x2.4"/27.5x2.8"
Travel (mm)	29": 130/140/150 27.5": 150/160	29": 120/130/140/150 27.5": 130/140/150/160	29": 130/140 27.5": 130/140/150/160	130/140/150
Damping	RLRC-PCS/LORC-PCS/RC2-PCS	RC-PCS/RC/RLR/LOR	RC/RLR/LOR	RLR/LOR
Spring	Air	Air	Air	Coil
Brake mount	Post	Post	Post	Post

Classification of products and bike riding styles Cross Track: Paved road, Smooth off-road  
Trekking Track: Paved road, Smooth off-road  
City/Urban Track: Paved road  
Casual MTB Track: Paved road, Smooth off-road



www.srsuntour-cycling.com

TAIWAN  
SR Suntour Inc.  
#7 Hsing Yeh Rd  
Fu Hsing Industrial Zone  
ChangHua 506  
Tel. +886-4-7695115  
Fax +886-4-7694028

CHINA  
SR Suntour (ShenZhen) Inc.  
Suibei Industrial Zone Subei Rd  
Gongming Town, Guangming District  
ShenZhen China  
Tel. +86-755-27105533  
Fax +86-755-27105633

CHINA  
SR Suntour Machinery Inc.  
1500 Honghu Rd, PengLang,  
KunShan Development Zone  
JiangSu Province China 215333  
Tel. +86-512-5518-8088  
Fax +86-512-5517-1117

VIETNAM  
SR SUNTOUR VIETNAM CO., LTD  
Lot. 17-8, Street 3B,  
Protrade International Tech Park,  
An Tay commune, Ben Cat Town,  
Binh Duong Province, Viet nam.  
Tel: +84-274-3721-883



Model	AXON34 Boost	AXON32 Boost	RAIDON34 Boost	RAIDON32 Boost	XCR34 Boost
Intended use	XC	XC	XC	XC	XC
	eMTB	eMTB	eMTB	eMTB	eMTB
Wheel size	29x2.4"/27.5x2.6"	29x2.4"/27.5x2.6"	29x2.4"/27.5x2.6"	29x2.4"/27.5x2.6"	29x2.4"/27.5x2.6"
Travel (mm)	120/130	29": 80/100 27.5": 100/120	29": 100/120/130 27.5": 120/130	29": 80/100 27.5": 100/120	29": 100/120/130 27.5": 120/130
Damping	RLRC-PCS/LORC-PCS	RLRC/LORC	RLR/LOR	RLR/LOR	RLR/LOR/RL/LO
Spring	Air	Air	Air	Air	Air/Coil
Brake mount	Post	Post	Post	Post	Post

Classification of products and bike riding styles eMTB:eBike (E45) Track: Smooth off-road, Stone paved road, Paved road, Specified products are valid on motorized assist up to 45 km/h.  
eBike (E25) Track: Stone paved road, Paved road, Specified products are valid on motorized assist up to 25 km/h.



Model	XCR32 Boost	XCM34 Boost	XCM32 Boost	XCM ATB	XCT ATB
Intended use	XC	Casual MTB	Casual MTB	Casual MTB	Casual MTB
	eMTB	eMTB	eMTB	-	-
Wheel size	29x2.4"/27.5x2.6"	29x2.4"/27.5x2.8"	29x2.4"/27.5x2.8"	29x2.4"/27.5x2.4"	29x2.4"/27.5x2.4"
Travel (mm)	29": 80/100 27.5": 100/120	100/120/130	80/100/120	80/100	80/100
Damping	RLR/LOR/RL/LO	LOR/RL/LO/HLO	LOR/RL/LO/HLO	RL/LO/HLO	HLO
Spring	Air/Coil	Coil	Coil	Coil	Coil
Brake mount	Post	Post	Post	Post	Post

Classification of products and bike riding styles Cross Track: Paved road, Smooth off-road  
Trekking Track: Paved road, Smooth off-road  
City/Urban Track: Paved road  
Casual MTB Track: Paved road, Smooth off-road



www.srsuntour-cycling.com

TAIWAN  
SR Suntour Inc.  
#7 Hsing Yeh Rd  
Fu Hsing Industrial Zone  
ChangHua 506  
Tel. +886-4-7695115  
Fax +886-4-7694028

CHINA  
SR Suntour (ShenZhen) Inc.  
Suibei Industrial Zone Subei Rd  
Gongming Town, Guangming District  
ShenZhen China  
Tel. +86-755-27105533  
Fax +86-755-27105633

CHINA  
SR Suntour Machinery Inc.  
1500 Honghu Rd, PengLang,  
KunShan Development Zone  
JiangSu Province China 215333  
Tel. +86-512-5518-8088  
Fax +86-512-5517-1117

VIETNAM  
SR SUNTOUR VIETNAM CO., LTD  
Lot. 17-8, Street 3B,  
Protrade International Tech Park,  
An Tay commune, Ben Cat Town,  
Binh Duong Province, Viet nam.  
Tel: +84-274-3721-883



# Suspension fork line-up 2019



Model	XCT30	XCE28	XCM32-CG	MOBIE45
Intended use	Casual MTB	Casual MTB	Cargo Bike	-
Wheel size	29"/27.5"	29"/27.5"/26"	20x2.15"	eBIKE-E45
Travel (mm)	80/100	80/100	70	60/80/100
Damping	HLO	-	HD	RLR/LOR
Spring	Coil	Coil	Coil	Air/Coil
Brake mount	Post	Post/V-brake	Post	Post

Classification of products and bike riding styles eMTB:eBike (E45) Track: Smooth off-road, Stone paved road, Paved road, Specified products are valid on motorized assist up to 45 km/h.  
eBike (E25) Track: Stone paved road, Paved road, Specified products are valid on motorized assist up to 25 km/h.



Model	MOBIE25	MOBIE A32	NEX E25	CR85 E25
Intended use	eBike-E25	eBike-E25	Trekking	City
Wheel size	700C/27.5"	27.5"	700C	700C
Travel (mm)	63/75/100	63/75	50/63/75	Roller:40 V-brake:50/63
Damping	RLR/LOR	RL/LO	LO/HLO	LO
Spring	Air/Coil	Coil	Coil	Coil
Brake mount	Post	Post	Post/V-brake	Roller/V-brake

Classification of products and bike riding styles Cross Track: Paved road, Smooth off-road  
Trekking Track: Paved road, Smooth off-road  
City/Urban Track: Paved road  
Casual MTB Track: Paved road, Smooth off-road



www.srsuntour-cycling.com

TAIWAN  
SR Suntour Inc.  
#7 Hsing Yeh Rd  
Fu Hsing Industrial Zone  
ChangHua 506  
Tel. +886-4-7695115  
Fax +886-4-7694028

CHINA  
SR Suntour (ShenZhen) Inc.  
Suibei Industrial Zone Subei Rd  
Gongming Town, Guangming District  
ShenZhen China  
Tel. +86-755-27105533  
Fax +86-755-27105633

CHINA  
SR Suntour Machinery Inc.  
1500 Honghu Rd, PengLang,  
KunShan Development Zone  
JiangSu Province China 215333  
Tel. +86-512-5518-8088  
Fax +86-512-5517-1117

VIETNAM  
SR SUNTOUR VIETNAM CO., LTD  
Lot. 17-8, Street 3B,  
Protrade International Tech Park,  
An Tay commune, Ben Cat Town,  
Binh Duong Province, Viet nam.  
Tel: +84-274-3721-883



品賦實業股份有限公司

P.F. PIN FU CORPORATION

聯絡人：業務經理 潘佳成

Contact : Peter Pan

Email : peter@pinfu.tw

Skype : peter7952544

地址：臺灣台南市安定區管寮里24-14號

Add : No. 24-14, Guanliao Village, Anting Dist.,

Tainan 74548, Taiwan

Tel : 886-6-5923401 Fax : 886-6-5920610

http://www.gaslift.com.tw

http://www.氣壓棒.台灣

Email : peter@pinfu.tw

20 years Production Experience  
Made in Taiwan. Quality Guarantee.

German standard DIN 4550-3,-4 certificates were accredited by TUV.



### Seat post cartridges

- 油氣混合 Oil and air mix system
- 油氣分離 Oil and air individual system
- 油氣分離抗壓式 Oil and air individual system(Off-road)

### Suspension fork cartridges

- 純氣壓棒 Air spring for Trekking bike, comfortable bike
- 純油壓棒 Hydraulic system for MTB
- 油氣混合 Oil and air mix system for XC
- 油氣分離 Oil and air individual system for XC, DH
- 油氣分離抗壓式 Oil and air individual system(Off-road) for Freeride, DH
- 回彈阻尼可調 Suitable for DH, long travel, rebound damper adjustable



### TF-7519

For 700C  
Material: Cr-mo  
Crown. end:  
Investment casting



### TF-2018

Hub Axle 150mm  
Alloy  
Stem: 1.1"  
Head parts. 39.8mm



### TF-7588

Down Hill  
Material: Steel, Cr-mo



### TF-2000F

For Fat bike, Snow bike  
Material: Cr-mo, Steel  
hub Ø 135mm



### TF-70X

Alloy



### TF-880

For MTB Suspension.  
Crown: Steel, Alloy  
Brace: Steel.  
Blade: Steel.



### TF-607

700 Alloy



### TF-2000

Classical and stylish design  
For cruiser with suspension  
Pivot is optional  
Compatible with disk brakes  
Finish: CP or paint  
Different size available



### TF-2011

Material: Steel, Cr-Mo  
Stem: 1 1/8  
For 700C, Fixed

#### TF-2011-1



### TF-0435

700C  
Material: Alloy, Cr-Mo  
For City bike



### TF-7518

Material: Cr-Mo  
Lost Wax Casting  
end, Fork crowns  
Stem: 1"  
700C



### TF-6060

For MTB/Trekking bike  
Material: Alloy  
Investment  
Casting Disc  
Brake



### TF-7589

Down Hill  
Material: Steel Cr-mo



### TF-102

For 700C, Racing  
D-shaped tube  
Material: Cr-mo,  
Steel



# WULER®

WULER Bicycle Ind. Co., Ltd.

Factory 1 No. 720, Wen-Chu Rd., Dajia Dist., Taichung City, Taiwan

Factory 2 No.460, Sec. 1, Zhongshan Rd., Dajia Dist., Taichung City 437, Taiwan

T +886-4-26860963

F +886-4-26882436

E wuler@ms27.hinet.net

[www.wuler.com.tw](http://www.wuler.com.tw)

BMX  
MTB  
UNICYCLE  
CARGO  
FATBIKE

CURISER  
OTHERS

CITY  
TREKKING  
RACING  
700C  
CYCLOCROSS  
FIXIE  
GRAVEL





裕 順



# YOU SHUN INDUSTRIAL CORP. LTD.

No.4-6, Lane1, Hao Chin RD, Pu Yen Hsien  
Changhua Hsieng Taiwan

Tel:886-4-8818612 Fax:886-4-8815371

Email:youshun@ms61.hinet.net

www.youshun.com.tw

skype:youshun-jacky



www.youshun.com.tw



GK-401FK



GK-409FK



GK-3001FK



YS-3004FK



YS-1220FK



GK-3000RC



YS-6550RC



YS-1228RC



GK-3015RC



YS-5010RC



YS-420FD



YS-2150MM



3D Print/RP



Fatigue testing machine



Impact testing machine



Hardness testing machine



Laser engraving machine

KING WAY IS CUSTOMIZE  
客製化才是王道



www.youshun.com.tw



YS-9317DJ



YS-1905DJ



YS-5805MB



YS-5230MB



GK-1020FB



YS-300DH



YS-860RD



YS-833RD



YS-870RD



YS-453DH



YS-454DJ



YS-851RD



YS-810ST



YS-8250RD



GK-736SPD



UNIQUE IS KING WAY  
無可取代才是精品



GK-401HB



GK-402HB



GK-501HB



GK-503HB



GK-504HB



YS-1014HB



GK-507HB



YS-7230HB



YS-8400HB

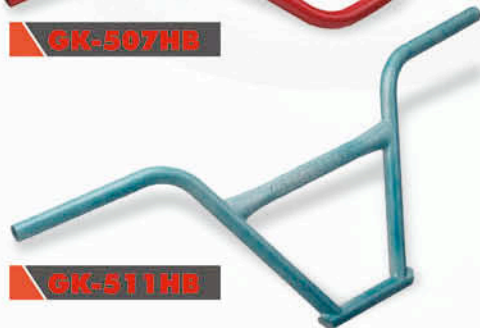

GK-511HB



YS-7365HB



YS-621HB

## Crowns



## Front Fork Stem

One Piece CNC  
And Fluted



One Piece CNC  
Spiral Tube

## Tube System

我們提供各類型前叉管件更彈性的搭配選擇  
We offer all kinds of front fork pipe with more flexible options

	GENERAL TUBE			FLUTED TUBE	
	SPIRAL TUBE			INNER AND OUTER SPIRAL TUBE	
	"X" TUBE			INNER AND OUTER FLUTED TUBE	



深圳市摩大科技有限公司  
SHEZNEHN MOZO TECHNOLOGY CO.,LTD

ADD: 深圳市光明新区公明民生工业城121栋  
Tel: 86-755-2969-4455  
Fax: 86-755-8173-8055  
Http: //www.mozo.bike  
E-mail: sales@usamozo.com

天津市摩大金属制品有限公司  
TIANJIN MOZO METALWORK CO.,LTD

ADD: 天津市北辰区双口镇工业园区宏光路6号  
Tel: 86-22-2695-5128  
Fax: 86-22-2695-6055  
Http: //www.mozo.bike  
E-mail: cn@usamozo.com



**NM-300**

(FAT BIKE)  
26" 24" 20"  
Coil spring  
Forged Alloy Dropout  
Disc Brake  
Steel crown  
38mm hi-ten Stanchions  
31.8mm hi-ten lowers  
For 4.0" (135mm)



**FT-40**

26" 24" 20"(FATBIKE)  
Pitch 130mm(4.0" 135mm)  
Adjustable Preload  
Spring Pressure System  
Hydraulic Lock-out  
Remote Lock-out  
Air Spring  
Forged Alloy Crown  
C 38mm Hi-ten Welding Lowers  
C 28.6mm Hi-ten Stanchion(CP or Ti Color)  
C 28.6mm Aluminum or Hi-ten Steerer  
(Cone C 30mm or C 39.85mm)  
100-120mm Travel  
Disc Brake  
1.55kg-2.2kg



**FATMAN**

26" 20" (FATBIKE)  
Pitch 171mm(4.0" 135mm)  
Adjustable Preload  
Spring Pressure System  
Hydraulic Lock-out  
Remote Lock-out  
Mechanical Lock-out  
Air Spring  
Forged Alloy Crown  
One-Piece Aluminum Lowers  
32mm Hi-ten Stanchion (CP or Ti Color)  
32mm Aluminum Hard-Anodize Plated  
28.6mm Aluminum or Hi-ten Steerer  
80-120mm Travel  
Disc Brake



**OUTMAN**

26" 27.5"  
Pitch 130mm  
Adjustable Preload  
Spring Pressure System  
Hydraulic Lock-out  
Remote Lock-out  
Mechanical Lock-out  
Air Spring  
Forged Alloy Crown  
One-Piece Magnesium Lowers  
28.6mm or 30mm Hi-ten Stanchion  
(CP or Ti Color)  
30mm Aluminum Hard-Anodize Plated  
28.6mm Aluminum or Hi-ten Steerer  
100-120mm Travel  
Disc Brake  
1.55kg-2.2kg



**VIGOR**

26" 27.5"  
Pitch 130mm  
Adjustable Preload  
Spring Pressure System  
Hydraulic Lock-out  
Remote Lock-out  
Air Spring  
Forged Alloy Crown  
One-Piece Magnesium Lowers  
C 30mm Aluminium Hard-Anodize  
Plated  
C 30mm Hi-ten Stanchion (CP or  
Ti Color)  
C 28.6mm Aluminium or Hi-ten Steerer  
(Cone C 30mm or C 39.85mm)  
100-120mm Travel  
Disc Brake  
1.55kg-2.5kg



**SUMMIT**

26" 27.5" 29"  
Pitch 130mm  
Adjustable Preload  
Spring Pressure System  
Hydraulic Lock-out  
Remote Lock-out  
Air Spring  
Forged Alloy Crown  
One-Piece Magnesium Lowers  
C 30mm Aluminium Hard-  
Anodize Plated  
C 30mm Hi-ten Stanchion  
(CP or Ti Color)  
C 28.6mm Aluminium or Hi-ten Tube  
(Cone C 30mm or C 39.85mm)  
100-120mm Travel  
Disc Brake  
1.65kg-2.5kg



**UF-70(FATBIKE)**

29" 27.5" 26" 24" 20"  
4.0"(135mm) 4.8"(150mm)  
Adjustable Preload  
Spring Pressure System  
Hydraulic Lock-out  
Remote Lock-out  
Air Spring  
Forged Alloy Crown  
C 38mm One-Piece Aluminium tube  
C 38mm One-Piece hi-ten tube  
Aluminum  
C 32mm Aluminium  
Hard-Anodize Plated  
C 30mm Hi-ten Tube (CP or Ti  
Color)  
C 28.6mm Aluminium or Hi-ten Tube  
(Cone C 30mm or C 39.85mm)  
80-120mm  
Disc Brake  
1.85kg-2.8kg



**RD-5000**

(FATBIKE)  
29" 27.5" 26" 24" 20"  
Width 135mm /150mm  
Forged Alloy Crown  
6061 Aluminium Tube Leg  
Forged Alloy Crown  
C 28.6mm 7050 Aluminium Steerer  
C 28.6mm Cr-mo or Hi-ten Tube  
(Cone C 30mm or C 39.85mm)  
Disc Brake / V-brake



**YM-99**

29" 27.5" 26" 24" 20"  
Pitch 130mm  
Adjustable Preload  
Spring Pressure System  
Hydraulic Lock-out  
Remote Lock-out  
Mechanical Lock-out  
Forged Alloy Crown  
One-Piece Steel Lowers  
28.6mm or 30mm Hi-ten Stanchion  
(CP or Ti Color)  
28.6mm Aluminium or Hi-ten Steerer  
50-120mm Travel  
Disc or V-Brake  
1.55kg-2.6kg



**FM-55**

29" 27.5" 26" 24" 20"  
Pitch 130mm  
Adjustable Preload  
Spring Pressure System  
Hydraulic Lock-out  
Remote Lock-out  
Mechanical Lock-out  
Forged Alloy Crown  
One-Piece Steel Lowers  
28.6mm or 30mm Hi-ten Stanchion  
(CP or Ti Color)  
28.6mm Aluminium or Hi-ten Steerer  
50-120mm Travel  
Disc or V-Brake  
1.55kg-2.6kg



**M-38**

29" 27.5" 26" 24" 20"  
Pitch 130mm  
Adjustable Preload  
Spring Pressure System  
Hydraulic Lock-out  
Remote Lock-out  
Mechanical Lock-out  
Forged Alloy Crown  
One-Piece Steel Lowers  
28.6mm or 30mm Hi-ten Stanchion  
(CP or Ti Color)  
28.6mm Aluminium or Hi-ten Steerer  
50-120mm Travel  
Disc or V-Brake  
1.55kg-2.6kg



**M-25**

29" 27.5" 26" 24" 20"  
Pitch 130mm  
Adjustable Preload  
Spring Pressure System  
Hydraulic Lock-out  
Remote Lock-out  
Mechanical Lock-out  
Steel Crown  
One-Piece Steel Lowers  
28.6mm or 30mm Hi-ten  
Stanchion (CP or Ti Color)  
28.6mm Aluminium or Hi-ten  
Steeer  
50-120mm Travel  
Disc or V-Brake  
1.55kg-2.6kg



**C-710**

26" 700c  
Pitch 107mm  
Adjustable Preload  
Spring Pressure System  
Hydraulic Lock-out  
Remote Lock-out  
Air Spring  
Forged Alloy Crown  
One-Piece Aluminium Lowers  
C 28.6mm Aluminium  
Hard-Anodize Plated  
C 28.6 Hi-ten Stanchion  
(CP or Ti Color)  
C 28.6mm Aluminium or Hi-ten  
Steeer  
(Cone C 30mm or C 39.85mm)  
40-60mm Travel  
Disc Brake or V-brake  
1.85kg-2.8kg



**RD-F01**

700c / 26"  
Full Carbon  
1-1/8" Carbon Steerer  
1-1/2" Carbon Steerer



**RD-FM15**

29" / 27.5" / 26"  
Full Carbon  
1-1/8" Carbon Steerer  
1-1/2" Carbon Steerer  
Disc brake



**RD-F02**

700c / 26"  
Full Carbon  
1-1/8" Carbon Steerer  
1-1/2" Carbon Steerer



**RD-A50**

27.5" / 26"  
Full Carbon  
1-1/8" Steel Steerer  
1-1/2" Over Alloy lowers  
Forged Alloy Dropout  
Disc Brake



**NM-300**

29" 27.5" 26" 24" 20"  
Pitch 125mm  
Adjustable Preload  
Spring Pressure System  
Hydraulic Lock-out  
Remote Lock-out  
Mechanical Lock-out  
Alloy Crown  
38.1mm Steel Stanchions  
31.8mm Steel Lowers  
(CP or Ti Color)  
28.6mm Aluminium or Hi-ten Steerer  
50-120mm Travel  
Disc or V-Brake  
1.55kg-2.6kg



**HD-215**

MATERIAL: STEEL  
DIAMETER: Φ31.8mm  
WIDTH: 620mm  
BACK SWEEP: 39°  
RISE: 38  
FINISH: SAND BLASTED AN BK or SILVER



**HD-212**

MATERIAL: STEEL & ALLOY  
DIAMETER: Φ25.4mm Φ31.8mm  
WIDTH: (Φ25.4) 540 560 580 600 620  
(Φ31.8) 560 580 600 620 640 660 680  
BACK SWEEP: (Φ25.4) 6° 10° 15°  
(Φ31.8) 6° 10° 15°  
FINISH: (AL)SAND BLASTED AN BK or SILVER  
(ST)CP BED D.SF



**HT-A12**

MATERIAL: 3D FORGED STEEL  
EXT: (±10°/25°)60 70 80 90 100 110 120  
(±17°)40 50 60 70 80 90 100 110 120  
RISE: ±10° ±17° ±25°  
HEIGHT: 41 45  
FINISH: SAND BLASTED AN BK or SILVER



**HT-A10**

MATERIAL: 3D FORGED STEEL  
EXT: 70 80 90 100 110 120  
RISE: ±7°  
HEIGHT: 35  
FINISH: SAND BLASTED AN BK or SILVER



**ST-A50**

Material: Aluminum & Steel  
Diam: Φ27.2 Φ28.6 Φ31.2  
Length: 250-300mm



**ST-A21**

Material: Aluminum  
Diam: Φ27.2 Φ28.6 Φ31.2  
Length: 250-300mm



**NM-100**

29" 27.5" 26" 24" 20"  
125mm  
Adjustable Preload  
Spring Pressure System  
Hydraulic Lock-out  
Remote Lock-out  
Air Spring  
C 38mm One-Piece Aluminium tube  
C 38mm One-Piece hi-ten tube  
Aluminum  
C 30mm Aluminium Hard-Anodize Plated  
C 30mm Hi-ten Tube (CP or Ti Color)  
C 28.6mm Aluminium or Hi-ten Tube  
(Cone C 30mm or C 39.85mm)  
100-120mm  
Disc Brake  
1.8kg-2.8kg





LIGHT STIFF ACTION-SMOOTH  
DRIFT will bring you a brand new riding  
experience !



**DRIFT**

**VAXA 32 EO 27.5**

**VAXA 32S EO  
27.5+**

**VAXA 32S ET  
27.5+**

►ISO4210  
MTB

MODEL NO	832	862 AIR	866S AMS	868S AMS
WHEEL SIZE	27.5"	27.5"	27.5"	27.5"
PITCH	130	130	148	148
FEATURES	<ul style="list-style-type: none"> <li>• Climb mode</li> <li>• Compression adjustable</li> <li>• Rebound adjustable</li> <li>• Air spring</li> </ul>	<ul style="list-style-type: none"> <li>• Remote lock-out</li> <li>• Hydraulic lock-out</li> <li>• Air spring</li> </ul>	<ul style="list-style-type: none"> <li>• Adjustable preload</li> <li>• Remote lock-out</li> <li>• Hydraulic lock-out</li> <li>• Coil spring</li> </ul>	<ul style="list-style-type: none"> <li>• Adjustable preload</li> <li>• Remote lock-out</li> <li>• Hydraulic lock-out</li> <li>• Coil spring</li> </ul>
CROWN	Forged alloy	Alloy	Forged alloy	Forged alloy
LOWER LEG	One-piece magnesium	One-piece magnesium ø40mm	One-piece magnesium ø40mm	One-piece magnesium ø40mm
STANCHIONS	ø32mm AL 7050 hard anodized	ø32mm AL 6061 hard anodized	ø32mm steel tube(TI)	ø32mm steel tube(TI)
BRAKE	Disc brake(PM)	Disc brake(PM)	Disc brake(PM)	Disc brake(PM)
ROTOR	160	160	160	160
AXLE	15mm QR	15mm QR	9	15mm QR
HUBWIDTH	100	100	110	110
WEIGHT	1.67kg	1.85kg	2.2kg	2.3kg
TRAVEL	100 120 140	100 120	100 120	100 120

# SUSPENSION FORK •

深圳信隆健康产业股份有限公司

中国广东省深圳市宝安区松岗街道办碧头社区第三工业区

邮编：518105

E: sales@hlcorp.com

www.hlcorp.com

Taiwan Bicycle Source 2018-2019



**VAXA 32AIR**

**VAXA 30S**

**VAXA 28S**

**565D**

►ISO4210  
MTB

►ISO4210  
MTB

<b>MODEL NO</b>	860S AMS	595S AMS	525 AMS
<b>WHEEL SIZE</b>	29" 27.5" 26"	29" 27.5" 26"	29" 27.5" 26" 24" 20"
<b>PITCH</b>	130	130	125
<b>FEATURES</b>	<ul style="list-style-type: none"> <li>Adjustable preload</li> <li>Remote lock-out</li> <li>Hydraulic lock-out</li> <li>Hydraulic rebound lock-out</li> </ul>	<ul style="list-style-type: none"> <li>Adjustable preload</li> <li>Remote lock-out</li> <li>Hydraulic lock-out</li> </ul>	<ul style="list-style-type: none"> <li>Adjustable preload</li> <li>Remote lock-out</li> <li>Hydraulic lock-out</li> </ul>
<b>CROWN</b>	Forged alloy	Forged alloy	Forged alloy
<b>LOWER LEG</b>	One-piece magnesium ø40mm	One-piece magnesium ø40mm	One-piece aluminum ø37mm
<b>STANCHIONS</b>	ø32mm steel tube(TI)	ø30mm steel tube(TI)	ø28.6mm steel tube(CP/TI)
<b>BRAKE</b>	Disc brake(PM)	Disc brake(PM)	Disc brake(PM)
<b>ROTOR</b>	160	160	160
<b>WEIGHT</b>	2.2kg	2.1kg	1.98kg
<b>TRAVEL</b>	100	100	100 60(24") 40(20")

<b>WHEEL SIZE</b>	29" 27.5" 26" 24" 20"
<b>PITCH</b>	120 (125mm/27.5"/29")
<b>FEATURES</b>	<ul style="list-style-type: none"> <li>Adjustable preload</li> <li>Machanical lock-out</li> <li>Hydraulic lock-ou</li> </ul>
<b>CROWN</b>	Forged alloy
<b>LOWER LEG</b>	One-piece aluminum ø35.0mm
<b>STANCHIONS</b>	ø25.4mm steel tube(CP/TI)
<b>BRAKE</b>	Disc brake(PM)
<b>WEIGHT</b>	1.7kg
<b>TRAVEL</b>	80 (26") 60(24") 80 (27.5"/29") 40(20")

# SUSPENSION FORK •

| **zoom** |

Taiwan Bicycle Source 2018-2019

**深圳信隆健康产业股份有限公司**

中国广东省深圳市宝安区松岗街道办碧头社区第三工业区

邮编：518105 E: sales@hlcorp.com

www.hlcorp.com



**389**                      **386**                      **106**                      **187D AMS**

►ISO4210  
MTB

PATENT

<b>WHEEL SIZE</b>	29" 27.5" 26" 24" 20"	29" 27.5" 26" 24" 20"	700C 20"	700C 26"
<b>PITCH</b>	125	125	--	116
<b>FEATURES</b>	<ul style="list-style-type: none"> <li>• Adjustable preload</li> <li>• Spring pressure system</li> <li>• Mechanical lock-out system</li> <li>• Hydraulic lock-out</li> </ul>	<ul style="list-style-type: none"> <li>• Adjustable preload</li> <li>• Mechanical lock-out</li> </ul>	<ul style="list-style-type: none"> <li>• Mono shock</li> </ul>	<ul style="list-style-type: none"> <li>• Adjustable preload</li> <li>• Mechanical lock-out</li> <li>• Hydraulic lock-out</li> <li>• Remote lock-out</li> </ul>
<b>CROWN</b>	Forged alloy	Forged alloy		Forged alloy
<b>LOWER LEG</b>	ø34.9mm welded hi-ten	ø34.9mm welded hi-ten	One-piece magnesium	One-piece aluminum ø39.0mm
<b>STANCHIONS</b>	ø28.6mm steel tube(CP/TI)	ø25.4mm steel tube(cp)	--	ø30mm steel tube(CP/TI)
<b>BRAKE</b>	Disc brake(IS) and V-brake	Disc brake(IS) & V-brake	Disc brake(IS) and V-brake	Disc brake(PM)
<b>ROTOR</b>	160	160	160	160
<b>WEIGHT</b>	2.18kg	2.08kg	1.5kg	2.19kg
<b>TRAVEL</b>	29" 80 27.5" 60 26" 50 24" 50 20" 40	29" 60 27.5" 60 26" 60 24" 50 20" 40	25	700C 65 / 26" 60

# SUSPENSION FORK •



Taiwan Bicycle Source 2018-2019

**深圳信隆健康产业股份有限公司**

中国广东省深圳市宝安区松岗街道办碧头社区第三工业区

邮编：518105

E: sales@hlcorp.com

www.hlcorp.com



**730 AMS**

**141**

**141D**

**410 E**

►ISO4210  
PEDELEC

<b>WHEEL SIZE</b>	700C 20"	700C 26"	700C	26" 24" 20"
<b>PITCH</b>	107	107	107	107
<b>FEATURES</b>	<ul style="list-style-type: none"> <li>• Adjustable preload</li> <li>• Mechanical lock-out</li> </ul>	<ul style="list-style-type: none"> <li>• Adjustable preload</li> <li>• Mechanical lock-out</li> </ul>	<ul style="list-style-type: none"> <li>• Adjustable preload</li> <li>• Mechanical lock-out</li> </ul>	<ul style="list-style-type: none"> <li>• Adjustable preload</li> <li>• Mechanical lock-out</li> </ul>
<b>CROWN</b>	Forged alloy	Forged alloy	Forged alloy	Forged alloy
<b>LOWER LEG</b>	One-piece aluminum ø34.5mm	One-piece aluminum ø 35.0mm	One-piece aluminum ø 35.0mm	ø31.8mm welded hi-ten
<b>STANCHIONS</b>	ø28.6mm steel tube(CP/TI)	ø25.4mm steel tube(CP/TI)	ø25.4mm steel tube(CP/TI)	ø25.4mm steel tube(cp)
<b>BRAKE</b>	V-brake	Disc brake/Roller-brake and V-brake	Disc brake/Roller-brake	V-brake
<b>ROTOR</b>	160	160	160	--
<b>WEIGHT</b>	2.05kg	1.74kg	1.74kg	1.8kg
<b>TRAVEL</b>	50 30(20")	45	45	26" 50 24" 40 20" 30

# SUSPENSION FORK •



►ISO4210  
MTB

### 620 DH

### 386 A

### 120 E

### 327 E

<b>WHEEL SIZE</b>	26" 24" 20"	29" 27.5" 26" 24" 20"	700C 26"	26" 24" 20"
<b>PITCH</b>	130	125	107	107
<b>FEATURES</b>	<ul style="list-style-type: none"> <li>• Spring pressure system</li> </ul>	<ul style="list-style-type: none"> <li>• Adjustable preload</li> <li>• Mechanical lock-out</li> </ul>	<ul style="list-style-type: none"> <li>• Adjustable preload</li> <li>• Mechanical lock-out</li> </ul>	<ul style="list-style-type: none"> <li>• Spring pressure system</li> </ul>
<b>CROWN</b>	Forged alloy	Forged alloy	Forged alloy	Pressed steel
<b>LOWER LEG</b>	ø44.5mm welded hi-ten	ø34.9mm welded hi-ten	ø31.8mm welded hi-ten	ø31.8mm welded hi-ten
<b>STANCHIONS</b>	ø37.5mm steel tube(cp)	ø25.4mm steel tube(cp)	ø25.4mm steel tube(CP)	ø25.4mm steel tube(cp)
<b>BRAKE</b>	Disc brake(IS) and V-brake	Disc brake(IS)	V-brake	V-brake
<b>ROTOR</b>	160	160		
<b>WEIGHT</b>	3.42kg	2.03kg	1.74kg	1.88kg
<b>TRAVEL</b>	26" 60 24" 50 20" 40	29" 60 24" 50 27.5" 60 20" 40 26" 60	30	26" 50 24" 40 20" 30

# SUSPENSION FORK •

# *Customized Service, Meeting Client Requirements, Quality Prioritized*

**B**icycle Parts & Accessories,  
Automotive & Motorcycle Components  
And Sports Goods

**M**aterials:  
Aluminum (7050, 7075,  
6066 & 6061) and steel



# HiXn

和新精密有限公司  
HEXIN PRECISION CO., LTD.

No.150.Renya Ln., Shetou Township, Changhua County 511, Taiwan

E-mail: [hexin.hxn@msa.hinet.net](mailto:hexin.hxn@msa.hinet.net) TEL: +886-4-8713379 FAX: +886-4-8712185



# 前叉避震器用卡匣 Front Fork's Damping Cartridges



## 前叉避震器用卡匣

功能：有線控鎖定，手動鎖定 以及 回彈可調 的多樣性

分類：軟硬可調，回彈可調，二合一，手動打氣

行程：80-140 (mm)

材質：鋁製，鐵製

Front Fork's Damping Cartridges

Functions: Wire Lock, Manual Lock, Rebound

Designs : Lockout, Rebound, Lockout & Rebound, Manual Pumping

Stroke : 80-140 (mm)

Material : Aluminum, Steel



萬得富股份有限公司

71752台南市仁德區勝利路132巷16號  
TEL:886-6-2707563 FAX:886-6-2707966  
E:-wdfmail@wdf-gaslift.com

**WAN DER FUL CO., LTD.**

NO.16, LN. 132, SHENGLI RD., RENDE DIST.,  
TAINAN CITY 71752, TAIWAN  
TEL: 886-6-2707563(Direct) FAX: 886-6-2707966  
www.wdf-gaslift.com



**PROFESSIONAL SPRING MANUFACTURER**



**壓縮彈簧**

Compression Springs



**扭轉彈簧**

Torsion Springs



**拉伸彈簧**

Extension Springs



**扭力彈簧**

Torsion Spring



**模具彈簧**

Mould Coil Springs



**折彎件**

Punching-bending Parts



**渦旋/板材/定力彈簧**

Constant Force Springs



**腳踏車/坐墊鐵弓**

Bike / Saddle-Iron Bow

**TAIWAN HEADQUARTERS**

加廣企業有限公司  
JIA GUANG ENTERPRISE CO., LTD.

台中市太平區光興路807巷100號  
No.100, Ln.807, Guangxing Rd., Taiping Dist., Taichung City,  
41149 Taiwan  
TEL:+886-4-22796546  
FAX:+886-4-22796545  
E-mail:jiaiguang2010@gmail.com

**CHINA BRANCH**

上精工五金制品(深圳)有限公司  
SHINE SPRING CO.,LTD.

廣東省深圳市福永街道第一工業村征程二路8號  
TEL:+86-755-27373496  
FAX:+86-755-27233495  
E-MAIL:shangjiangong147@126.com

**VIETNAM FACTORY**

加元五金責任有限公司





銘輝

# MING HUEI PROFIT CO., LTD.

No. 9, Ln61, Tien Chung Yung Rd., Sec. 2, Shihu Chen ,  
Changhua Hsien 514 Taiwan

Tel: +886-4-8814682, +886-4-8827889

Fax: +886-4-8851790

E-mail: ming.huiyang@msa.hinet.net

Executive: Chen Shu Mei



**Model MH-161NC**  
Material: Cr-Mo, Steel  
one-piece, octonal  
inner-stem



**Model MH-600**  
Material: 1-1/4 Cr-Mo or AL



**Model MH-500**  
Material: Stem 1-1/4 Cr-MO or AL

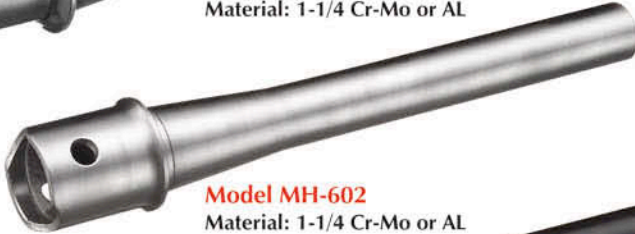

**Model MH-602**  
Material: 1-1/4 Cr-Mo or AL



**Model MH-501**  
Material: Stem 1-1/4 Cr-MO or AL



**Model MH-603**  
Material: 1-1/4 Cr-Mo or AL



**Model MH-605**  
Material: Cr-Mo or AL  
28.6x25.4



**Model MH-666**  
Material: Alloy



**Model MH-162**  
Material: Cr-Mo, Steel  
one-piece sleeve



**Model MH-270AL**  
Hidden Stem  
Material: Aluminum  
Alloy 6061T6 or Cr-Mo, Steel 11A



**Model MH-263**  
One-piece Stem  
Material: Cr-Mo



**Model MH-269**  
Hidden Stem  
Material: AL



**Model MH-229** Expanded and hidden stem  
Material: Cr-Mo or Steel 11A



**Model MH-262AL**  
Extension tube  
Material: 11A & AL



**Model MH-258**  
Fork crown stem  
Material: 11A & Cr-Mo / 38.1X28.6



**Model MH-87**  
Material: Alloy ,Steel  
Cr-Mo Heat-treated tube ; logo laser-etched to customer specification



**Model MH-169**  
Hidden Stem  
Material: Cr-Mo, Steel , one-piece sleeve



Seamless integrally molded



**Model MH-509**  
6061 & 7005



**Model MH-508**  
6061 & 7005



**Model MH-667**  
Seatpost  
Material: 11A & Cr-Mo



**Model MH-668**  
Seatpost  
Material: 11A & Cr-Mo



**Model MH-88**  
Fork head stem for electric bikes



**Model MH-268**  
Spiraled tube



**Model MH-607**  
Material: 31.8, Cr-Mo



**Model MH-206**  
Head lug  
Material: Cr-Mo or Steel 11A



**Model MH-366**  
Seatpost  
Material: Cr-Mo or Steel 11A



**Model MH-288**  
Seatpost  
Material: Cr-Mo or Steel 11A



**Model MH-701**  
Material: 13A



**Model MH214NC**  
B.B Sheels  
Material: STKM,Cr-Mo



**Model MH-207**  
B.B Sheels  
Material: STKM,Cr-Mo



**Model MH-289B**  
BB for tricycles.  
Material: 11A & AL



**Model MH-289**  
BB for tricycles.  
Material: 11A & AL



**Model MH-106H**  
Diam:40X38X34mm  
Length:60~300mm  
Material: STKM,Cr-Mo



**Model MH-166 NC**  
Head lug  
CNC / Material: STKM11A

**Model MH-704**  
Material: 13A

# GEMINI BICYCLE INC. 展暉工業有限公司

Tel: +886-4-26711667 Fax: +886-4-26711668 No.81-2 Wenqu Rd., Dajia Dist., Taichung City 43750, Taiwan.

Email: gemini@gbilee.tw Web: www.gbi.com.tw



## Tapered Steerer

Front Fork Steerer (G12)

Dia : 1-1/8"~ 1-1/2"

Material : Aluminum (60XX/70XX)



## Suspension Inner Tubes

Processing : Custom

Material : Aluminum (60XX/70XX), CR-MO, Steel

Finish : Hard Anodizing, Hard Chrome, CP



## Drawing Tubes

Front Fork Steerer (G10)

Processing : Custom/Standard

Material : CR-MO, Steel,  
Aluminum (60XX/70XX)



## Reduce Tubes

Front Fork Steerer (G07/G08)

Processing : Custom/Standard

Material : CR-MO, Steel, Aluminum



Dynamic and Fatigue Testing System



## **Custom Tubes**

Gemini Bicycle Inc. is an ODM/OEM and aims to serve our customer by providing the highest quality and full service of customization.



# NAN LONG BICYCLE MATERIAL CO., LTD.

Add: NO. 30, Lane 362, Section 1, Tzung An Street, Tainan, Taiwan.

Tel: 886-6-3555080 Fax: 886-6-3563800

http://www.nan-long.com.tw

E-mail: service@nan-long.com.tw

南 隆



**FRAME TUBE**  
Double Butted Tube

### NLF-01

Material : 7050,6066.Cr-Mo  
One Piece Front Fork Stem



1-1/8" / 1.5"

### NLF-02

Material : 7075, 7050, 6066.Cr-Mo



1-1/8" / 1.4"



1-1/8"

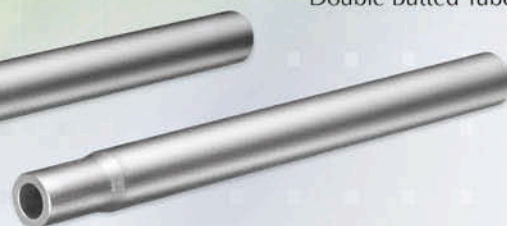

1-1/8"



SYSTEM NO.42 HEAD TUBE



SYSTEM NO.50 HEAD TUBE



NLH01



NLH02



NLH03



NLH04



NLH05



NLB01



NLB02



NLB03



NLB04



NLB05

### HEAD TUBE

Material:11A & CRMO  
Any size available  
For BMX,ROAD,MTB

### B.B Shell

Material:11A & CRMO  
Any size available  
For BMX,ROAD,MTB



OEM CNC PARTS

**Specialized tube maker**

**CNC Technology**

**OEM**

自行車: 前叉豎管 / 車架頭管, 五通 / CNC車床加工

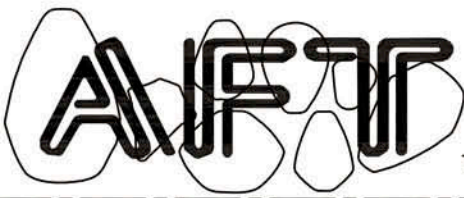

DOWN TUBE

L:Variable quantity  
UNIT:mm

AHF-DT-0208		Hydroforming	
BASE:	Ø82	MATERIAL:	7005&6061
DB:	(HT)2.2*1.8T	WEIGHT:	805g 6061#

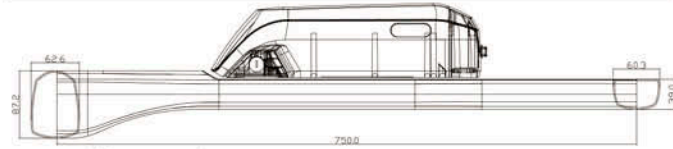

HT端(Fixed Side)

BB端(Cutted Side)

AHF-DT-0209		Hydroforming	
BASE:	Ø70	MATERIAL:	7005&6061
DB:	(HT)2.2*1.8T	WEIGHT:	765g 6061#

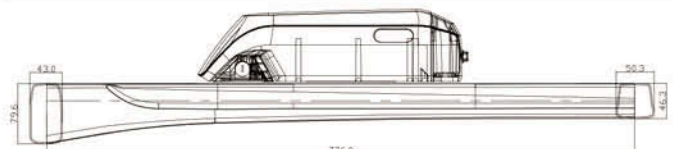

HT端(Fixed Side)

BB端(Cutted Side)

AHF-DT-0211		Hydroforming	
BASE:	Ø67	MATERIAL:	7005&6061
DB:	(HT)2.2*1.8T	WEIGHT:	720g 6061#

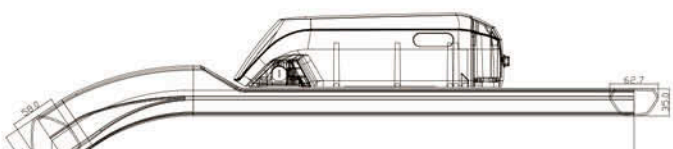

HT端(Fixed Side)

BB端(Cutted Side)

AHF-DT-0212		Hydroforming	
BASE:	Ø76	MATERIAL:	7005&6061
DB:	(HT)2.2*1.8T	WEIGHT:	790g 6061#

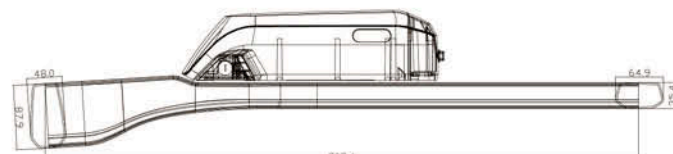
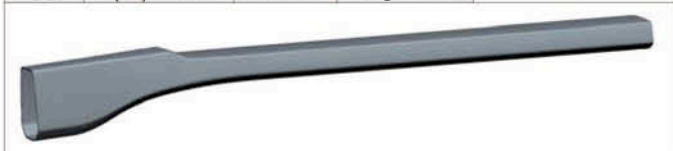

HT端(Fixed Side)

BB端(Cutted Side)

AHF-DT-0213		Hydroforming	
BASE:	Ø67	MATERIAL:	7005&6061
DB:	(HT)2.2*1.8T	WEIGHT:	910g 6061#



SHIMANO BT-E8010

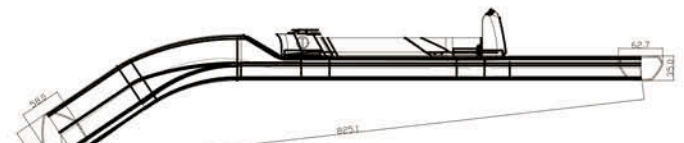

HT端(Fixed Side)

BB端(Cutted Side)

AHF-DT-0217		Hydroforming	
BASE:	Ø98	MATERIAL:	7005&6061
DB:	(HT)4.2*3.0T	WEIGHT:	1740g 6061#



BOSCH



HT端(Fixed Side)

BB端(Cutted Side)

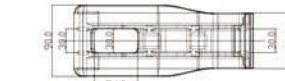

AHF-EBB-0003-A

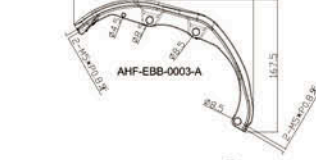

AHF-EBB-0003-B



AHF-YK-0003



PT-500  
BOSCH-CX

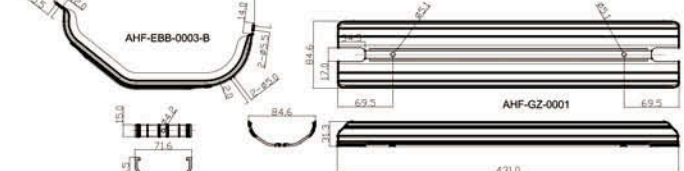

AHF-GZ-0001

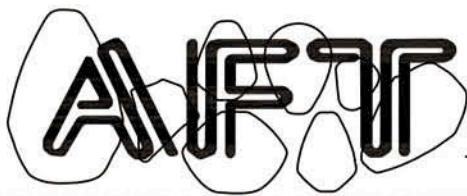

TOP TUBE

L:Variable quantity  
UNIT:mm

AHF-TT-0125		Hydroforming	
BASE: Ø96	MATERIAL: 6061		
DB: (HT)1.5*1.2*1.6T	WEIGHT: 420g	6061#	



HT端(Fixed Side)

ST端(Cutted Side)

AHF-TT-0148		Hydroforming	
BASE: Ø96	MATERIAL: 6061		
DB: (HT)1.6*1.2*1.6T	WEIGHT: 385g	6061#	



HT端(Fixed Side)

ST端(Cutted Side)

AHF-TT-0162		Hydroforming	
BASE: Ø80/Ø30	MATERIAL: 7005&6061		
DB: (HT)1.4*1.0*1.6*2.4T	WEIGHT: 760g	6061#	

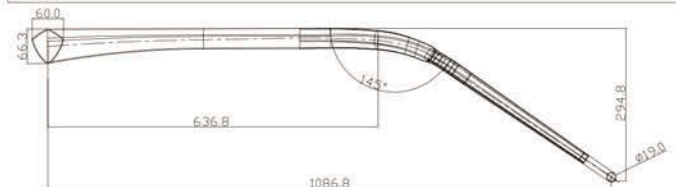

HT端(Cutted Side)

ST端(Fixed Side)

AHF-TT-0187		Hydroforming	
BASE: Ø64	MATERIAL: 7005&6061		
DB: (HT)1.8*1.4*1.8T	WEIGHT: 495g	6061#	



HT端(Cutted Side)

ST端(Fixed Side)

SUBJECT TO THE SAMPLE

AHF-TT-0188		Hydroforming	
BASE: Ø66	MATERIAL: 7005&6061		
DB: (HT)1.6*1.2*1.4T	WEIGHT: 370g	6061#	

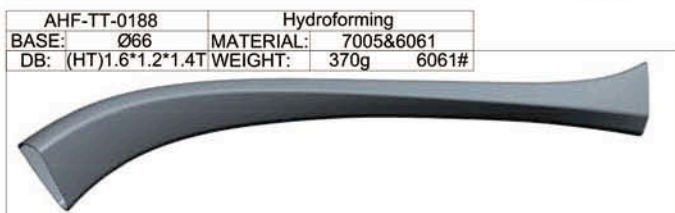

HT端(Fixed Side)

ST端(Cutted Side)

AHF-TT-0192		Hydroforming	
BASE: Ø60	MATERIAL: 7005&6061		
DB: (HT)1.6*1.2*1.4T	WEIGHT: 425g	6061#	



HT端(Fixed Side)

ST端(Cutted Side)

AHF-TT-0193		Hydroforming	
BASE: Ø60	MATERIAL: 7005&6061		
DB: (HT)1.6*1.2*1.4T	WEIGHT: 425g	6061#	



HT端(Fixed Side)

ST端(Cutted Side)

AHF-TT-0194		Hydroforming	
BASE: Ø60	MATERIAL: 7005&6061		
DB: (HT)1.6*1.2*1.4T	WEIGHT: 425g	6061#	



HT端(Fixed Side)

ST端(Cutted Side)

AHF-TT-0197		Normal-forming	
BASE: Ø53	MATERIAL: 7005&6061		
DB: (HT)1.6*1.2*1.4T	WEIGHT: 385g	6061#	

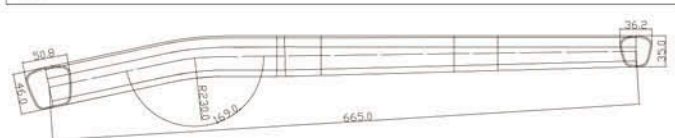

HT端(Fixed Side)

ST端(Cutted Side)

# INNOVATION IS OUR MAIN POWER FOR CONTINUOUS BREAKTHROUGH

## DESIGN AND PROCESS ON ALUMINUM TUBE



1. Diameter  $\leq 150$ (mm) butted machine
  2. Diameter  $\leq 150$ (mm) concave head machine
  3. Diameter  $\leq 130$ (mm) taper machine
  4. High-speed CNC machine center for mould
- The above machines especially for E-bike downtube  
built battery



**HYDRO-FORMING**  
**MECHANIC-FORMING**  
**ALUMINUM TUBING FORMING**

九川實業股份有限公司  
台中市大雅區神林路一段193-1號  
TEL:886-4-25676851 FAX:886-4-25682995  
E-mail: aforge@aforge.com.tw  
aforge@ms29.hinet.net

**A-FORGE ENTERPRISE CO., LTD**  
NO. 193-1, SECTION 1, SHENLIN ROAD, DAYA DISTRICT  
TAICHUNG CITY, 428

天成車料(深圳)有限公司  
九川金屬製品(深圳)有限公司  
深圳市觀瀾街道獅徑社區洗屋村工業一路6號  
TEL:86-755-28012794/6 FAX:86-755-28012795  
E-mail: aforge@vip.163.com

**TIANCHEN BICYCLE-PARTS(SHENZHEN) CO., LTD**  
**A-FORMING METAL PRODUCTS(SHEN ZHEN) CO., LTD**  
NO.6 OF 1ST INDUSTRY RD, XIANWU GROUP SHIJING VILLAGE,  
GUANLAN TOWN, BAO AN COUNTRY, SHENZHEN, CHINA



**EVOLUTION**  
from the **FUTURE**

# FOUNDER LAND GROUP

[www.founderland.com.tw](http://www.founderland.com.tw)  
[www.eco.com.tw](http://www.eco.com.tw)



## TAIWAN OFFICE FOUNDER LAND CO., LTD.

No.980, Sec. 2, Dongda Rd., Daya Dist.,  
Taichung City, 42879, Taiwan  
TEL: +886-4-25686240  
FAX: +886-4-25663645  
E-mail: [sales@founderland.com.tw](mailto:sales@founderland.com.tw)

## FOUNDER LAND PRECISION HARDWARE(D.G) CO., LTD.

1-3F, East 5 Bldg., No.19, Jinfu Road, Liaobu Town,  
Dongguan City, Guangdong, China, 523406  
TEL: 769-82631351~3  
FAX: 769-82631350  
E-mail: [eco88@vip.163.com](mailto:eco88@vip.163.com)

## THAILAND FACTORY FOUNDER LAND (THAILAND) CO., LTD.

206/7 Moo.2 Phraeksa Subdistrict,  
Mueang Samutprakran, Samutprakran 10280  
TEL: 66-21369516  
FAX: 66-21369518  
E-mail: [fdl@founderland.co.th](mailto:fdl@founderland.co.th)





HUA HSINES  
華承

SHIMANO BATTERY E8020 SERIES



HUA HSINES INDUSTRY CO., LTD  
HUA HSINES METAL MANUFACTURES COMPANY (SHEN ZHEN)  
CHINA: 3rd Industrial Zone, Da Wang Shan Village, Shajing Town,  
Bao an County, Shenzhen, China  
http://www.huahsines.com.tw/ E-Mail: huahsine@vip.163.com  
TEL: 86-755-27225278, 27225378, 27225195  
FAX: 86-755-27225778

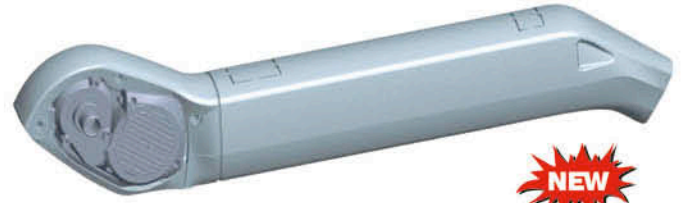

**1 DOWN TUBE: HH-D96-1200**

**2 MOTOR MOUNT: HMM-242110**

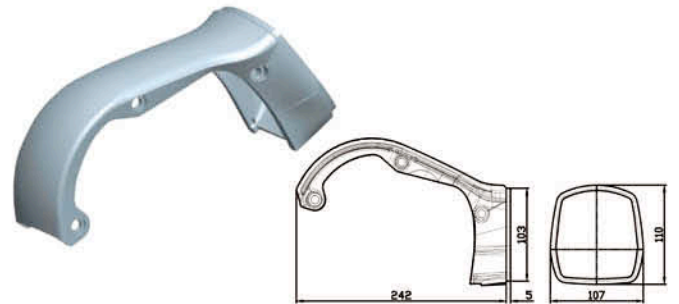
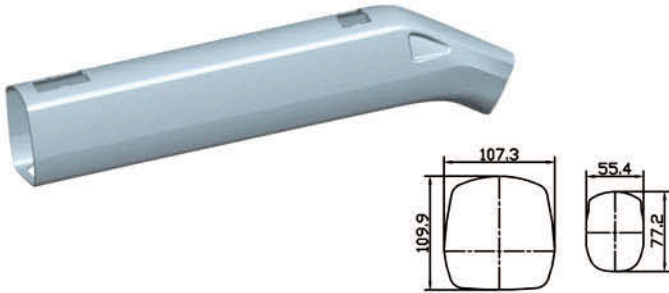

**3 SUSPENSION MOTOR MOUNT: HSMM-242111**

**4 LADY MOTOR MOUNT: HLMM-185110**

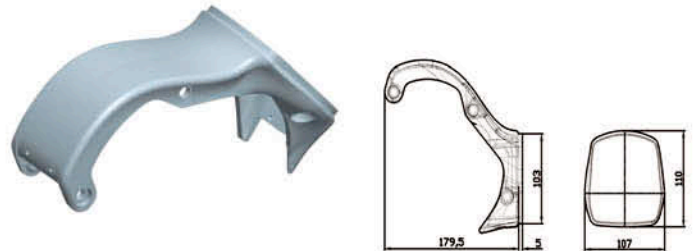
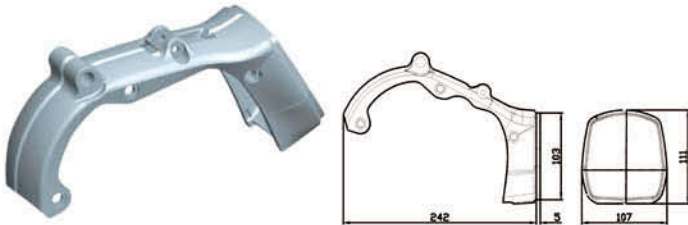

**5 MOTOR COVER: HMC-23171**

**6 LADY MOTOR COVER: HLMC-23295**

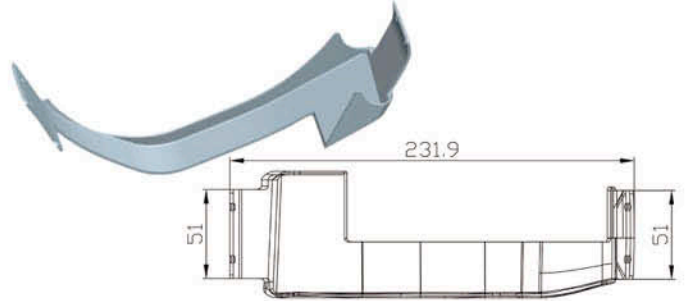
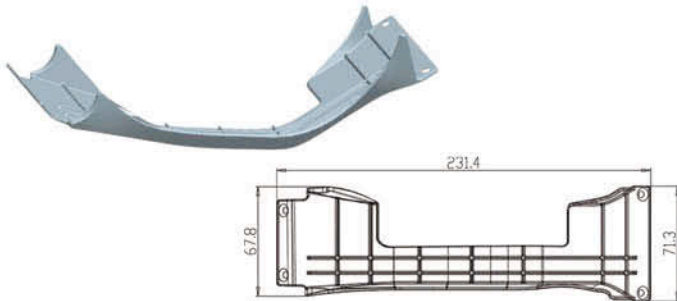

**7 BATTERY MOUNT: HBM-6955/HBM-8359**

**8 BATTERY COVER: HBC-41581**

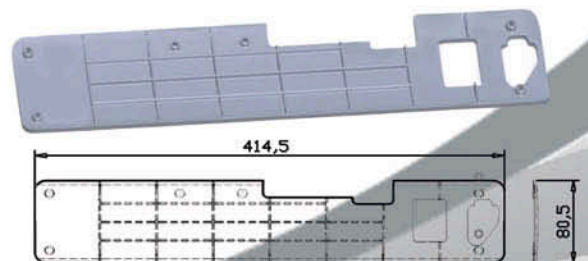
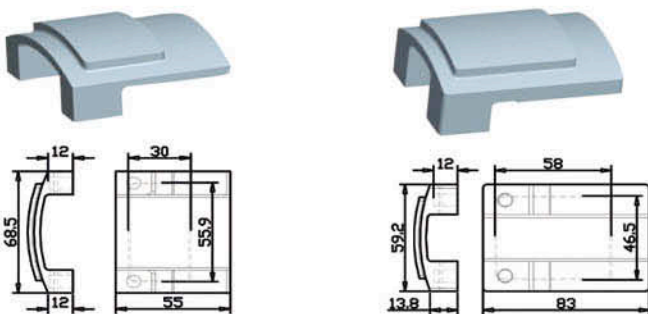





**DARFON BATTERY E4C0C SERIES**



**1 DOWN TUBE: HH-D99-9600**

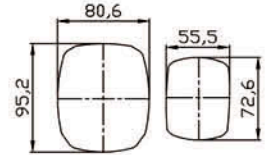
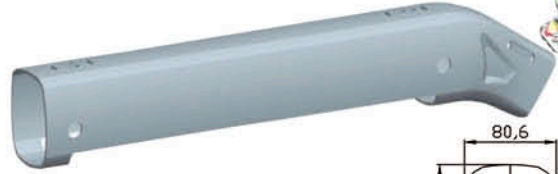

**2 MOTOR MOUNT: HMM-24795**



**3 SUSPENSION MOTOR MOUNT: HSMM-24795**

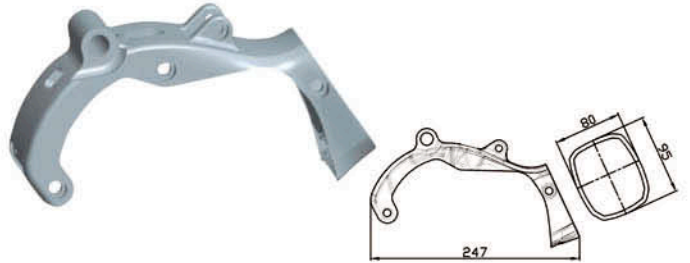

**4 MOTOR COVER: HMC-21771**  
**5 BATTERY COVER: HBC-41773**

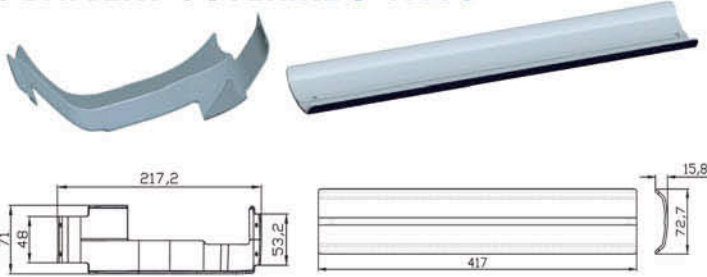

**6 BATTERY MOUNT: HBM-5026/HBM-5017**

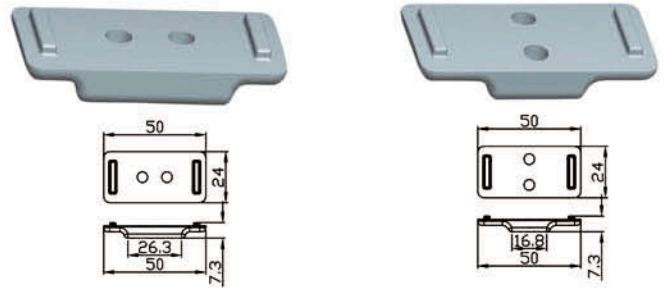

**BMZ BATTERY V7 SERIES**



**1 DOWN TUBE: HE-D100-1000**  
**2 HEAD TUBE CONNECT: HHTC-9258**

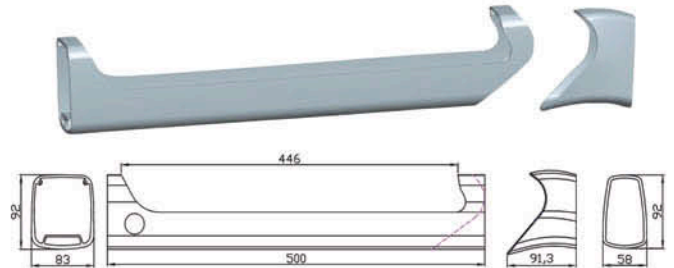

**3 MODEL MOUNT: HMM-235139**

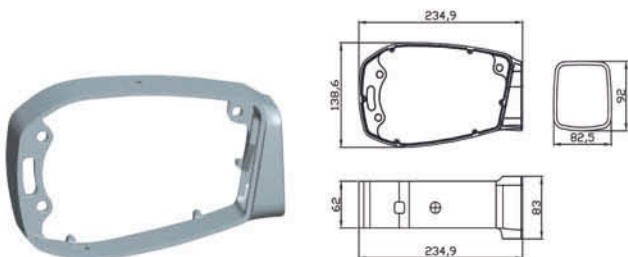

**TOP TUBE**  
**MODEL: HO-480-49**

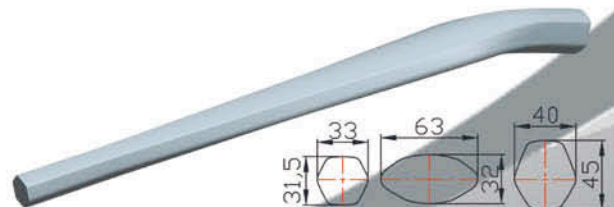



# Stainless Steel Material

## High Quality \* High Grade



- Proficient in manufacturing high strength of stainless steel tube and plate as well as passing harsh test of EU ISO
- Satin380 owns resistance to oxidation, high processing toughness of material, superb thin thickness and Green Products of extraordinary lightweight
- Satin301 is provided with excellent ductility and cold working, which is appropriate for working of hydroforming

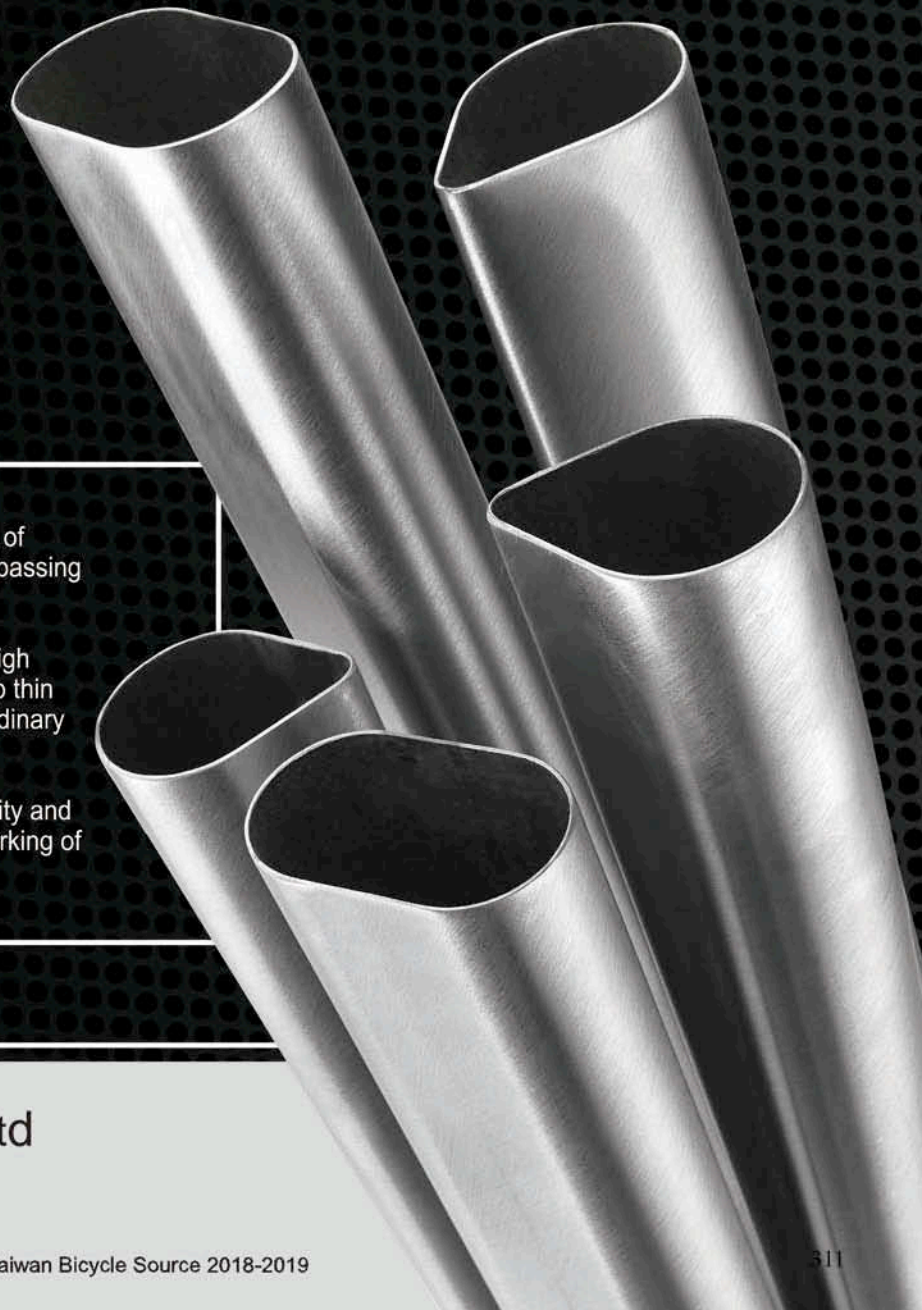

Satin Technology Co., Ltd

No. 27 Erkan Rd. Waipu Dist. Taichung 43858  
TEL:(04)2683-7899 FAX:(04)2683-2099  
E-mail:satin20141111@gmail.com

Taiwan Bicycle Source 2018-2019

# TAIPEI CYCLE

Oct. 31-Nov. 3, 2018



A New Worldview  
On Cycling



Visit us on website:

[Taipcycle.com.tw](http://Taipcycle.com.tw)

Organizer:



# TANGE

Since 1920



**ULTIMATE**  
HEAT-TREATED  
EXTRALIGHT  
CR-MO DOUBLE BUTTED TUBES  
TANGE



**ULTIMATE  
KEIRIN**  
★★★★★  
HEAT-TREATED  
EXTRALIGHT  
CR-MO DOUBLE BUTTED TUBES  
TANGE



**JP  
PRESTIGE  
JAPAN**  
HEAT-TREATED  
CR-MO DOUBLE BUTTED TUBES  
TANGE



**JP  
PRESTIGE**  
HEAT-TREATED  
CR-MO DOUBLE BUTTED TUBES  
TANGE



CHROMIUM MOLYBDENUM STEEL  
**CHAMPION  
No.1**  
DOUBLE BUTTED TUBES  
TANGE



CHROMIUM MOLYBDENUM STEEL  
**CHAMPION  
No.2**  
DOUBLE BUTTED TUBES  
TANGE



CHROMIUM MOLYBDENUM STEEL  
**CHAMPION  
No.3**  
DOUBLE BUTTED TUBES  
TANGE



**TANGE**  
CR-MO PG tubes



# 升励五金(深圳)有限公司

## SANLEAD METAL (SHENZHEN) CO.,LTD

Sanlead Metal specializes in producing high quality bicycle tubing since 1994.

We manufacture aluminum tubes of various standard and custom shapes with perfected processes such as butting, tapering, logo stamping and hydro-forming. We make it all happen for you!!

### Hydroforming TT

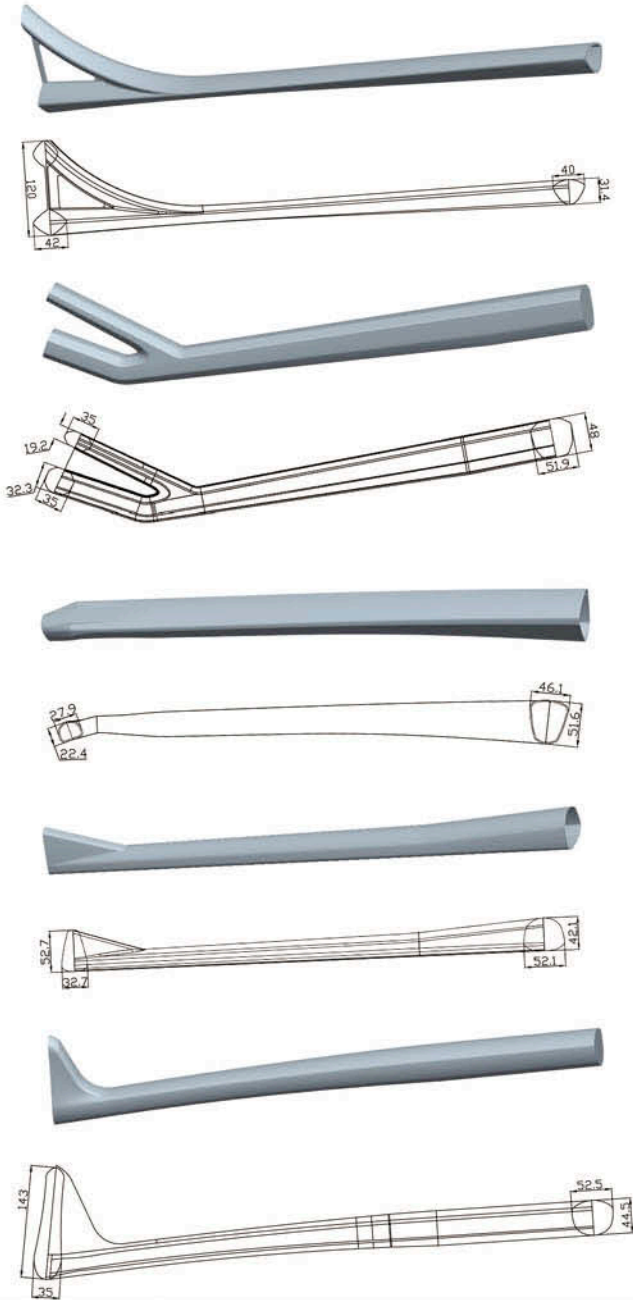

### Hydroforming ST

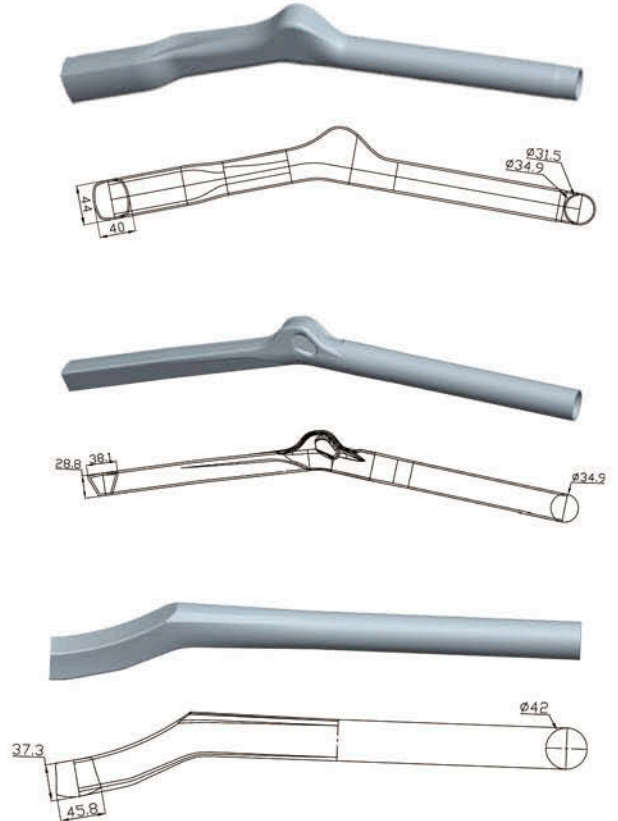

#### 太仓 (TAICANG)

地址: 江苏省太仓港经济经济技术开发区新区郑和东路352号  
 No. 352, New District Zhenghe East Road, Economic and  
 Technological Development Zone, TaiCang Port, Jiangsu Province.  
 Tel: 0512-53289157/8 Fax: 0512-53289159

#### 深圳 (SHENZHEN)

中国深圳市宝安沙井街道金沙头工业区康民路6号  
 NO. 6 Kangmin Rd, Jinshatou Industrial Area, Shajing  
 Town, Baoan District, Shenzhen City, China  
 Tel: 86-755-29887889 Fax: 86-755-29889628/9646  
 Email: sanlead@szonline.net



鑫升勵貿易（深圳）有限公司  
Sanlead Enterprise Co., Ltd

太倉升達機械有限公司  
TaiCang Shengda Machinery Co., Ltd

**STC Hydroforming DT**

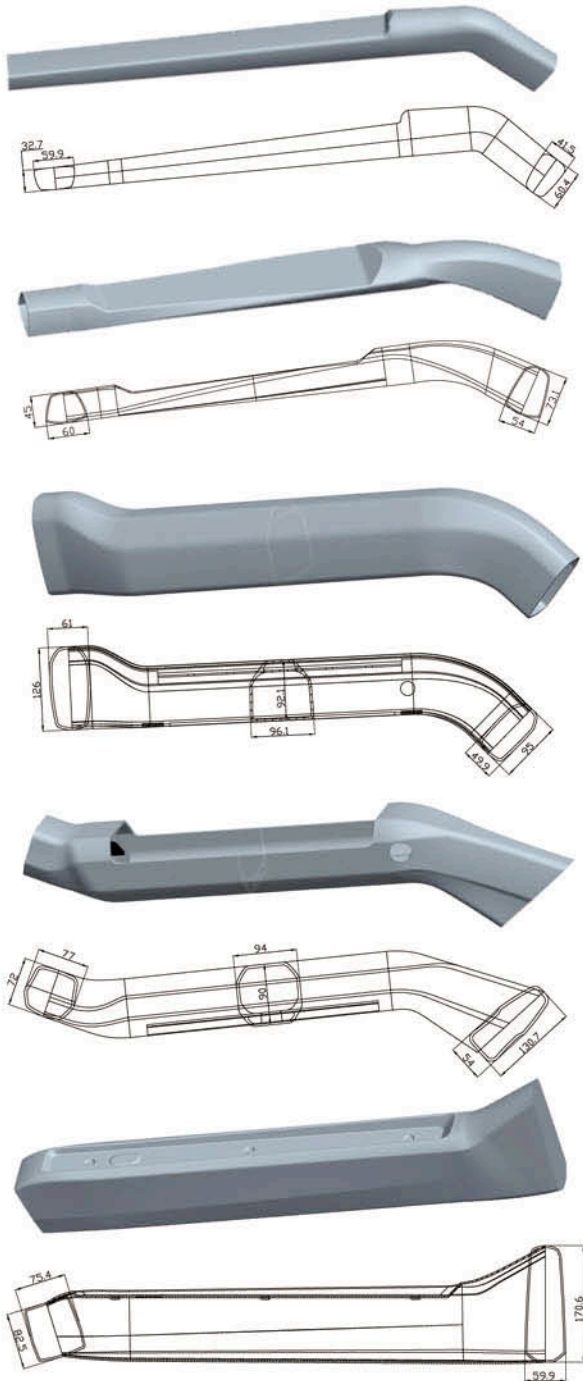

**Hydroforming SS/CS STC**

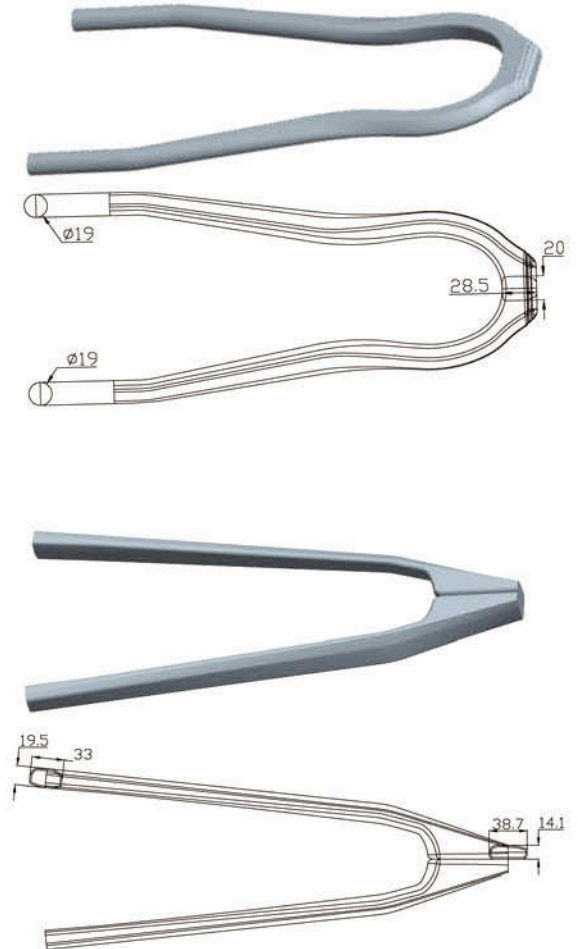

深圳 (SHENZHEN)  
中國深圳市寶安區沙井街道金沙頭工業區康民路6號  
NO. 6 Kangmin Rd, Jinshatou Industrial Area, Shajing  
Town, Baoan District, Shenzhen City, China  
Tel: 86-755-29887889 Fax: 86-755-29889628/9646  
Website: [www.sanlead.com](http://www.sanlead.com)

太倉 (TAICANG)  
地址：江蘇省太倉港經濟技術開發區新區鄭和東路352號  
No. 352, New District Zhenghe East Road, Economic and  
Technological Development Zone, TaiCang Port, Jiangsu Province.  
Tel: 0512-53289157/8 Fax: 0512-53289159  
Email: [sanlead@szonline.net](mailto:sanlead@szonline.net)





**ALLOTEC CO., LTD.**  
No.81, Lane 166, Xiquan Rd.,  
Shengang Township,  
Changhua County(50591),  
Taiwan.  
Tel: 886-4-7987686  
Fax: 886-4-7985786  
E-mail: allotec@allotec.com.tw  
Http://www.allotec.com.tw

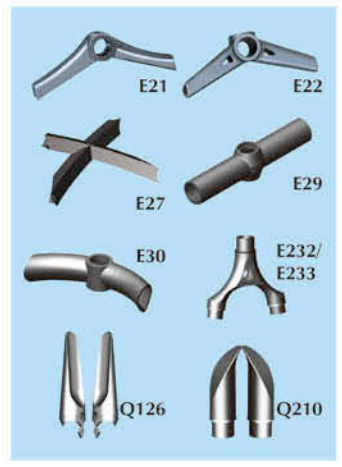
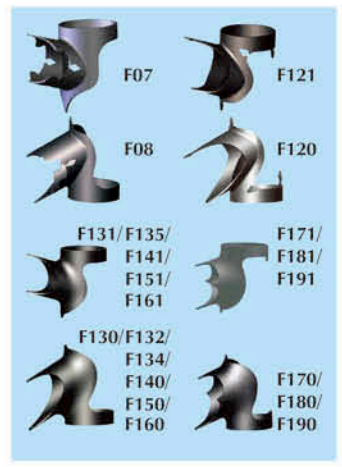
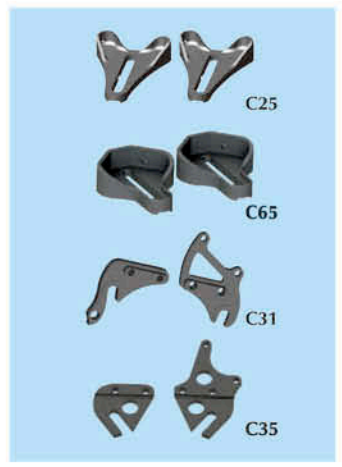
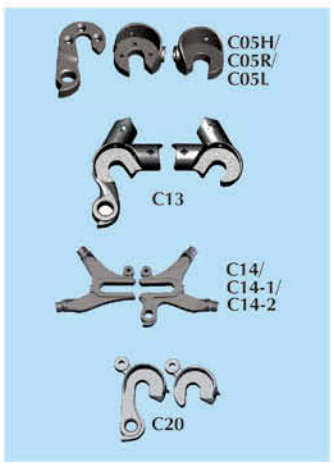
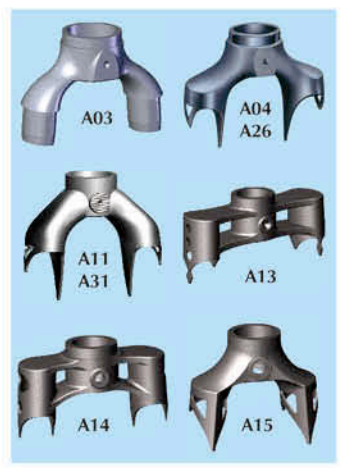



## Head Lug

Material: Steel, Alloy, Cr-mo,  
Stainless  
Length: 50~300mm  
OD: 62~31.8mm  
ID: 56~30mm



## Bottom Bracket Shell

Material: Steel, Alloy, Cr-mo,  
Stainless  
Length: 60~132mm  
OD: 62~30mm  
ID: 56~34mm



## Front Fork Stem

Material: Steel, Cr-mo  
Length: 100~500mm  
OD: 48~28.6mm  
ID: 30~25.4mm



## CNC Engraving

Manufacturer according to  
customer demand.



## B.B. Appurtenances

Material: Steel, Alloy, Brass,  
Plastic, Powder





**將頂科技有限公司(鍛造廠)**  
**JIANG DING TECHNOLOGIES CO., LTD.(FORGING FACTORY)**  
 # 64-8 GUANGZIWEI, GANGWEI  
 COUNTRY, ANDING TOWN TAI NAN COUNTY  
 74562 TAIWAN  
 Tel: 886-6-5976037  
 Fax: 886-6-5976035  
 E-mail: jdtech.sos@gmail.com  
 www.jdforging.com

**將頂科技(深圳)有限公司**  
**JIANG DING TECHNOLOGIES (SHENZHEN) CO., LTD.**  
 #.2 SITE. DA SONG YUAN INDUSTRIAL PART ,  
 JIANG XIA COUNTRY, GUANG MING STREET ,  
 BAO AN DISTRICT, SHENZHEN CITY  
 Tel:86-755-27430456  
 Fax:86-755-27430459  
 E-mail:jiang-jd@vip.163.com



9D-0201-2



9F-0058B



9F-0320



9D-0252



9D-0202



9D-0246



9F-0335

9H-0090  
9D-0239

9D-0201-1



9F-0336



9F-0316



9F-0314



9F-0322



9F-0327



9F-0333



9F-0315



9F-0342



9D-0245



9D-0223-49



9F-0356



9F-0343



9F-0265  
9K-0277  
T-0065



9F-0129



9D-0240



9F-0331



9F-0151



9F-0398



9F-0183



9F-0278



9F-0208



9F-0214



9F-0215



9F-0108



9F-0277



9F-0228



9F-0400



9F-0242



9F-0424



9F-0375



9F-0298



9F-0300



9F-0313



9F-0149



9F-285



9F-0337



9F-0141



9E-0013



9E-0019



9E-0022



9E-0044



9E-0045



9H-0044



9H-0083



9H-0045



9H-0089



9H-0107



9H-0087



9H-0085



9H-0086



9H-0233



9H-0277



9H-0065



9C-0058



9Q-0188



9Q-0261



9C-0051



T-0006



T-0011



T-0010



T-0024



T-0044



9Q-0277



9Q-0432



9Q-0323



9Q-0037



9K-0130



9K-0372



9K-0373

九川實業股份有限公司  
台中市大雅區神林路一段193-1號  
TEL:886-4-25676851 FAX:886-4-25682995  
E-mail: aforge@aforge.com.tw aforge@ms29.hinet.net

**A-FORGE ENTERPRISE CO., LTD**  
NO. 193-1, SECTION 1, SHENLIN ROAD,  
DAYA DISTRICT TAICHUNG CITY, 428

天成車料(深圳)有限公司  
九川金屬製品(深圳)有限公司  
深圳市觀瀾街道獅徑社區洗屋村工業一路6號  
TEL:86-755-28012794/6 FAX:86-755-28012795  
E-mail: aforge@vip.163.com

**TIANCHEN BICYCLE-PARTS(SHENZHEN) CO., LTD**  
**A-FORMING METAL PRODUCTS(SHEN ZHEN) CO., LTD**  
NO.6 OF 1ST INDUSTRY RD, XIANWU GROUP SHIJING VILLAGE,  
GUANLAN TOWN, BAO AN COUNTRY, SHENZHEN, CHINA

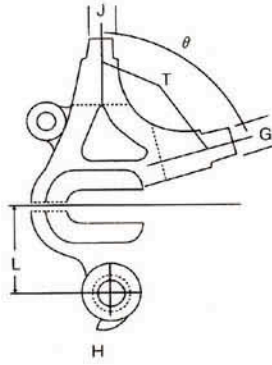

**Model A-F3306**

	$\theta$	T	L	H	G	J
A	49°	7.0			19	19



**Model A-F3306-A**

	$\theta$	T	L	H	G	J
A	49°	7.0			19	19



**Model A-F3306-B**

	$\theta$	T	L	H	G	J
A	49°	7.0	28	30°	19	19



**Model A-F3512**

	$\theta$	T	L	H	G	J
A	45°	8.0	28	28°	22	19
B	52°	8.0	28	28°	22	19



**Model A-F3513**

	$\theta$	T	L	H	G	J
A	45°	8.0	29	28°	22	19
B	54°	8.0	29	28°	22	19
C	61°	8.0	29	28°	22	19
D	68°	8.0	29	28°	22	19



**Model A-F3513-DB**

	$\theta$	T	L	H	G	J
A	45°	8.0	29	28°	24.2	21
B	54°	8.0	29	28°	24.2	21
C	61°	8.0	29	28°	24.2	21
D	68°	8.0	29	28°	24.2	21



**Model A-F3518**

	$\theta$	T	L	H	G	J
A		8.0	29	28°	15	



**Model A-F3523**

	$\theta$	T	L	H	G	J
A	53°	8.0	26	30°	14.5	10.5
B	61°	8.0	26	30°	14.5	10.5
C	64°	8.0	26	30°	14.5	10.5
D	67°	8.0	26	30°	14.5	10.5
E	69°	8.0	26	30°	14.5	10.5
F	72°	8.0	26	30°	14.5	10.5



**Model A-F3523-A**

	$\theta$	T	L	H	G	J
A	72°	8.0	26	30°	14.5	6



**Model A-F3523-B**

	$\theta$	T	L	H	G	J
A	53°	8.0	26	30°	14.0	10.0
B	61°	8.0	26	30°	14.0	10.0
C	64°	8.0	26	30°	14.0	10.0
D	67°	8.0	26	30°	14.0	10.0
E	69°	8.0	26	30°	14.0	10.0



**Model A-F3526**

	$\theta$	T	L	H	G	J
A		8.0	28	30°	19	13



**Model A-F3526-C**



**Model A-F3527**

	$\theta$	T	L	H	G	J
A		8.0	29	28°		



**Model A-F3527-A**

	$\theta$	T	L	H	G	J
A		8.0	29	28°		

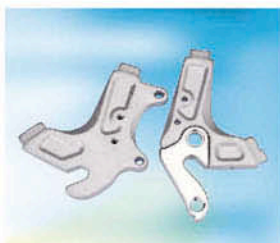

**Model A-F3528**

	$\theta$	T	L	H	G	J
A	45°	8.0	28	40°	20	15.4
B	51°	8.0	28	40°	20	15.4
C	57°	8.0	28	40°	20	15.4
D	61°	8.0	28	40°	20	15.4
E	65°	8.0	28	40°	20	15.4



**Model A-F3559**

	$\theta$	T	L	H	G	J
A	52°	8.0	30	36°	18	19



**Model A-F3559-B**



**Model A-F3570**

	$\theta$	T	L	H	G	J
A		8.0	29	28°		



**Model A-F3572**

	$\theta$	T	L	H	G	J
A		8.0	30	30°		



**Model A-F3572-A**

	$\theta$	T	L	H	G	J
A	52°	8.0	30	36°	18	19



**Model A-F3597**

	$\theta$	T	L	H	G	J
A		8.0	29	30°		



**Model A-F3600**



**Model A-F3600-C**



**Model A-F3602**



**Model A-F3603**



**Model A-F3605**



**Model A-F3606**



**Model A-F3615**



**Model A-F3619**



**Model A-F3620**



**Model A-F3620-C**  
Flat Mount for road racing bike



**Model A-F3621**



**Model A-F3623**  
Flat Mount for road racing bike



**Model A-F3624**  
Flat Mount for road racing bike



**E-thru A-F3625**



**Model A-F3626**



**Model A-F3627-A**  
Flat Mount for road racing bike



**Model A-F3630**



**Model A-F3631**  
Flat Mount for road racing bike



**Model A-F3631-A**  
Flat Mount



**Model A-F3642**



**Model A-F3643**  
E-Thru





A-F3167-0



A-F3190



A-F3200



A-F3200-1



A-F3200-1A



A-F3220-1



A-F3245-1



E-thru A-F3246



A-F3248



AUK-03



AUK-04



AF3633  
Kickstand



A-FCS01



A-FCS02



A-SB06



BOSCH Motor Bracket  
A1-22



SHIMANO  
Motor Bracket  
A1-24



BOSCH\_CX  
Motor Bracket  
A1-25



Brose Motor Bracket  
A1-26



BOSCH\_3  
Motor Bracket  
A1-27



SHIMANO E8000  
Motor Bracket  
A1-28



BOSCH-Active G3  
Motor Bracket  
A1-29



YAMAHA  
Motor Bracket  
A1-33



SHIMANO E6100  
Motor Bracket  
A1-36



BOSCH-Active G3  
Motor bracket  
A1-38



BOSCH-CX G4  
Motor bracket  
A1-39



A-HG001



A-HG002



A-HG003



A-HG005



A-HG006



A-HG009



A-HG010



A-HG011



A-HG012



A-HG013



A-HG013-4



A-HG014



A-HG015



A-HG017



A-HG018



A-HG020



A-HG022



A-HG023



A-HG026



A-HG027



A-HG029



A-HG033



A-HG036



A-HG038



A-HG039



A-HG041



A-HG043



A-HG045



A-HG049



A-HG051



A-HG056



A-HG057



A-HG058



A-HG059



A-HG060



A-HG061



A-HG062



A-HG063



A-HG068



A-HG069



A-HG072



A-HG075



A-HG078



Φ12x142心軸  
A-HG081



A-HG082



A-HG083



A-HG084



A-HG085



Φ12x142心軸  
A-HG087



Φ12x142心軸  
A-HG088



A-HG090



A-HG092



A-HG093



# 六哥股份有限公司 LIOW KO CO., LTD.

一廠 彰化縣花壇鄉永春村油車巷 80 弄 2 號

二廠 彰化縣花壇鄉長春村福德巷 26 號

**LIOW KO**



## FACTORY 1

No.2, Ai.80 Yu Chu Lane, Yung Chun Tsun, Hwatan, Changhua, Taiwan  
TEL:886-47-863546/ FAX:886-47-877058

## FACTORY 2

No.26, Fu De Lane, Chang Cun Tsun, Hwatan, Changhua, Taiwan  
TEL:886-47-872546/ FAX:886-47-863550



# LIOW KO

## ► TECHNOLOGY

模具設計及製造 Tooling Design & Manufacturing  
金屬鍛造 Metal Forging 3D  
3D 鍛抽 3D Forging & Extrusion



## ► FACILITY

電腦輔助設計 CAD/CAM System  
ABS 立體列印系統 3D ABS Mock Up  
鍛造機 (最大 4000T) Forging Machine Max.4000T  
沖壓機 Stamping Machine  
CNC 綜合加工機 CNC processing machine  
照像量測系統 High-Speed 3D Digitizer  
三次元座標量測儀 Coordinate Measuring Machine



**Make Customer designs come true!**  
**Hi-end quality by lowest cost!**





**CH-600TBW**  
UPPER 1-1/8", LOWER 1-1/2"  
Ø 28.6x44x49.7x39.8  
Material : Alloy(#1.2), Nylon(#B),  
Steel(#3.4.5)  
Type : Threadless, Cartridge  
Height : 9.2+11.2=20.4mm  
Weight : 206g



**CH-6381TBW**  
UPPER 1-1/8", LOWER 1-1/2"  
Ø 28.6x44x49.7x39.8  
Material : Alloy(#1), Nylon(#2,B),  
Steel(#3.4.5)  
Type : Threadless, Cartridge  
Height : 9+11.2=20.4mm  
Weight : 199g  
**CH-6382TBW -> #5: Ø30.0mm**



**CH-6201TBW**  
UPPER 1-1/8", LOWER 1-1/2"  
Ø 28.6x44x56x39.8  
Material : Alloy(#1.2), Nylon(#B),  
Steel(#3.4.5)  
Type : Threadless, Cartridge  
Height : 9.2+4=13.2mm  
Weight : 165g  
**CH-6201-1TBW -> #5: Ø30.0mm**



**CH-6202TEBW**  
UPPER 1-1/8", LOWER 1-1/2"  
Ø 28.6x44x56x39.8  
Material : Alloy(#1.2), Nylon(#B),  
Steel(#3.4.5)  
Type : Threadless, Sealed Bearing  
Height : 15+4=19mm  
Weight : 145g  
**CH-6202-1TEBW -> #5: Ø30.0mm**



**CH-6255TEBW**  
UPPER 1-1/8", LOWER 1-1/2"  
Ø 28.6x44x55x39.8  
Material : Alloy(#1), Nylon(#2,B),  
Steel(#3.4.5)  
Type : Threadless, Cartridge  
Height : 15+4=19mm  
Weight : 155g  
**CH-6256TEBW -> #5: Ø30.0mm**



**CH-903TBW**  
1-1/8"  
Ø 28.6x34x30  
Material : Nylon(#B,2-1,5-1),  
Alloy(#1), Steel(#2.3.4.5)  
Type : Threadless, Ball Retainer  
Height : 12+11=23mm  
Weight : 145g



**CH-664TBW**  
1"  
Ø 25.4x30x27  
Material : Alloy(#1), Nylon(#A-1,5-1),  
Steel(#A.2.3.4.5)  
Type : Threadless, Ball Retainer  
Height : 14.5+10.5=25mm  
Weight : 135g



**CH-6502TBW**  
UPPER 1-1/8", LOWER 1-1/2"  
Ø 28.6x41.8x52x39.8  
Material : Alloy(#1.2), Nylon(#B),  
Steel(#5)  
Type : Threadless, Sealed Bearing  
Height : 10.5+0.8=11.3mm  
Weight : 110g  
**CH-6502-1TBW -> #5: Ø30.0mm**



**CH-990TEBW**  
CARBON, 1-1/8"  
Ø 28.6x41.8x30  
Material : Carbon(#1.2), Nylon(#B),  
Steel(#5)  
Type : Threadless, Sealed Bearing  
Height : 10.5+0.8=11.3mm  
**CH-990TBW #2-> 8.6mm**  
**CH-990TEBW #2-> 15.8mm**  
**CH-990TBW #2-> 25.8mm**



**CH-988TBW**  
1-1/8" Ø 28.6x41.8x30  
Material : Alloy(#1.2), Nylon(#B),  
Steel(#5)  
Type : Threadless, Sealed Bearing  
**CH-988TBW #2-> 8.6mm**  
**CH-988TEBW #2-> 15.8mm**  
**CH-988TBW #2-> 25.8mm**



**CH-917TBW**  
1" Ø 25.4x41.4x26.4



**CH-918TEBW**  
1-1/8" Ø 28.6x44x30  
Material : Alloy(#1.2), Nylon(#B),  
Steel(#3.4.5)  
Type : Threadless, Cartridge  
Height : 17.5+3=20.5mm  
Weight : 148g



**CH-9280TBW**  
1-1/8" Ø 28.6x44x30  
Material : Alloy(#1), Nylon(#2,B),  
Steel(#3.4.5)  
Type : Threadless, Cartridge  
Height : 9.2+3=12.2mm  
Weight : 133g  
**CH-9280TEBW #2-> 15mm**  
**CH-9280TBW #2-> 20mm**  
**CH-9280TBW #2-> 30mm**



**CH-9200ATBW**  
1-1/8" Ø 28.6x44x30  
Material : Alloy(#1.2.3.4.2-1),  
Nylon(#B.5-1), Steel(#5)  
Type : Threadless, Sealed Bearing  
**CH-9200ATEBW #2-> 20mm**  
**CH-9200ATBW #2-> 30mm**



**CH-9072TBW**  
1", ROTATE 130°  
Ø 25.4x30x27  
Material : Alloy(#1.2), Rubber(#B),  
Steel(#3.4.5)  
Type : Threadless, Cartridge  
Height : 15+12.3=27.3mm  
Weight : 155g



**CH-201TCBW**  
1" Ø 25.4x30x27/30.2x26.4



**CH-208TBW**  
1" Ø 25.4x30x27/30.2x26.4



**CH-2050TW**  
1" Ø 25.4x30x27/30.2x26.4



**CH-207TBW**  
1" Ø 25.4x30x27/30.2x26.4



**CH-290TBW**  
1-1/8" Ø 28.6x34x30  
Material : Alloy(#1.2), Nylon(#B),  
Steel(#3.4.5)  
Type : Threadless, Cartridge  
Height : 13+10=23mm  
Weight : 132g

**CH-281TCBW**  
1-1/8" Ø 28.6x34x30  
Material : Alloy(#1), Nylon(#B),  
Steel(#2.3.4.5)  
Type : Threadless, Cartridge

**CH-288TBW**  
1-1/8" Ø 28.6x34x30  
Material : Alloy(#1.2), Nylon(#B),  
Steel(#3.4.5)  
Type : Threadless, Cartridge

**CH-2850TW**  
1-1/8" Ø 28.6x34x30  
Material : Alloy(#1.2.3.4), Nylon(#B),  
Steel(#5)  
Type : Threadless, Sealed Bearing

**CH-287TBW**  
1-1/8" Ø 28.6x34x30  
Material : Alloy(#1.2.3.4), Nylon(#B),  
Steel(#5)  
Type : Threadless, Sealed Bearing



HP162 HPA163 HPA182



HPA183 HP185 HP186



**CABLE CLIP, ABS**  
DSP3940E  
(For 1-1/8", use with CH-919BW)  
DSP664N



**DUST COVER, ABS**



ALLOY SPACER



**CH-919NEB**  
1-1/8"  
Ø 28.6x44x30

Material : Zn Alloy(#1,2), Nylon(#B), Steel(#3,4,5)  
Type : Thread, Cartridge  
Weight : 164g



**CH-600NBW**  
UPPER 1-1/8", LOWER 1-1/2"  
Ø 28.6x44x49.7x39.8

Material : Alloy(#B), Zn Alloy(#1,2), Steel(#A,3,4,5)  
Type : Thread, Cartridge  
Height : 9.2+11.2=20.4mm  
Weight : 257g



**CH-600BW**  
UPPER 1-1/8", LOWER 1-1/2"  
Ø 28.6x44x49.7x39.8

Material : Alloy(#1), Zn Alloy(#2), Steel(#A,3,4,5)  
Type : Thread, Cartridge  
Height : 9+11.2=20.4mm  
Weight : 242g



**CH-929NBW**  
1-1/8"  
Ø 28.6x44x30

Material : Alloy(#1), Zn Alloy(#2), Nylon(#B), Steel(#3,4,5)  
Type : Thread, Cartridge  
Height : 14.5+3=17.5mm  
Weight : 145g



**CH-9072BW**  
1", ROTATE 130  
Ø 22.2x30x27

Material : Zn Alloy(#1), Steel(#A,3,4,5) Steel+Plastic(#2)  
Type : Thread, Cartridge  
Height : 26+12.3=38.3mm  
Weight : 165g



**CH-917MBW**  
1" Ø 22.2x41.4x26.4

Material : Alloy(#1), Zn Alloy(#2) Steel(#3,4,5)  
Type : Thread, Cartridge  
Height : 18.7+3=21.7mm  
Weight : 132g



**CH-919BW**  
1-1/8" Ø 25.6x44x30

Material : Alloy(#1), Zn Alloy(#2) Steel(#3,4,5)  
Type : Thread, Cartridge  
Height : 18.7+3=21.7mm  
Weight : 146g



**CH-919MBW**  
1-1/8" Ø 25.6x44x30

Material : Alloy(#1), Zn Alloy(#2) Steel(#3,4,5)  
Type : Thread, Cartridge  
Height : 18.7+3=21.7mm  
Weight : 140g



**CH-919NBW**  
1-1/8" Ø 25.6x44x30

Material : Alloy(#B), Zn Alloy(#1,2) Steel(#A,3,4,5)  
Type : Thread, Cartridge  
Height : 18+3=21mm  
Weight : 142g



**CH-920AMBW**  
1-1/8" Ø 25.6x44x30

Material : Alloy(#1,3,4), Zn Alloy(#2), Steel(#A,5)  
Type : Thread, Sealed Bearing  
Height : 18.7+3=21.7mm  
Weight : 109g



**CH-290BW**  
1-1/8" Ø 25.6x34x30

Material : Zn Alloy(#1), Steel(#2,3,4,5)  
Type : Thread, Cartridge  
Height : 24.5+10=34.5mm  
Weight : 120g



**CH-2900BW**  
1-1/8" Ø 25.6x34x30

Material : Zn Alloy(#1), Steel(#2,3,4,5)  
Type : Thread, Cartridge  
Height : 25.2+10=35.2mm  
Weight : 152g



**CH-903BW**  
1-1/8" Ø 25.6x34x30

Material : Zn Alloy(#1), Steel(#2,3,4,5)  
Type : Thread, Ball Retainer  
Height : 24+11=36mm  
Weight : 148g



**CH-9080MBW**  
1-1/8" Ø 25.6x34x30

Material : Alloy(#1), Steel(#2,3,4,5)  
Type : Thread, Cartridge  
Height : 26+10.5=36.5mm  
Weight : 180g



**CH-101ABW**  
1" Ø 22.2x30x27/30.2x26.4  
Height : 27+10.2=37.2mm  
Weight : 138g

**CH-181ABW**  
1-1/8" Ø 25.6x34x30  
Height : 26.5+10.5=37mm  
Weight : 160g

Material : Alloy(#1,2), Steel(#A,3,4,5)  
Type : Thread, Cartridge



**CH-105AW**  
1" Ø 22.2x30x27/30.2x26.4  
Height : 25+12.2=37.2mm  
Weight : 110g

**CH-185AW**  
1-1/8" Ø 25.6x34x30  
Height : 24.5+12.5=37mm  
Weight : 124g

Material : Alloy(#1,2,3,4), Steel(#A,5)  
Type : Thread, Sealed Bearing



**CH-106AW**  
1" Ø 22.2x30x27/30.2x26.4  
Height : 27.5+10.8=38.3mm  
Weight : 85g

**CH-186AW**  
1-1/8" Ø 25.6x34x30  
Height : 27.5+10.8=38.3mm  
Weight : 97g

Material : Alloy(#1,2,3,4), Steel(#A,5)  
Type : Thread, Sealed Bearing



**CH-601**  
1", BMX Ø 21.2x32.5x27

Material : Zinc Alloy(#1), Steel(#A,2,3,4,5)  
Type : Thread, Ball Retainer  
Height : 24+11.5=35.5mm  
Weight : 162g



**CH-605**  
1", BMX Ø 21.2x32.5x27

Material : Zinc Alloy(#1), Steel(#A,2,3,4,5)  
Type : Thread, Ball Retainer  
Height : 24.5+11.5=36mm  
Weight : 178g



**CH-605BW**  
1", BMX Ø 21.2x32.5x27

Material : Zinc Alloy(#1), Plastic(#B) Steel(#A,2,3,4,5)  
Type : Thread, Ball Retainer  
Height : 27.5+11.5=39mm  
Weight : 190g



# Threading Is Always Better Trust T47



**M4768P**

- Available for BB Shell Width 68–73mm & Spindle 30mm
  - M47 X P1.0
  - Alloy Adapters & Nylon Sleeve
- M4768E** (W/O Sleeve)



**M4786P (External)**

- Available for BB Shell Width 68–73mm & Spindle 30mm
  - M47 X P1.0
  - Alloy Adapters & Nylon Sleeve
- M4786SP** (Spindle 24mm)  
**M4786RP** (Spindle 24/22mm)



**M4786S (External/Shimano)**  
**M4786R (External/SRAM)**

- Available for BB Shell Width 68–73mm & Spindle 24/22mm
  - M47 X P1.0
  - Alloy Adapters & Sleeve
- M4786ES / M4786ER** (W/O Sleeve)



**M47S (External/Shimano)**  
**M47R (External/SRAM)**

- Available for BB Shell Width 68–73mm & Spindle 24/22mm
  - M47 X P1.0
  - Alloy Adapters & Sleeve
- M47ES / M47ER** (W/O Sleeve)



**G32**

- Eccentric BB
- Available for BB Shell I.D. 46mm & Width 68–73mm
- JIS BB Only



**GP30**

- For BB Shell I.D. 46mm & Width 68–86.5mm
- Internal Thread Fixing Structure



**G92S (Shimano)**  
**G92R (SRAM)**

- For BB Shell I.D. 41mm & Width 86.5–92mm
- Internal Thread Fixing Structure



**GF24S (Shimano)**  
**GF24R (SRAM)**

- For BB Shell I.D. 46mm & Width 86mm
  - Alloy Adapters
  - Angular Contact Thrust Bearings
- GF24ES/GF24ER** (W/O Sleeve)



**G301A**

IS42/28.6 | IS52/40



**G507A**

IS42/28.6 | IS42/30



**G508A**

ZS44/28.6 | ZS56/40



**D345A**

ZS44/28.6 | ZS55/40



**D544S**

ZS44/28.6 | ZS44/30



**CS3-4**

ZS44/28.6 | EC44/40



**D510A**

EC34/28.6 | EC34/30

## Tapered Angle Limited Headsets





www.fpd-fasten.com.tw

豐德興業股份有限公司 FPD INDUSTRY CORP.

台中市烏日區五光路189巷136號

No.136, Ln. 189, Wuguang Rd., Wurih Dist., Taichung City 41470, Taiwan

TEL : +886 4 23389808 FAX : +886 4 23382807 E-mail : fpd@fpd-fasten.com.tw

豐德精密實業(深圳)有限公司 FASTEN PRODUCTS MFG LTD.

中國深圳寶安區沙井鎮大王山第三工業區

3Rd., Industrial Zone, Da Wang Shan Village Shajing Town, Bao'an County, Shenzhen, China

TEL : +86-755-3366-8388 FAX : +86-755-3366-8996 E-mail : fpdinf@fpdfasten.com

漳浦緯柏自行車有限公司 FASTEN PRODUCTS MFG(XIAMEN) LTD.

中國福建省漳州市漳浦縣縣鎮舊鎮工業園

Jiuzhen Industrial Zone, Jiuzhen Town, Zhangpu County, Zhangzhou City, Fujian, China

TEL : +886-596-3921360 FAX : +886-596-3921365 E-mail : fpdinf@fpdfasten.com

Licensed by KORE Component for OEM headset manufacture

## CHEX-1089

Upper : 1-1/8" / Steel cup / Ball Retainer  
Bottom : 1-1/8" / Steel cup / Ball Retainer  
W/O Top Cover  
Stack Height 4.5 + 3.6 = 8.1mm



XS44/28.6-ZS44/30

## CHEX-1286A

Upper : 1-1/8" / Alloy cup / Sealed Bearing  
Bottom : 1-1/8" / Alloy cup / Sealed Bearing  
w/ 5.5mm Alloy Top Cover  
Stack Height 7.2 + 6.1 = 13.3mm  
CHEX-1286B  
w/8mm Alloy Top Cover, S.H.=15.8mm  
CHEX-1286C  
w/15mm Alloy Top Cover, S.H.=22.8mm



XS44/28.6-ZS44/30

## DOZER-1048A

Upper : 1-1/8" / Steel cup / Ball Retainer  
Bottom : 1-1/2" / Steel cup / Ball Retainer  
w/ 15mm Alloy Top Cover  
Stack Height 18.5 + 2.7 = 21.2mm  
DOZER-1048B  
w/ 8mm Alloy Top Cover S.H.=13.7mm  
DOZER-1048A-NY  
w/ 15mm Nylon Top Cover



ZS 44/28.6 - ZS 56/39.8

## DOZER-1066A

Upper : 1-1/8" / Sealed Bearing  
Bottom : 1-1/2" / Sealed Bearing  
w/ 15mm Alloy Top Cover / OD 46mm  
Stack Height 15.7 + 1 = 16.7mm  
DOZER-1066A-1  
w/ 30mm alloy Crown Race  
DOZER-1066B  
w/ 8mm Alloy Top Cover, S.H.=9.7mm  
DOZER-1066AF-08  
w/ Semi-Cartridge



IS 42/28.6 - IS 52.2/39.8

## IGA-1080A

Upper : 1-1/8" / Semi-Cartridge  
Bottom : 1-1/8" / Semi-Cartridge  
w/ 15mm Alloy Top Cover / OD 46mm  
Stack Height 15.7 + 1 = 16.7mm  
IGA-1080B  
w/ 8mm Alloy Top Cover, S.H.=9.7mm  
IGA-1080A-NY  
w/ 15 Nylon Top Cover



IS 41.2/28.6 - IS 41.2/30  
Bearing 45 x 45

## DOZER-1146A

Upper : 1-1/8" / Sealed Bearing  
Bottom : 1-1/4" / Sealed Bearing  
w/ 15mm Alloy Top Cover / OD 46mm  
Stack Height 15.3 + 1 = 16.3mm  
DOZER-1146A-NY  
w/15mm Nylon Top Cover / OD 45mm  
DOZER-1346A  
w/15mm Alloy Top Cover / OD 47mm  
DOZER-1246A  
w/ Semi-Cartridge



IS 42/28.6 - IS 47/33

## STS-1086A

Upper : 1-1/8" / Alloy cup / Sealed Bearing  
Bottom : 1-1/8" / Alloy cup / Sealed Bearing  
w/ 5.5mm Alloy Top Cover  
Stack Height 15.5 + 12.7 = 28.2mm



EC 34/28.6 - EC 34/30

## K-886

Upper : 1-1/8" / Alloy cup / Sealed Bearing / For ID 34mm Head Tube  
Bottom : 1-1/8" / Alloy cup / Sealed Bearing / For ID 34mm Head Tube  
w/ 10.6mm ABS Top Cover  
Stack Height 27 + 12 = 39mm



## CHEX-1189A

Upper : 1-1/8" / Steel cup / Ball Retainer  
Bottom : 1-1/8" / Steel cup / Ball Retainer  
15mm Alloy Top Cover  
Stack Height 17.7 + 4.0 = 21.7mm  
CHEX-1189B-NY  
w/ 8mm Nylon Top Cover, S.H.=14.2mm  
CHEX-1189A-NY  
w/15mm Nylon Top Cover, S.H.=21.7mm  
CHEX-1189B  
w/8mm Alloy Top Cover, S.H.=14.2mm

## DOZER-1045A

Upper : 1-1/8" / Steel cup / Z-type Bearing  
Bottom : 1-1/4" / Alloy cup / Sealed Bearing  
w/ 11.2mm Alloy Top Cover  
Stack Height 12.7 + 3 = 15.7mm  
DOZER-1045B  
w/8mm Alloy Top Cover S.H.= 12.5mm  
DOZER-1045C  
w/15mm Alloy Top Cover S.H.=19.5mm

## DOZER-1861A

Upper : 1-1/8" / Steel cup / Z-type Bearing  
Bottom : 1-1/2" / Steel cup / Z-type Bearing  
w/ 15mm Alloy Top Cover  
Stack Height 17.7 + 3.9 = 21.6mm  
DOZER-1861A-NY  
w/ 15mm Nylon Top Cover

## DOZER-1568A

Upper : 1-1/8" / Semi-Cartridge  
Bottom : 1-1/2" / Semi-Cartridge  
w/ 15mm Alloy Top Cover / OD 46mm  
Stack Height 15.7 + 1 = 16.7mm  
DOZER-1568B  
w/ 8mm Alloy Top Cover, S.H.=9.7mm

## IGA-1156A

Upper : 1" / Sealed bearing  
Bottom : 1" / Sealed bearing  
w/ 8mm Alloy Top Cover / OD 42mm  
Stack Height 8.7 + 1 = 9.7mm

## STS-1389

Upper : 1-1/8" / Alloy cup / Ball Retainer  
Bottom : 1-1/8" / Alloy cup / Ball Retainer  
W/O Top Cover  
Stack Height 13 + 12.5 = 25.5mm

## STS-1059A

Upper : 1" / ID 30.2mm / Steel cup / Ball Retainer  
Bottom : 1" / ID 30.2mm / Steel cup / Ball Retainer  
W/O Top Cover  
Stack Height 11.5 + 10.5 = 22mm  
STS-1059B  
w/ 27.0mm crown race

## K-103

Upper : 1" / Steel cup / Z-type Bearing / For ID 41.4mm Head Tube  
Bottom : 1" / Steel cup / Z-type Bearing / For ID 41.4mm Head Tube  
w/ 4mm ABS Top Cover  
Stack Height 21 + 2.8 = 23.8mm  
K-803  
Upper : 1-1/8" / Steel cup / Z-type Bearing / For ID 44mm Head Tube  
Stack Height 21 + 3 = 24mm



XS44/28.6-ZS44/30



XS44/28.6-ZS49.7/33



ZS 44/28.6 - ZS 56/39.8



IS 42/28.6 - IS 52.2/39.8



IS 38.2/25.4 - IS38.2/26.4  
Bearing 36 x 45



EC 34/28.6 - EC 34/30



EC 30/26.4 - EC 30/26.4



## CHEX-1288D

Upper : 1-1/8" / Steel cup / Z-type Bearing  
Bottom : 1-1/8" / Steel cup / Z-type Bearing  
w/ 8mm Alloy Top Cover  
Stack Height 10.7 + 4.0 = 14.7mm



XS44/28.6-ZS44/30

## DOZER-1366A

Upper : 1-1/8" / Alloy cup / Sealed Bearing  
Bottom : 1-1/2" / Alloy cup / Sealed Bearing  
w/ 15mm Alloy Top Cover  
Stack Height 17.7 + 3 = 20.7mm  
DOZER-1366A-1  
w/ 39.8mm crown race  
DOZER-1366D  
w/ 8mm Alloy Top Cover, S.H.=13.7mm  
DOZER-1366AWF-2  
w/ Semi-Cartridge



ZS 44/28.6 - ZS 55/39.8

## DOZER-1267A

Upper : 1-1/8" / Alloy cup / Sealed Bearing  
Bottom : 1-1/2" / Alloy cup / Sealed Bearing  
w/ 18.5mm Alloy Top Cover  
Stack Height 18 + 3.0 = 21.0mm



ZS 44/28.6 - ZS 56/30

## IGA-1086A

Upper : 1-1/8" / Sealed Bearing  
Bottom : 1-1/8" / Sealed Bearing  
w/ 7.5mm Alloy Top Cover / OD: 45mm  
Stack Height 8.2 + 1 = 9.2mm  
IGA-1086B-NY  
w/15mm Nylon Top Cover  
IGA-1086C  
w/15mm Alloy Top Cover, S.H.=16.7mm  
IGA-1086-B099  
w/B09 Bearing



ZS44/28.6-ZS44/30

## IGA-1150A

Upper : 1" / Semi-cartridge  
Bottom : 1" / Semi-cartridge  
w/ 8mm Alloy Top Cover / OD 42mm  
Stack Height 8.7 + 1 = 9.7mm



IS 38.2/25.4 - IS38.2/26.4  
Bearing 36 x 45

## STS-1489

Upper : 1-1/8" / Steel cup / Ball Retainer  
Bottom : 1-1/8" / Steel cup / Ball Retainer  
W/O Top Cover  
Stack Height 11 + 10.5 = 21.5mm  
STS-1489A  
w/ 15mm Alloy Top Cover, S.H.=34.7mm  
STS-1489A-NY  
w/ 15mm Nylon Top Cover, S.H.=34.7mm



EC 34/28.6 - EC 34/30

## K-102

Upper : 1" / Steel cup / Z-type Bearing / For ID 30mm Head Tube  
Bottom : 1" / Steel cup / Z-type Bearing / For ID 30mm Head Tube  
w/ 10.3mm ABS Top Cover  
Stack Height 26 + 10.2 = 36.2mm  
K-802



Upper : 1-1/8" / Steel cup / Z-type Bearing / For ID 34mm Head Tube  
w/ 9.7mm ABS Top Cover  
Stack Height 28.5 + 11.4 = 39.9mm

## K-806

Upper : 1-1/8" / Steel cup / Ball Retainer / For ID 34mm Head Tube  
Bottom : 1-1/8" / Steel cup / Ball Retainer / For ID 34mm Head Tube  
W/O Top Cover  
Stack Height 25.5 + 10 = 35.5mm





## HC-02 POWER ANCHOR

Expander Headset



## EP-02M POWER PLUGS

Handlebar End Plugs



6061 T6 Aluminum  
For Mountain Bike  
Torque is : 2~4N~m  
(20~40kgf-cm)  
Weight : 13 g / pc.

## EP-02R POWER PLUGS

Handlebar End Plugs



6061 T6 Aluminum  
For Road Bike  
Torque is : 2~4N~m  
(20~40kgf-cm)  
Weight : 13g / pc.

## CA-01 POWER MACARONI

Cable Adaptor

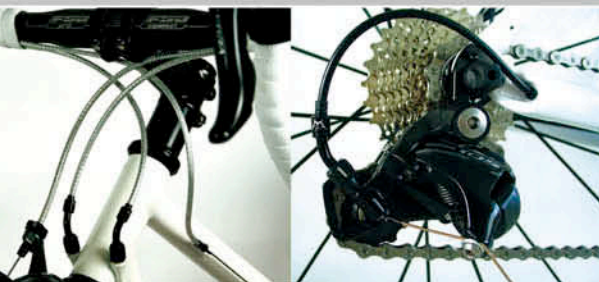

6063 Aluminum  
Weight : 2.5 g / pc.

## HC-02 POWER ANCHOR

Expander Headset

### HC-02A Series



Colors available ● ● ●

### HC-02P



New design wedge mechanism  
6061 T6 aluminum alloy (HC-02A)  
Nylon PA6 (HC-02P)  
Quick and easy fitting  
Removable and reusable  
For carbon fiber / aluminum / steel fork tube  
Fits 1 1/8" (28.6mm OD x 23.5~25.5mm ID) Steerer  
Fitting notice : Best screw fitting  
Torque is : 4~6 N-m (40~60 kgf-cm)  
Extreme light weight : 13 g / pc.

### HC-CS (Cap & Screw)



HC-CS00  
Aluminum top cap  
Weight : 17 g / set

HC-CS01  
Aluminum top cap  
100% CNC  
Weight : 15 g / set

HC-CS02  
Carbon UD top cap  
Titanium screw  
Weight : 10 g / set

## SC-01 POWER VISE

Seat Clamp

6061 T6 aluminum alloy 100% CNC 4th axle machined body  
Stainless steel hardware



Ø31.8mm x Ø27.2mm  
47.5g / pc



Ø34.9mm x Ø31.6mm  
52 g / pc



## BC-01AP POWER WING

Bottle Cage

Austria made 6061 T6 aluminum alloy  
Stainless steel hardware  
Weight : 35 g / pc.



# bikenews\_online

**For Those Who Want to Keep Up With the Race.**

www.bikenews.online features the newest and most important information on the bicycle industry. It covers the latest bike industry and market trends, as well as upcoming events and new products. In the fast-moving and competitive world of cycling, visit us to remain ahead of the race.



## What's New

Latest news from global bike markets

## TBS

Taiwan Bicycle Source 2018-2019 + Search Engine

## eBook Download

TBS & CBES & BMU

## Bike & E-Bike Market Update (BMU)

## CBES

China Bicycle & E-Bike Top Suppliers 2018-2019

## Free e-newsletter



 輪彥國際有限公司  
**WHEEL GIANT INC.**  
 軟實力傳媒有限公司  
**Soft Power Media Co., Ltd.**

No. 193, Tzu-Chiang Rd., Changhua 50095, Changhua, Taiwan  
Tel: 886-4-7350500, 7360794~5 Fax: 886-4-7357860  
E-mail: rep@mail.wheelgiant.com.tw Website: www.bikenews.online  
Shanghai Tel: 86-512-57515789 Tianjin Tel: 86-22-28137963  
Ningbo Tel: 86-574-88210669 Shenzhen Tel: 86-755-28069189



# neco

Professional Bike  
Parts Manufacturers

NECO TECHNOLOGY INDUSTRY CO., LTD

www.necoparts.com



### H373G

HEIGHT 9.1 ± 1mm  
 WEIGHT 87g  
 FINISH Silver, Black  
 SIZE 1.5" Head tube Reduced to 1-1/8" Fork tube Threadless Headset  
 DIMENSIONS 1-1/8" x42x52.2x39.8  
 MATERIAL 6061/T6 CNC Machined Top Cover Steel Crown Race  
 SHIS NORM 42/28.6 | 52.2/39.8(30)



### H373-B52

HEIGHT 9.5 ± 1mm  
 WEIGHT 80g  
 FINISH Silver, Black  
 SIZE 1.5" Head tube Reduced to 1-1/8" Fork tube Threadless Headset  
 DIMENSIONS 1-1/8" x42x52.2x39.8  
 MATERIAL 6061/T6 CNC Machined Top Cover 7075/T6 CNC Machined Crown Race  
 SHIS NORM 42/28.6 | 52.2/39.8(30)



### H373

HEIGHT 9.7 ± 1mm  
 WEIGHT 80g  
 FINISH Silver, Black  
 SIZE 1.5" Head Tube Reduced to 1-1/8" Fork Tube Threadless Headset  
 DIMENSIONS 1-1/8" x42x52.2x39.8  
 SEAL BEARING NHB-6B & NHB-1 5  
 MATERIAL 6061/T6 CNC Machined Top Cover 7075/T6 CNC Machined Crown Race  
 SHIS NORM IS42/28.6 | IS52.2/39.8 IS42/28.6 | IS52.2/30.0



### H373S

HEIGHT 9.4 ± 1mm  
 WEIGHT 83.6g  
 FINISH Silver, Black  
 SIZE 1.5" Head Tube Reduced to 1-1/8" Fork Tube Threadless Headset  
 DIMENSIONS 1-1/8" x42x52.2x39.8  
 BALL BEARING CR-MO Steel (OD41.8x45°45°)  
 MATERIAL 6061/T6 CNC Machined Top Cover 7075/T6 CNC Machined Crown Race  
 SHIS NORM IS42/28.6 | IS52.2/39.8 IS42/28.6 | IS52.2/30.0



### H397

HEIGHT 9.5 ± 1mm  
 WEIGHT 76g  
 FINISH Silver, Black  
 SIZE 1.5" Head Tube Reduced to 1-1/8" Fork Tube Threadless Headset  
 DIMENSIONS 1-1/8" x42x52x39.8  
 SEAL BEARING NHB-6B & ACB518K  
 MATERIAL 6061/T6 CNC Machined Top Cover 7075/T6 CNC Machined Crown Race  
 SHIS NORM IS42/28.6 | IS52.2/39.8 IS42/28.6 | IS52.2/33.0



### H51

HEIGHT 9.4 ± 1mm  
 WEIGHT 65g  
 FINISH Silver, Black  
 SIZE 1-1/8" Integrated Headset Campy Compatible  
 DIMENSIONS 1-1/8" x 42 x 30  
 SEAL BEARING NHB-6B (OD41.8x45°x45°)  
 MATERIAL 6061/T6 CNC Machined Top Cover 7075/T6 CNC Machined Crown Race  
 SHIS NORM IS42/28.6 | IS42/30.0



### H52

HEIGHT 9.4 ± 1mm  
 WEIGHT 74g  
 FINISH Silver, Black  
 SIZE 1-1/8" Integrated Headset Campy Compatible  
 DIMENSIONS 1-1/8" x42x46x30  
 SEAL BEARINGS CBB-418  
 MATERIAL 6061/T6 CNC Machined Top Cover Steel Crown Race  
 SHIS NORM 42/28.6 | 42/30



### H100

HEIGHT 8.7 ± 1mm  
 WEIGHT 123g  
 FINISH Silver, Black  
 SIZE 1-1/4" Head Tube Reduced to 1-1/8" Fork Tube Semi-Integrated Threadless Headset  
 BALL BEARING Ball-Retainer Type  
 MATERIAL Steel Top Cover & Cups  
 SHIS NORM ZS44/28.6 | ZS50.6/30(33)



### H383

HEIGHT 9.5 ± 1mm  
 WEIGHT 106g  
 FINISH Silver, Black  
 SIZE 1.5" Head Tube Reduced to 1-1/8" Fork Tube Semi-Integrated Threadless Headset  
 DIMENSIONS 1-1/8" x44/50x55/61x39.8  
 BALL RETAINER NHB-5D & NHB-15  
 MATERIAL 6061/T6 CNC Machined Top Cover & Upper Cup, Steel Lower Cup & Crown Race  
 SHIS NORM ZS44/28.6 | ZS55/39.8



### H385

HEIGHT 9.5 ± 1mm  
 WEIGHT 97g  
 FINISH Silver, Black  
 SIZE 1.5" Head Tube Reduced to 1-1/8" Fork Tube Semi-Integrated Threadless Headset  
 DIMENSIONS 1-1/8" x44/50x55/61x39.8  
 SEAL BEARING NHB-5D & NHB-15  
 MATERIAL 6061/T6 CNC Machined Top Cover & Cups, 7075/T6 CNC Machined Crown Race  
 SHIS NORM ZS44/28.6 | ZS55/39.8



### H146

HEIGHT 9.1 ± 1mm  
 WEIGHT 77.8g  
 FINISH Silver, Black  
 SIZE 1-1/8" Semi-Integrated Threadless Headset  
 DIMENSIONS 1-1/8" x44x50x30  
 SEAL BEARING NHB-5D  
 MATERIAL 6061/T6 CNC Machined Top Cover 7075/T6 CNC Machined Crown Race  
 SHIS NORM 44/28.6 | 44/30



### H148

HEIGHT 9.9 ± 1mm  
 WEIGHT 106g  
 FINISH Black or CP Cups, With Black or Silver Cups  
 SIZE 1-1/8" Semi-Integrated Threadless Headset w/ Ø44 Semi-Cartridge Steel Cups  
 DIMENSIONS 1-1/8" x 44/50 x 30  
 BALL RETAINER 5/32"x22x2pcs  
 MATERIAL 6061/T6 CNC Machined Top Cover Steel Cups & Crown Race  
 SHIS NORM ZS44/28.6 | ZS44/30.0



# neco

Professional Bike  
Parts Manufacturers

NECO TECHNOLOGY INDUSTRY CO., LTD

www.necoparts.com



## H128N

HEIGHT 25 ± 1mm  
 WEIGHT 153g  
 FINISH CP, Black  
 SIZE 1-1/8" Semi-Integrated  
 Threadless Headset  
 DIMENSIONS Ø25.4 x 44 x 30  
 BALL RETAINER 5/32"x22x2pcs  
 MATERIAL Full Set Steel



## H112N

HEIGHT 25 ± 1mm  
 WEIGHT 171g  
 FINISH Black or CP Cups, With Black or Silver Cups  
 SIZE 1-1/8" Semi-Integrated  
 Threaded Headset  
 w/ Ø44 Steel Cups  
 DIMENSIONS Ø25.4 x 44/50 x 30  
 BALL RETAINER 5/32"x22x2pcs  
 MATERIAL Full Set Steel w/ Alloy Cover



## H156

HEIGHT 11.8± 1mm  
 WEIGHT 134g  
 FINISH Black or CP Cups, With Black or Silver Cups  
 SIZE 1.5" Head Tube Reduced to 1-1/8" Fork Tube  
 Semi-Integrated Threadless Headset  
 Standard For:  
 5mm Height Alloy Cover  
 Upper Cups Insert Dia.44mm  
 Lower Cups Insert Dia.55mm  
 1-1/8" Straight Fork Steerer Ø30mm  
 Fork Crown-Race  
 BALL RETAINER Semi Cartridge Ball-Retainer Type  
 MATERIAL Full Steel, w/Alloy Cover  
 SHIH NORM ZS44/28.6 | ZS55/30.0



## H151S

HEIGHT 20.2 ± 1mm  
 WEIGHT 119g  
 FINISH Silver, Black  
 SIZE 1-1/8" to 1.5" Tapered Fork  
 Threadless Headset  
 DIMENSIONS Standard For : 5mm Alloy Cover  
 Upper Cups Insert Dia.44mm  
 Lower Cups Insert Dia.44mm  
 1.5" - 1-1/8" Taper Fork Steerer  
 Ø39.8mm Fork Crown-Race  
 NHB-5D & NHB-15  
 Full Alloy  
 SHIS NORM ZS44/28.6 | EC44/39.8



## H153BW

HEIGHT ± 1mm  
 WEIGHT 194g  
 FINISH Silver, Black  
 SIZE 1-1/8" Threadless Headset  
 DIMENSIONS 1-1/8"x49.7x30  
 SEAL BEARING NHB-15 (OD52x45"x45")  
 MATERIAL Alloy Top Cover & Cups,  
 Stainless Crown Race



## H282 OPTIONAL: H282O

HEIGHT 29 ± 1mm  
 WEIGHT 95g  
 FINISH Silver, Black  
 SIZE 1-1/8" Threadless Headset  
 DIMENSIONS 1-1/8"x34x30  
 SEAL BEARING NHB-6B (OD Ø41.8x45"x45")  
 MATERIAL 6061/T6 CNC Machined Top Cover,  
 7075/T6 CNC Machined Crown Race  
 OPTIONAL:  
 H282O 1-1/8"x34x30  
 Height: 27 ± 1mm



## H773

HEIGHT 29± 1mm  
 WEIGHT 102g  
 FINISH Silver, Black  
 SIZE 1-1/8" Threadless Headset  
 DIMENSIONS 1-1/8"x34x30  
 SEAL BEARING NHB-6B (OD Ø41.8x45"x45")  
 MATERIAL 6061/T6 CNC Machined  
 Top Cover,  
 7075/T6 CNC Machined  
 Crown Race



## H878

HEIGHT 26.5 ± 1mm  
 WEIGHT 142g  
 FINISH CP, Black  
 SIZE 1-1/8" Threadless Headset  
 DIMENSIONS 1-1/8"x34x30  
 BALL RETAINER 5/32"x22x2pcs  
 MATERIAL Full Set in Steel



## NECO 3

WEIGHT 195g (Aluminum & Rubber Cover+  
 Components+Charger)  
 FINISH Black or Purple  
 OUTPUT 5V / 1A  
 CHARGER 3000 mAh  
 DIMENSION 92.5mm x Ø20mm  
 APPLICATION Head Tube w/ inner diameter  
 Ø22.8mm-Ø26mm



## NECO 1 (H299-1)

HEIGHT 32.8 ± 1mm  
 WEIGHT 153g  
 FINISH Silver, Black  
 SIZE 1-1/8" - 1/5" Front Fork Tube  
 DIMENSIONS 1-1/8"x44 / 50x56 / 62x30  
 BALL RETAINER Upper: Semi-Cartridge Ball Retainer  
 SHIS NORM ZS44/28.6 | ZS56/30.0



**TANGESEIKI**

value through technology

**TANGE SEIKI JAPAN**

Sakai, Osaka, Japan

TEL +816-4-23580100

**TANGE SEIKI TAICHUNG**

Taichung Taiwan

FAX +886-4-23580669

**TANGESEIKI SHENZHEN**

Shenzhen, Guangdong, China

www.tangeseiki.com

info@tangeseiki.com

## Technoglide Classic

CNC precision machined to very tight tolerances for ultimate performance and wear. A7075-T6 super light alloy with **fully sealed stainless steel cartridge bearing** and crown race. Threaded and threadless models. 1-1/8" and 1". Colors: Black, Silver, Blue, Red



Technical Specification	Size	model#	L1	L2	Stack Height	Weight
Technoglide Classic Threadless	1"	TG32	13.0	12.0	25.0mm	92g
Technoglide Classic Threaded	1"	TG32D	22.0	12.0	34.0mm	101g
Technoglide Classic Threadless	1-1/8"	TG36	15.0	13.5	28.5mm	97g
Technoglide Classic Threaded	1-1/8"	TG36D	23.3	13.5	36.8mm	105g

## Technoglide J-62

Super light Hybrid Cartridge Bearing on upper unit. Tange Seiki original designed 4T5 Cartridge Bearing on lower unit. Tange seiki exclusive **EZ system** on upper unit. Drilled non-structural areas for reduced weight.



Technical Specification	Size	model#	L1	L2	Stack Height	Weight
Technoglide J-62	1-1/8"	TG36J62	14.0	12.2	26.2mm	66.8g

## Technoglide J-2

CNC precision machined light alloy with super smooth Tange Seiki 4T5 **fully sealed cartridge bearing**. Tange Seiki exclusive **EZ system** on upper unit. **Long Insertion** design protects against head tube deformation and more durable wear. Threadless only. 1-1/8" and 1". Colors: Black, Silver



Technical Specification	Size	model#	L1	L2	Stack height	Weight
Technoglide J-2	1"	TG32J2	13.5	11.5	25.0mm	72g
Technoglide J-2	1-1/8"	TG36J2	14.0	11.5	25.5mm	88g

## Technoglide IS245LT

Lightweight and strong Duraluminum light alloy construction Fully Sealed Mechanism Campy sized 1-1/8" Cartridge Bearing upper Tange Seiki Original sized 4T5 1.5" Cartridge Bearing lower



Technical Specification	Size	model#	L1	L2	Weight
Technoglide IS245LT	1-1/8" / 1.5"	TGIS245LT	15/20/25	0.5	Taiwan Bicycle Source 2018-2019

## Technoglide ZS22

Lightweight and strong Duraluminum light alloy construction Fully Sealed Mechanism Tange Seiki Original sized 4T5 Cartridge Bearing 1" and 1-1/8" size available Silver or Black anodizing color available



Technical Specification	Size	model#	L1	L2	Stack height	Weight
Technoglide ZS22	1"	TG32ZS2	6.7	2.2	8.9mm	75g
Technoglide ZS22	1-1/8"	TG36ZS2	6.5	2.3	8.8mm	84g

## Technoglide ZS225X

Lightweight and strong duraluminum construction Tange Seiki original sized 4T5 Cartridge Bearing Upper Tange Seiki original sized 1.5" Cartridge Bearing Lower Straight 1-1/8" head tube with Tapered Fork (1-1/8" / 1.5")



Technical Specification	Size	model#	L1	L2	Stack height	Weight
Technoglide ZS225X	1-1/8" / 1.5"	TGZS225X	6.5	13.6	20.1mm	108g



**TANGESEIKI**  
value through technology



## LEVIN-CDS

CNC Machined Fully Cr-Mo construction  
Fully sealed Mechanism  
Super Stone Polish on every ball races



## LEVIN NJS Approved model

Tange Seiki Traditional Headset  
CNC Machined Fully Cr-Mo construction  
Super Stone Polish on every ball races



Technical Specification Size model# L1 L2 Stack height Weight  
Levin-CDS 1" LV-CDS 22.1 11.2 33.3mm 145g

## Falcon FL250C

Lightweight and strong duraluminum alloy construction  
Tange Seiki Original sized 4T5 Cartridge Bearings  
Fully Sealed Mechanism  
1" and 1-1/8" sized available



Technical Specification Size model# L1 L2 Stack height Weight  
Levin 1" LV-11 25.5 12.4 37.9mm 155g

## Bottom Brackets

### LN-7610SP

Fully CNC Machined Cr-Mo Hollow ISIS spline axle  
CNC Machined Light alloy cups and body  
108, 113 and 118mm axle length for 68 and 73mm shell width



### LN-7911

CNC Machined Light Alloy cups and body  
For X-Type crank set, and 68 or 73mm shell width



### LN-7922

Fully Machined Cr-Mo Hollow axle  
Light alloy cups and body  
68 and 73mm shell width  
Every sizes axle available



### LN-3922

Forged Steel Solid axle  
Steel CP cups and body  
68 and 73mm shell width  
Every sizes axle available



### LEN-3912

Forged Steel Solid axle  
Steel Black EDP cups and body  
68 and 73mm shell width  
Every sizes axle available



### LN-3912C

Forged Steel Solid or Nut type axle  
Steel Black EDP cups and body  
68 and 73mm shell width  
Every sizes axle available



Technical Specification Size model# L1 L2 Stack height Weight  
Falcon FL250C 1" FL250C 24.0 11.3 35.3mm 93g  
Falcon FL270C 1-1/8" FL470C 23.0 11.5 34.5mm 95g

## HUB

### HBRF-1001

Spoke Hole: 14Gx16H / 14Gx20H  
Axle Dim: 9(ID5.2)x100x108  
Axle Material: A7075-T6  
2 Sealed Bearings  
Weight: 105g



### HBRR-1001

Spoke Hole: 14Gx20H / 14Gx24H  
Axle Dim: 10(ID5.2)x130x140  
Axle Material: A7075-T6  
4 Sealed Bearings  
Weight: 240g



Shell Width	JL	JR	CL	L
68	17	18	52	103
68	18.5	20.5	54.5	107
68	20.5	20.5	54.5	109
68	22.5	20.5	54.5	111
68	22.5	23	57	113.5
68	23.5	23.5	57.5	115
68	23	25	59	116
68	25	25	59	118
68	25	26	60	119
68	26	28	62	122
68	26	29.5	63.5	123.5
68	28.5	30.5	64.5	127
73	16	18	54.5	107
73	20	18	54.5	111
73	20	20.5	57	113.5
73	21	21	57.5	115
73	20.5	22.5	59	116
73	22.5	22.5	59	118
73	23.5	25.5	62	122
73	26	28	64.5	127

### BB axle chart

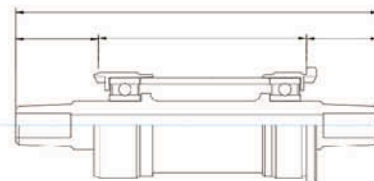



## PT-1860K Light Bearings

IS42/28.6 | IS52/40

- // Integrated, 1. 1/8" Upper / 1.5" Bottom for tapered OD headtube  $\phi 28.6 \times 41.8 \times 51.8 \times 39.8$  (conical cone OD size  $\phi 48\text{mm}$ )
- // Height 9.4+0.8=10.2mm, top cover H:8mm
- // Weight 66g
- // Bearings Sealed AC Bearings (Alloy cone) 41.8x45°x8.4 (R446 A) Upper 51.8x45°x8(R447A) Lower
- // Material Top cover:AL6061 w/AL7075 crown race
- // Finish Anodized



## PT-1860A

IS42/28.6 | IS52/40

- // Integrated, 1. 1/8" Upper / 1.5" Bottom for tapered OD headtube  $\phi 28.6 \times 41.8 \times 51.8 \times 39.8$  (conical cone OD size  $\phi 48\text{mm}$ )
- // Height 9+1=10mm, top cover:8mm
- // Weight 74g
- // Bearings Sealed AC Bearings 41.8x45°x8(R418) Upper 51.8x45°x8(R425) Lower
- // Material Top cover:AL6061 w/AL7075 crown race
- // Finish Anodized
- // PT-1860AS crown race  $\phi 30(1\ 1/8")$



## PT-1860M

IS42/28.6 | IS52/40

- // Integrated, 1. 1/8" Upper / 1.5" Bottom for tapered headtube  $\phi 28.6 \times 41.8 \times 51.8 \times 39.8$
- // Height 20+1=21mm
- // Weight 96g
- // Bearings Sealed AC Bearings
- // Material Top cover:AL6061 w/AL7075 crown race
- // Finish Anodized
- // Top Cone & clamp W/Locking function on headsets  
No use starnut or expander on stem



## F-13

ZS44/28.6 | ZS56/40

- // 1.1/8" Upper / 1.5" Bottom
- //  $\phi 28.6 \times ID44 \times ID56 \times 39.8$
- // Height 9.6+2.8=12.4mm
- // Weight 100g
- // Bearings Sealed AC Bearings (41x45°)(52x45°)
- // Material AL6061T6 w/7075 crown race
- // Finish Anodized
- // Headtube OD 50mm ID44mm/ OD 62mm ID56mm



## F-13AB

ZS44/28.6 | ZS56/40

- // 1.1/8" Upper / 1.5" Bottom for tapered headtube  $\phi 28.6 \times ID44 \times ID56 \times 39.8$
- // Height 24.7+2.8=27.5mm
- // Weight 141g
- // Bearings Sealed AC Bearings
- // Material AL6061 w/AL7075 crown race
- // Finished Anodized
- // Rotation angle 130°
- // Alloy headset blocking design top cover



## F-13ABT

ZS44/28.6-26tpi | ZS56/40

- // 1.1/8" Upper / 1.5" Bottom for tapered headtube  $\phi 25.4 \times ID44 \times ID56 \times 39.8$
- (Threaded headset (1.1/8"/1.5")x26T)
- // Height 37+2.8=39.8mm
- // Weight 151g
- // Bearings Sealed AC Bearings
- // Material AL6061 w/AL7075 crown race
- // Finished Anodized
- // Rotation angle 130°
- // Alloy headset blocking design top cover



## F-1805TL

ZS44/28.6-26tpi | ZS44/30

- // 1.1/8"x26T (Internal threaded)
- //  $\phi 25.4 \times 44 \times 30$
- // Height 22+2.8=24.8mm
- // Weight 157g
- // Bearings Semi- Cartridge Bearings
- // Material Steel w/6061-T6 Top cover
- // Finish Anodized/ED BK



**Super Light Expander**

- How to use:**
1. Put expander into front fork, and tighten it with allen key.
  2. Tighten top cap on stem.

## PT-1708 SERIES

1. Available for ID 22~25 range
2. Light weight, full set made by Alloy
3. 3 piece design for better tighten force
4. Length option : L:50mm, L:65mm, L:90mm
5. Appearance by cross lines, or better tighten force
6. 3 separate point design for upper compression and lower compression, the compression force will be more evenly

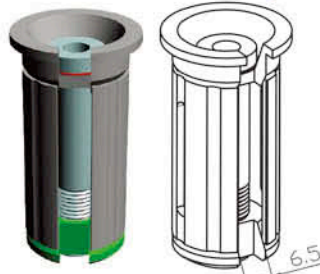

## PT-1709ELD

- // Alloy expander L:50mm
- // Full set made by alloy
- // OD  $\phi 23\text{mm}$  for 1.1/8" sterner/ ID23-24mm.(compatible)
- // w/6.5mm slotted gape for DI2 wire.

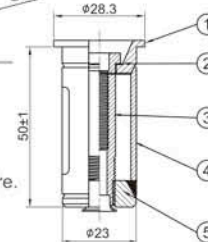

## PT-1710B

- // Cap 1.1/8" flat cap with rubber top plug, double star-nut
- // Steerer 1.1/8"
- // Weight 27g
- // Finish Anodized



LITE

## F-1808G

ZS44/28.6 | ZS44/30

- // 1.1/8" Internal Headset
- //  $\phi 28.6 \times 44 \times 30$
- // Height 7.5+3=10.5mm
- // Weight 77g
- // Bearings Sealed AC bearings 41 x 45° x H6.5 (R408)
- // Material AL-6061 w/steel crown race
- // Finish Anodized



## PT-1710SCF

- // Cap 1.1/8" carbon looking design top cap
- // Weight 23.5g



**PT-6635T**

- // Press fit B.B 386/PF 30
- // L/R cup OD ø46mm
- // Double sealed cartridge bearings
- CNC machined alloy cups
- // Anodized available
- // Weight:115g
- // Option: 6635TCB ceramic bearings
- BB 386 frame ø46 x 86.5mm
- PF30 frame (ø46 x 68/73mm)
- Between L/R cups w/threaded locking on design**



**PT-6635P**

- (BB386 )
- // Press fit B.B 386
  - // L/R cup OD ø46mm
  - // Double sealed cartridge bearings
  - // BB386 frame ( ø46 x 86.5mm)
  - PF30 frame (ø46 x 68/73mm)
  - // Alloy shell & PVC cups



**PT-6635SL**

- (BB386 adapter for shimano)
- // CNC machined alloy cups
  - // L/R cup OD46mm
  - // Adapts for BB386 frame (ø46 x 86.5mm) to fit Shimano cranksets
  - // Weight:116g
  - // Compatible with Shimano groups
  - // Anodized available



**PT-6635AT**

- (BB386 adapter for shimano)
- // CNC machined alloy L/R cups
  - // L/R cups OD 46mm
  - // Adapts for BB386 frame (ø46\*86.5mm width)
  - // To fit shimano cranksets
  - // Weight:133g
  - // Anodized available
  - // \*Center shell W/Threaded lock on design)



**PT-6637H**

- (PF30 adapter for SHIMANO)
- // PF30 B.B for transform into BB24
  - L/R cup OD46mm
  - // Press fit for MTB/ Road
  - // Double sealed cartridge bearings
  - ( OD 37mm x ID24 x H:8mm )
  - // Compatible with Shimano groups
  - // Weight/ 140g



**PT-6639**

- // PF30 B.B for transform into BB24
- L/R cup OD46mm
- // Press fit for MTB/ Road
- // Double sealed cartridge bearings
- // Compatible with Shimano groups
- // Weight 165g



**PT-6632F**

- // "B.B 30 transform into BB24 L/R cup, for Road/MTB
- // w/seals cartridge bearings
- // Compatible with Shimano groups
- // BB30 adaptor for Shimano
- // Center shell w/ Threaded lock on design



**PT-6632D**

- (BB30 adapter for SHIMANO)
- // CNC machined alloy cups
  - // Alloy shell
  - // sealed cartridge bearings L/R cup OD42mm
  - // BB30 for transform into BB24,
  - // Press fit for MTB / Road
  - // Weight:126g w/alloy shell
  - // Compatible with shimano groups
  - // Anodized available
  - // Option: PT-6632DCB Double ceramic bearings



**PT-6632A**

- BB30A24
- // BB30A BB for 24mm spindle L/R 42mm OD & shell width 73mm
  - // Double Sealed cartridge bearings
  - // Compatible with shimano groups
  - // L/R cups w/threaded lock on design
  - // Weight:133g
  - // Option:6632AM compatible with SRAM groups.



**PT-6639A**

- For Shimano / PF30A24
- // PF30A BB for 24mm spindle L/R cup 46mm/ shell width 73mm
  - // Double Sealed cartridge bearings
  - // Compatible with Shimano groups
  - // L/R cups w/threaded lock on design
  - // Weight:149 g
  - // Option: 6639AM compatible with SRAM groups.



**PT-6624AT**

- BB86/92 for 24mm cranksets
- // CNC machined alloy cups L/R
  - // L/R cups OD41mm
  - // Double Sealed cartridge bearing
  - // BB86/92 Press fit for Road/MTB(SHIMANO)
  - // Weight:113g
  - // Anodized available
  - // Center shell w/ Threaded lock on design



**PT-6624**

- (BB86/BB92 for 24mm cranksets )
- // Forged alloy and CNC machined cups
  - // Double sealed cartridge bearings
  - // Plastic shell
  - // BB86/92 Press fit for Road / MTB(SHIMANO)
  - // Weight/ 82g
  - // Anodized available
  - // Option/ PT-6624CB ceramic bearings



**PT-6623**

- BB86/BB92 for 22/24mm cranksets
- // Forged alloy and CNC machined cups
  - // Double sealed cartridge bearings
  - // Plastic shell
  - // BB86/92 Press fit for SRAM Road / MTB
  - // Anodized available
  - // Option:PT-6623CB ceramic bearings



**PT-6633ACB**

- // Forged alloy and CNC machined cups
- // Carbon shell, Double ceramic bearings
- // BC 1.37"x24T, 68 and 73mm width
- // Weight 110g w/Carbon shell
- // Compatible with SHIMANO groups (MTB/ Road)
- // Anodized available



**PT-6630D**

- // BC 1.37"x24T-68 and 73mm width
- // Plastic shell
- // Double Sealed cartridge Bearings
- // Anodized
- // Weight 111g
- // Compatible with SRAM groups
- // For MTB / Road
- // Option PT-6630DCB ceramic bearings



**PT-6629D**

- // BC 1.37"x24T-68 and 73mm width
- // Plastic shell
- // Double Sealed cartridge Bearings
- // Anodized
- // Weight:99g
- // Compatible with SHIMANO groups(Road /MTB)
- // Option/ PT-6629DCB ceramic bearings





CH-47

Sets 6pcs-Waterproof  
Cup Steel  
Thread 1.37"x24T (BSA)  
Rotator Ball Retainer  
Weight 338g



CH-46

Sets 7pcs-Waterproof  
Cup Steel  
Sleeve Nylon Plastic  
Thread 1.37"x24T (BSA)  
Rotator Ball Retainer-Cartridge  
Weight 360g



CH-39-1A

**CARTRIDGE TYPE FOR BMX**  
Axle SCM 435,8T Spline,150mm  
Cup Steel  
Thread 1.37"x24T (BSA)  
Weight 456g



CH-50

**CARTRIDGE TYPE**  
Axle Steel,ISO Square Cotterless Axle  
Cup Nylon Fiber  
Thread 1.37"x24T (BSA)  
Rotator Sealed Bearing 2pcs  
Weight 280g



CH-49

**CARTRIDGE TYPE**  
Axle Steel,ISO Square Cotterless Axle  
Cup Nylon Fiber  
Thread 1.37"x24T (BSA)  
Rotator Sealed Bearing 2pcs  
Weight 288g



CH-51

**CARTRIDGE TYPE**  
Axle Steel,ISO Square Cotterless Axle  
Cup Nylon Fiber(Left),Steel(Right)  
Thread 1.37"x24T (BSA)  
Rotator Sealed Bearing 2pcs  
Weight 325g



CH-52

**CARTRIDGE TYPE**  
Axle Steel,ISO Square Cotterless Axle  
Cup Steel  
Thread 1.37"x24T (BSA)  
Rotator Sealed Bearing 2pcs  
Weight 348g



CH-55

**CARTRIDGE TYPE**  
Axle Steel,ISO Square Cotterless Axle,  
Hollow Axle  
Cup,Sleeve Alloy  
Thread 1.37"x24T (BSA)  
Rotator Sealed Bearing 2pcs  
Weight 252g



CH-40

**CARTRIDGE TYPE FOR BMX AND EX**  
Axle SCM 415,10T Spline,150mm  
Cup Forged 6061-T6 Aluminum  
Thread M47xP1.0  
Weight 655g



CH-85

**SPLINE B.B. SET,HOLLOW SPINDLE**  
Axle SCM435(Thread M15xP1.0)  
Cup,Sleeve Alloy  
Thread 1.37"x24T (BSA)  
Rotator Sealed Bearing 2pcs  
Weight 245g



CH-95

**SPLINE B.B. SET,HOLLOW SPINDLE**  
Axle SCM435(Thread M15xP1.0)  
Cup Alloy Sleeve Nylon Plastic  
Thread 1.37"x24T (BSA)  
Rotator Sealed Bearing 2pcs  
Weight 165g



CH-41

**CARTRIDGE TYPE FOR BMX**  
Axle BMX-7(SCM 415,10T Spline,150mm)  
Cup Forged 6061-T6 Aluminum  
Thread 1.37"x24T (BSA)  
Weight 456g



MB

M12

M15



# neco

## Professional Bike Parts Manufacturers

NECO TECHNOLOGY INDUSTRY CO., LTD

www.necoparts.com



### B910

**WEIGHT** B910/312.6g, B910P/292g, B910PP/266g  
**COMPONENTS** 10B21 Spindle, Steel Cups, 2pcs Sealed Bearing Mechanism, Steel Body  
**LOCKING RING COLOR** ED  
**APPLICATIONS** MTB & ATB, Road  
**SPINDLE LENGTH** 110.5mm, 113.5mm, 115mm, 116mm, 118mm, 122.5mm & 127.5mm for 68mm, 70mm & 73mm Widths  
**OPTIONAL:** B911 For Fat Bikes

B910 - B910P - B910E - B910PP: BC 1.37"x24T, R/L  
 B910B: Italian 36mm x 24T, R/R  
 B910P: Steel Right Cup & Nylon Left Cup  
 B910E: E-type Steel Cup  
 B910PP: Nylon Cups



### B920HAL

**WEIGHT** B920A/276g, B920AL/277g, B920AAL/250g, B920HAL/255g  
**COMPONENTS** Cr-Mo Stain Hollow Spindle, 2pcs Sealed Bearing Mechanism, Alloy Cups & Steel Body  
**APPLICATIONS** Trekking & Comfort  
**SPINDLE LENGTH** 110.5mm, 113.5mm, 115mm, 116mm, 118mm, 122.5mm & 127.5mm for 68mm, 70mm & 73mm Widths

B920AL - B920HAL: BC 1.37"x24T, R/L  
 B920BAL - B920HBAL: Italian 36mm x 24T, R/R  
 Alloy Cups, Steel Body (B920AL)  
 Steel Cups, Alloy Body (B920A)  
 Alloy Cups, Alloy Body (B920AAL)



### B940

**WEIGHT** B940/228g  
**COMPONENTS** Cr-Mo Stain Hollow Spindle, 2pcs Sealed Bearing Mechanism, Alloy Cups & Carbon Body  
**APPLICATIONS** MTB & ATB, Road  
**SPINDLE LENGTH** 110.5mm, 113.5mm, 115mm, 116mm, 118mm, 122.5mm & 127.5mm for 68mm, 70mm & 73mm Widths

940: BSA 1.37" x 24T, R/L



### B952

**WEIGHT** 280g  
**COMPONENTS** ISIS Spline Hollow Axle(SCM440), Cold Forged & CNC Machined Steel Cups, Steel Body, Sealed Bearing 2pcs  
**ISIS SPINDLE LENGTH** 108mm, 113mm, & 118mm, 128mm for 68mm & 73mm Widths (128mm w/ M12 Bolt)

BSA 1.37" x 24T, R/L



### B953

**WEIGHT**  
**COMPONENTS** ISIS Spline Hollow Axle(SCM440) Cold Forged & CNC Machined Alloy Cups w/ Dust Seal, Alloy Body, Sealed Bearing 3pcs  
**ISIS SPINDLE LENGTH** 108mm, 113mm, & 118mm, 128mm for 68mm & 73mm Widths (128mm w/ M12 Bolt)

BSA 1.37" x 24T, R/L



### B957

**WEIGHT** 557g  
**COMPONENTS** ISIS Spline Hollow Axle(SCM440) Cold Forged & CNC Machined with Alloy Cups w/Dust Seal  
**ISIS SPINDLE LENGTH** Alloy Body, Sealed Bearing 2pcs 113mm, & 118mm, for 68mm & 73mm Widths

THREADS

M48xP1.5, R/L



### B401

**MATERIAL** Forged Alloy and CNC Machined External Cups, Plastic Center Sleeve  
**SIZE** English Threading (BC 1.37"x24T, R/L) for 68mm, 73mm Width Oversized Sealed Bearing Ø 24mm Spindle OD  
**FINISH** Anodized Cups  
**WEIGHT** 106g  
**OPTIONAL** With Ceramic Bearing

FOR MTB

### B501

**MATERIAL** Forged Alloy and CNC Machined External Cups, Plastic Center Sleeve  
**SIZE** English Threading (BC 1.37"x24T, R/L) for 68mm & 73mm Width Oversized Sealed Bearing Spindle OD Left: 22mm Spindle OD Right: 24mm Anodized Cups  
**FINISH**  
**WEIGHT** 116g

FOR ROAD

### BB86 / BB90 / BB92

**MATERIAL** Forged Alloy and CNC Machined External Cups, Plastic Center Sleeve  
**SIZE** Ø 24mm Spindle OD Press Fit Cups Ø41mm Available For:  
 86 mm Frame B.B Shell  
**FINISH** Anodized Color Cups  
**WEIGHT** 95g

PRESS FIT TYPE

| Taiwan: neco@necoparts.com • Tel: +886-4-23323966 | Nanjing: neco-zj@vip.163.com • Tel: +86-511-87455666/777/888  
 | Shunde: sdneco@vip.126.com • Tel: +86-757-22626599 | Tianjin: tjneco@163.com • Tel: +86-22-59591629

# 12o'clock



**12 o'clock Ind.** <http://www.12oclock-bikes.com/>

No.1, Heping Ln., Xiushui Township, Changhua County 504, Taiwan

TEL: +886-4-761-9095

E-mail: johnny30712@12oclock-bikes.com



**▲ SPC-210**  
Carbon seat post in 27.2mm & 31.6mm

**▲ SPC-212**  
zero degree, in 27.2, 30.9 & 31.6mm



**▲ SPC-214**  
Carbon seat post in 27.2mm & 31.6mm

**▲ SPC-215**  
Full carbon seat post in 27.2 & 31.6mm in 300, 350 & 400mm



**▲ SPC-109**  
Carbon seat post in 27.2 & 31.6mm in UD

**▲ SPC-114**  
in 31.6 & 27.2, angle easy adjust



**▲ SDC-002**  
Soft carbon finish saddle with air tunnel design



**▲ SDC-006**  
Carbon finish saddle with ti-tube rails



**▲ SDC-016**  
full carbon saddle with saddle rail 7\*9mm



**▲ SDC-017**  
carbon saddle w/carbon rails



**▲ BCN-025-17** **▲ BCN-025-6**  
**▲ BCN-025**  
Shorter clamp for Di2 junction in 6 & 17 degree



**▲ BCN-026-17** **▲ BCN-026-6**  
**▲ BCN-026**  
Longer clamp for Di2 junction in 6 & 17 degree



**▲ BCN-Name**  
Card holder / number plate holder



**▲ BCN-Name-A**  
card holder/ number plate holder for aero seat post



**▲ BCN-221-P1**  
Nylon direct mount FD cover



**▲ LT-001**  
Multi-functional bar end light for racing bike



**▲ LT-002**  
Multi-functional bar end light for MTB



**▲ BEC-Di2-SP**  
Di2 battery holder for inside of alloy seat post in 27.2 & 31.6mm



**▲ BEC-Di2-SP-C**  
Di2 battery holder for inside of carbon seat post in 27.2 & 31.6mm



**▲ BCN-028**  
in 25.4, 28.6, 31.8 & 34.9mm, H: 11mm



**▲ BCN-106**  
Cyclecross seat clamp 31.8mm & 34.9mm with build-in cable guide



**▲ BCN-123-15**  
Full carbon clamp in 31.8 & 34.9mm



**▲ BCN-207C**  
Carbon chain catcher 53T&36T



**▲ CTS-008**  
chain guide for MTB 1\*9 or 1\*10



**▲ BCN-212-Di2**  
FD clamp, Di2 convertible



**▲ BCN-221**  
Direct mount FD clamp, 34.9mm



**▲ BCN-221-54DM**  
for Moonlander BB



**▲ BCN-222**  
Direct mount FD clamp for boost type



**▲ BCN-110**  
Chain clamp to prevent the chain falls: in 28.6mm, 31.8mm & 34.9mm



**▲ BCN-111-C**  
Cyclecross frame clamp, wheel with cover, in 28.6mm, 31.8mm & 34.9mm



**SUPER LIGHT**

Ti





CC-AL001



CC-AL002



CC-AL004



CC-AL003-46



CC-AL005



CC-AL006



CC-AL007



CC-AL008



CC-AL009



CC-AL009C



CC-AL010



CC-011



CC-012



CC-013



CC-014



CC-016



CC-015-A



CC-AL003



CC-CHB01



CC-CHB01-1



CC-HN01



CC-018



CC-019



CC-AP020



CC-020



CC-021



CC-022



CC-414E

CC-FTP01



CC-FTP02



CC-AD01



CC-CS38S



CC-PC01



CC-PC03

CC-061AQR / LED



CC-061A / LED



CC-RD13



CC-RD17



CC-RD18



CC-PB01



CC-AD13



CC-109CA  
142.8g  
CARBON FIBER

D:31.6mm L:300mm



CC-109A  
164.5g

P.A.T.  
SUPER LIGHT

D:27.2mm L:410mm



CC-ST01



CC-ST03



CC-ST12



CC-ST13

CC-SLEEVE



CC-FD09



CC-BC18



CC-BC17



CC-FS32T



CC-CA04



CC-CA02



CC-FD01



CC-FD02



CC-FD03



CC-FD06



CC-FD07



CC-FD08



CC-STH1

# ORION

軒馬(結成)企業有限公司 CHUAN MA INC.

#110, ALLEY15, CHANSHOULANE, YONGJING TOWNSHIP, CHANGHUA

COUNTY 51246, TAIWAN Web site: www.jyechen.com.tw

TEL: 886-4-8248308 FAX: 886-4-8248313 E-mail: house@ms16.hinet.net



SP-07A  
Alloy Forged Clamp  
Alloy CNC Anodized  
Diam : 25.4/ 27.2mm/ 28.6mm  
Length : 200-600mm

SP-05A  
Alloy Clamp/Alloy CNC Anodized  
Diam : 25.4/ 27.2mm  
Length : 200- 400mm

SP-02A  
Alloy clamp/ Alloy CNC Anodized  
Diam : 25.4/ 27.2/ 28.6/ 31.6mm  
Length : 200- 400mm

SP-09A  
Alloy Clamp/ Alloy Anodized  
Diam : 27.2/ 28.6/ 30.9/ 31.6mm  
Length : 250-600mm

SP-12A  
Alloy Anodized  
Diam : 25.4/ 27.2/ 28.6/ 31.6mm  
Length : 150- 600mm

SP-02B  
Alloy Clamp/Alloy CNC  
Diam : 25.4/ 27.2/ 28.6/ 31.6mm  
Length : 200- 350mm

SP-02P  
Alloy Clamp/Alloy CNC  
Diam : 25.4/27.2/ 28.6/ 31.6mm  
Length : 200- 350mm

SP-02FD  
Alloy Clamp  
Alloy Anodized  
Diam : 28.6/ 34.9mm  
Length : 400- 580mm

JC-C7  
Steel/cr-mo  
Diam : Ø22.2- Ø31.8mm  
Length : 170-400mm

JC-C7A  
Alloy Silver  
Diam : Ø22.2- Ø31.8mm  
Length : 170-400mm

SP-05G  
Alloy Clamp  
Alloy CNC Anodized  
Diam : 25.4/ 27.2mm  
Length : 200- 400mm

JC-01  
Alloy CNC/ Alloy Silver  
Diam : Ø25.4- Ø31.8mm  
Length : 200-580mm

JC-02  
Alloy CNC silver  
Diam: 25.4/27.2/28.6/31.6mm  
Length : 200-400mm

PTR-01  
Seat Post Riser  
Diam: 25.4/ 27.2/28.6/ 30.9mm  
Length : 300-500mm

CA-02



**CHUHN-E INDUSTRIES CO.,LTD.**  
 No., 87, Lane 249, Sec. 1, Yung Shing Rd., Yung Ging, Chang Hwa, Taiwan.  
 Tel:886-4-8221158 http://www.artbicycle.com  
 Fax:886-4-8221196 E-mail:chuhne@ms26.hinet.net



**Wedge clamp seat post**



**PAT**

**1 BOLT SEAT POST**

**DI2 seatpost battery mount**

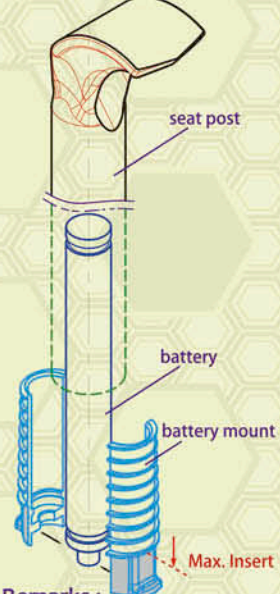

**Remarks:**  
 The insertion & removal of the force from the inner hole of tube should exceed 2.5KGS.

**PAT Patented front-rear 2-bolt seat post**



**for alloy 2014 seatpost**

**DIS-22**  
 Calibre: Ø27.2mm



**DIS-23**  
 Calibre: Ø31.6mm



**HOT-1**, guide you in a carbon fever.



**Screw Thread Clamp**

The clever choice for extending carbon seatpost's life.

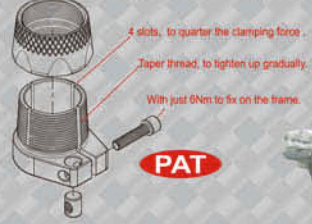

So, it hugs the carbon seatpost firmly, but not hurt the carbon fiber definitely. No worry to bear the one point clamping force and then damage the carbon seatpost as before.  
 Also, it is as a solution when the diameters of frame mast and seatpost do not match accurately.

**PAT**

**for full carbon seatpost**

**DIS-2F**  
 Calibre: Ø27.2mm



**DIS-3F**  
 Calibre: Ø31.6mm



	STC-10	STC-20	STC-30
ØA : seat post dia.	Ø27.2	Ø30.9	Ø31.6
ØB : frame mast dia.	Ø31.6	Ø34.9	Ø34.9



specialized carbon manufacturing







### SORATA PRO

<b>MATERIAL</b>	FORGED / AL6061
<b>OFF SET</b>	3 mm
<b>CRADLE</b>	43 x 42
<b>ANGLE</b>	-5°~+18°
<b>DIAMETER</b>	30.9 / 31.6
<b>LENGTH</b>	365 mm / Travel 100 mm 420 mm / Travel 125 mm 460 mm / Travel 150 mm
<b>WEIGHT</b>	700 g (31.6 x 365)



### SORATA FURY

<b>MATERIAL</b>	FORGED / AL6061
<b>OFF SET</b>	0 mm
<b>CRADLE</b>	43 x 42
<b>ANGLE</b>	-5°~+18°
<b>DIAMETER</b>	30.9 / 31.6
<b>LENGTH</b>	375 mm / Travel 100 mm 430 mm / Travel 125 mm 470 mm / Travel 150 mm
<b>WEIGHT</b>	700 g (31.6 x 375)



### SORATA COMP

<b>MATERIAL</b>	FORGED / AL6061
<b>OFF SET</b>	3 mm
<b>CRADLE</b>	43 x 42
<b>ANGLE</b>	-5°~+18°
<b>DIAMETER</b>	30.9 / 31.6
<b>LENGTH</b>	416 mm / Travel 100mm 445 mm / Travel 125 mm
<b>WEIGHT</b>	741 g (31.6 x 416)



### FLEX

<b>MATERIAL</b>	HIGH MODULUS CARBON FIBER with ARAMID FIBER
<b>OFF SET</b>	20 mm
<b>CRADLE</b>	43 x 42
<b>ANGLE</b>	-5°~+18°
<b>DIAMETER</b>	27.2
<b>LENGTH</b>	350 / 400 mm
<b>WEIGHT</b>	223 g (27.2 x 350)



### TRIDENT LITE

<b>MATERIAL</b>	AL6066 / CARBON
<b>OFF SET</b>	0 mm
<b>CRADLE</b>	43 x 42
<b>ANGLE</b>	-5°~+18°
<b>DIAMETER</b>	30.9 / 31.6
<b>LENGTH</b>	300 / 350 / 400 mm
<b>WEIGHT</b>	266 g (31.6 x 400)



### TRIDENT OF

<b>MATERIAL</b>	AL6066 / AL2014 / CARBON
<b>OFF SET</b>	18 mm
<b>CRADLE</b>	43 x 42
<b>ANGLE</b>	-5°~+18°
<b>DIAMETER</b>	27.2 / 30.9 / 31.6
<b>LENGTH</b>	300 / 350 / 400 mm
<b>WEIGHT</b>	290 g (27.2 x 350, AL6066)



### TRIDENT

<b>MATERIAL</b>	AL6066 / AL2014 / CARBON
<b>OFF SET</b>	0 mm
<b>CRADLE</b>	43 x 42
<b>ANGLE</b>	-5°~+18°
<b>DIAMETER</b>	27.2 / 30.9 / 31.6
<b>LENGTH</b>	300 / 350 / 400 mm
<b>WEIGHT</b>	261 g (27.2 x 350, AL6066)



### CAMBER

<b>MATERIAL</b>	AL6066 / AL2014 / CARBON
<b>OFF SET</b>	24 mm
<b>CRADLE</b>	43 x 38
<b>ANGLE</b>	-5°~+18°
<b>DIAMETER</b>	27.2 / 30.9 / 31.6
<b>LENGTH</b>	300 / 350 / 400 mm
<b>WEIGHT</b>	272 g (27.2 x 350, AL6066)





### ELEGANCE-LT

### HARMONY-LT2

### SOLO

### XOPIC2

<b>MATERIAL</b>	FORGED / AL6061	FORGED / AL6061	FORGED / AL6061	FORGED / AL6061
<b>CRADLE</b>	43 x 30	43 x 32	43 x 36	43 x 35
<b>ANGLE</b>	-5°~+18°	-5°~+18°	-5°~+18°	-5°~+20°
<b>DIAMETER</b>	26.8 / 27.2 / 30.9 / 31.6	27.2 / 30.0 / 30.9 / 31.6	27.2	27.2 / 30.9 / 31.6 / 34.9
<b>LENGTH</b>	305 / 355 mm	300 / 350 mm	305 / 355 mm	305 / 355 / 300 / 350 / 435 / 470 mm
<b>TRAVEL</b>	40 mm	40 mm	40 mm	30 / 40 / 30 / 40 / 50 / 30 / 40 / 50 mm
<b>WEIGHT</b>	496 g (27.2 x 355)	484 g (27.2 x 300)	471 g (27.2 x 305)	513 g (31.6 x 350)



# satori

HLCORP. 信隆車料工業股份有限公司  
 18 Kuang Fu North Road Hsinchu Industrial Park Hu Ko Hsinchu Hsien, Taiwan.  
 TEL : 886-3-5983721 FAX : 886-3-5981861 E-mail : sales@satoribike.com

### ANIMARIS

<b>MATERIAL</b>	FORGED / AL6061
<b>OFF SET</b>	23
<b>CRADLE</b>	43 x 31.5
<b>ANGLE</b>	-5°~+18°
<b>DIAMETER</b>	27.2 / 30.9 / 31.6
<b>LENGTH</b>	350 mm
<b>WEIGHT</b>	680 g





### SP-900ACF/ISO-R

<b>MATERIAL</b>	24T Carbon
<b>DIAMETER</b>	Φ27.2 31.6
<b>OFF SET</b>	20
<b>LENGTH</b>	270 320 370
<b>FINISH</b>	UD Carbon



### SP-327/ISO-R SP-327/ISO-M

►PATENT

<b>MATERIAL</b>	Forged alloy / alloy
<b>DIAMETER</b>	ø27.2 ø30.9 ø31.6
<b>OFF SET</b>	5 25
<b>LENGTH</b>	300 350
<b>FINISH</b>	Sand blasted an bk



### SP-297N/ISO-M

<b>MATERIAL</b>	Forged alloy / alloy
<b>DIAMETER</b>	ø27.2 ø28.6 ø30.4 ø30.9 ø31.6
<b>OFF SET</b>	12
<b>LENGTH</b>	300 350 400
<b>FINISH</b>	Sand blasted an bk or silver



### SP-219N/ISO-M

►PATENT

<b>MATERIAL</b>	Forged alloy / alloy
<b>DIAMETER</b>	ø27.2 ø30.9 ø31.6
<b>OFF SET</b>	16
<b>LENGTH</b>	300 350 400
<b>FINISH</b>	Sand blasted an bk or silver



### SP-406/ISO-M

►PATENT

<b>MATERIAL</b>	Forged alloy / alloy
<b>DIAMETER</b>	ø27.2 ø30.9 ø31.6
<b>OFF SET</b>	0
<b>LENGTH</b>	300 350 400
<b>FINISH</b>	Sand blasted an bk or silver



### SP-215/ISO-M

►PATENT

<b>MATERIAL</b>	Forged alloy / alloy
<b>DIAMETER</b>	ø25.4 ø25.6 ø26.8 ø27.2 ø28.6 ø30.4 ø30.9 ø31.6
<b>OFF SET</b>	22
<b>LENGTH</b>	300 350 400
<b>FINISH</b>	Sand blasted an bk or silver

# SEAT POST SERIES •



Taiwan Bicycle Source 2018-2019

深圳信隆健康产业股份有限公司

中国广东省深圳市宝安区松岗街道办碧头社区第三工业区

邮编：518105

E: sales@hlcorp.com

www.hlcorp.com



▶PATENT

**SP-C255/ISO-M**

<b>MATERIAL</b>	Die-casting alloy/alloy
<b>DIAMETER</b>	ø27.2 ø30.9 ø31.6
<b>OFF SET</b>	15
<b>LENGTH</b>	300 350 400
<b>FINISH</b>	Black/matt black



▶PATENT

**SP-C261/ISO-M**

<b>MATERIAL</b>	Die-casting alloy/alloy
<b>DIAMETER</b>	ø27.2 ø30.9 ø31.6
<b>OFF SET</b>	0
<b>LENGTH</b>	300 350 400
<b>FINISH</b>	Black/matt black



▶PATENT

**SP-C212/ISO-M**

<b>MATERIAL</b>	Die-casting alloy/alloy
<b>DIAMETER</b>	ø25.4 ø25.6 ø27.2 ø28.6 ø30.4 ø30.9 ø31.6
<b>OFF SET</b>	12.9
<b>LENGTH</b>	300 350 400
<b>FINISH</b>	BED / lathe an bk



▶PATENT

**SP-C208/ISO-M**

<b>MATERIAL</b>	Steel / die-casting alloy/alloy
<b>DIAMETER</b>	ø25.4 ø25.6 ø26 ø26.6 ø26.8 ø27 ø27.2 ø28.6 ø29.2 ø29.8 ø30.0 ø30.2 ø30.4 ø30.6 ø30.9 ø31.2 ø31.6 ø31.8
<b>OFF SET</b>	17.5
<b>LENGTH</b>	200 230 250 300 350 400
<b>FINISH</b>	BED / lathe an bk

**SP-C207/ISO-M**

<b>MATERIAL</b>	Die-casting alloy/alloy
<b>DIAMETER</b>	ø25.4 ø25.6 ø26 ø26.6 ø26.8 ø27 ø27.2 ø28.6 ø29.2 ø29.8 ø30.0 ø30.2 ø30.4 ø30.6 ø30.9 ø31.2 ø31.6 ø31.8
<b>OFF SET</b>	16
<b>LENGTH</b>	200 230 250 300 350 400
<b>FINISH</b>	Barreled silver or BED/ lathe an silver

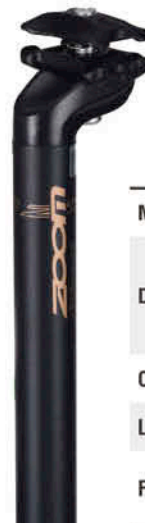
**SP-216/ISO-M**

<b>MATERIAL</b>	Forged alloy / alloy
<b>DIAMETER</b>	ø25.4 ø25.6 ø27.2 ø28.6 ø30.4 ø30.9 ø31.6
<b>OFF SET</b>	22
<b>LENGTH</b>	300 350 400
<b>FINISH</b>	Sand blasted an bk or silver

**SEAT POST SERIES •**



►PATENT	<b>SPS-C372/ISO-C</b>
<b>MATERIAL</b>	Die-casting alloy/alloy
<b>DIAMETER</b>	ø25.4 ø25.6 ø26.6 ø26.8 ø27.2 ø28.6 ø30.9 ø31.6
<b>OFF SET</b>	17
<b>LENGTH</b>	300 350
<b>FINISH</b>	Barreled silver or BED/lathe an silver



►PATENT	<b>SPS-327/ISO-C</b>
<b>MATERIAL</b>	Forged alloy / alloy
<b>DIAMETER</b>	ø30.9 ø31.6
<b>OFF SET</b>	5 25
<b>LENGTH</b>	300 350
<b>FINISH</b>	Barreled an bk / lathe an silver Barreled an silver / lathe an bk



►PATENT	<b>SPS-405/ISO-C</b>
<b>MATERIAL</b>	Forged alloy / alloy
<b>DIAMETER</b>	ø27.2 ø31.6
<b>OFF SET</b>	14
<b>LENGTH</b>	300 350
<b>FINISH</b>	Barreled an bk / lathe an silver Barreled an silver / lathe an bk



►PATENT	<b>SPS-79/ISO-C</b>
<b>MATERIAL</b>	Steel
<b>DIAMETER</b>	ø25.4 ø25.6 ø27.2 ø28.6
<b>---</b>	<b>---</b>
<b>LENGTH</b>	260 300 350
<b>FINISH</b>	CP BED D.SF



	<b>SP-181/ISO-M</b> <b>SP-AL-181/ISO-M</b>
<b>MATERIAL</b>	Forged alloy / steel Forged alloy / alloy
<b>DIAMETER</b>	(ST) / ø25.4 ø27.2 ø28.6 (AL) / ø25.4 ø25.6 ø26.8 ø27.2 ø28.6 ø30.4 ø30.9 ø31.6
<b>OFF SET</b>	0
<b>LENGTH</b>	200 250 300 350
<b>FINISH</b>	(ST) barreled an bk / BED (AL) barreled an bk / lathe an bk



	<b>SP-102/ISO-M</b>
<b>MATERIAL</b>	Alloy
<b>DIAMETER</b>	ø25.4 ø25.6 ø26.8 ø27.2 ø28.6 ø30.4 ø30.9 ø31.6 ø34
<b>LENGTH</b>	(ø34) / 500 550 580 (ISO-M) / 200 230 250 300 350
<b>FINISH</b>	Lanthe an bk or silver Sand blasted an bk or silver (ø34)

# SEAT POST SERIES •



# SP-3D1

**EM-R/EN-M approved**  
**3D forged one-piece, 6061-T6 shaft**

Diameter: 27.2/30.9/31.6mm  
 Length: 300/350mm  
 Offset: 12mm  
 Weight: 290g(27.2mm)  
 Finished: S.B.Black



# SP-DC1

**EN-M/EN-R approved**  
**Die Cast Clamps, 6061-T6 shaft**

Diameter: 27.2/30.9/31.6mm  
 Length: 27.2/30.9/31.6mm  
 Offset: 15mm  
 Finished: ED Black/Lathing



# SP-619

**EN-M approved**  
**Forged head, 6061-T6 shaft**

Diameter: 27.2/30.9/31.6mm  
 Length: 300/350mm  
 Offset: 15mm  
 Weight: 320g (27.2mmx350L)  
 Finished: S.B.Black



# SP-629

**EN-M approved**  
**Forged head, 2014-T6 shaft**

Diameter: 27.2/30.9/31.6mm  
 Length: 300/350mm  
 Offset: 15mm  
 Weight: 275g(27.2mmx350L)  
 Finished: S.B.Black



# SP-729

**EM-R/EN-M approved**  
**3D forged one-piece, 7050-T6 shaft**

# SP-719

**EM-R/EN-M approved**  
**3D forged one-piece, 6061-T6 shaft**

Diameter: 27.2/30.9/31.6mm  
 Length: 300/350mm  
 Offset: 15mm  
 Weight: 260g(SP-729 in 27.2mm)  
 270g(SP-719 in 27.2mm)  
 Finished: S.B.Black



**Kalloy**

186, DA CHOU RD., SHEN KANG 429, TAICHUNG, TAIWAN.

TEL:+886 4 25250555 FAX:+886 4 25274838 +886 4 25287471 E-mail:info@kalloyuno.com

## WARNING LIGHT SP



**AVAILABLE FOR ALL MJ CYCLE SEATPOSTS.**  
LET US KNOW WHICH SEATPOST AMONG OUR EXTENSIVE  
LINE YOU NEED THE WARNING LIGHT ON.

**USB RECHARGEABLE**

comes with cap cover  
(Not shown).

**3 LIGHTED MODES**

- Steady
- Flashing
- Rapid Flashing

**EXTERNAL BATTERY CONNECTOR**

Located at the base of the  
seatpost. Extend the  
operating time of your light.



### MSP-279 SERIES

**MATERIAL** MSP-279-CAL Carbon fiber tube, alloy head  
MSP-279-6 3-D forged 6061 T6 alloy  
MSP-279-7 3-D forged 7050 T6 alloy

**DIAMETER** 27.2 / 30.9 / 31.6 mm  
**LENGTH** 300 / 350 / 400 mm  
**OFFSET** 0 mm  
**WEIGHT** MSP-279-CAL 245 grams (D: 31.6, L: 350)  
MSP-279-7 247 grams (D: 31.6, L: 350)



### MSP-268 SERIES

**MATERIAL** MSP-268A 3-D forged 6061 T6 alloy  
MSP-268-1 3-D forged 6061 T6 alloy

**DIAMETER** MSP-268-6NC 3-D forged 6061 T6 alloy with CNC-machining

**LENGTH** MSP-268-7NC 3-D forged 7050 T6 alloy with CNC-machining

**OFFSET** 27.2 / 30.9 / 31.6 mm  
300 / 350 / 400 mm  
0 mm

**WEIGHT** MSP-268A / MSP-268-1 268 grams (D: 31.6, L: 350)  
MSP-268-6NC 265 grams (D: 31.6, L: 350)  
MSP-268-7NC 265 grams (D: 31.6, L: 350)



### MSP-253A

**MATERIAL** 3-D forged 6061 T6 alloy

**DIAMETER** 27.2 / 30.9 / 31.6 mm  
**LENGTH** 300 / 350 / 400 mm  
**OFFSET** 20 mm  
**WEIGHT** 295 grams (D: 31.6, L: 350)



### MSP-255A

**MATERIAL** Forged 6061 T6 head with alloy tube

**DIAMETER** 27.2 / 30.9 / 31.6 mm  
**LENGTH** 300 / 350 / 400 mm  
**OFFSET** 0 mm  
**WEIGHT** 268 grams (D: 27.2, L: 350)



### MSP-267

**MATERIAL** 3-D forged 6061 T6 alloy

**DIAMETER** 27.2 / 30.9 / 31.6 mm  
**LENGTH** 300 / 350 / 400 mm  
**OFFSET** 20 mm



# EZ SPRING SYSTEM

PATENTED DESIGN // A SINGLE HEX KEY IS ALL THAT'S NEEDED FOR QUICK AND EASY SEATPOST ADJUSTMENT



## MSP-265 SERIES

**MATERIAL** MSP-265-6 3-D forged 6061 T6 alloy  
MSP-265-7 3-D forged 7075 T73 alloy

**DIAMETER** 27.2 / 30.9 / 31.6 mm  
**LENGTH** 250 / 300 / 350 / 400 mm  
**OFFSET** 0 mm

**WEIGHT** MSP-265-6 260 grams (D: 27.2, L: 350)  
MSP-265-7 230 grams (D: 27.2, L: 350)



## MSP-266 SERIES

**MATERIAL** MSP-266-6 3-D forged 6061 T6 alloy  
MSP-266-7 3-D forged 7050 T6 alloy

**DIAMETER** 27.2 / 30.9 / 31.6 mm  
**LENGTH** 300 / 350 / 400 mm  
**OFFSET** 15 / 20 mm

**WEIGHT** MSP-266-7 240 grams (D: 31.6, L: 350)



## MSP-270-CAF

**MATERIAL** Full carbon fiber  
**DIAMETER** 27.2 / 30.9 / 31.6 mm  
**LENGTH** 300 / 350 mm  
**OFFSET** 15 mm



## SEATPOST CLAMPS

### MQC-93NC

**MATERIAL** Fully CNC-machined 7050 T6 alloy  
**DIAMETER** 28.6 / 29.8 / 31.8 / 34.9 mm  
**HEIGHT** 12 mm  
**WEIGHT** 25 grams (Diameter: 34.9)



### MC-75NC

**MATERIAL** Fully CNC-machined 6061 T6 alloy  
**DIAMETER** 31.8



### MC-93NC

**MATERIAL** Fully CNC-machined 7050 T6 alloy  
**DIAMETER** 28.6 / 29.8 / 31.8 / 34.9 mm  
**HEIGHT** 12 mm  
**WEIGHT** 16 grams (Diameter: 34.9)



### MC-71

**MATERIAL** Forged 6061 T6 alloy  
**DIAMETER** 28.6 / 29.8 / 31.8 / 34.9 mm



### MC-76

**MATERIAL** Forged 6061 T6 alloy  
**DIAMETER** 28.6 / 29.8 / 31.8 / 34.9 mm





# POST MODERNE

安大

## MODERNE TECH CORPORATION

367 Kao Shih Rd., Yangmei,  
Taoyuan 326, Taiwan  
Tel: 886-3-4755171-9  
Fax: 886-3-4755180  
info@postmoderne.com  
www.postmoderne.com



### SF-MT164 / SF-MT164T

UNICON Forks  
Travel: 30 / 40mm  
Suspension: Col spring  
Steerer tube: AL 7075ψ1-1/8"  
Crown / Blade: AL6061  
Brake options: V-brake,  
Roller brake, Disc brake  
Attachment": Fender eyelet  
Weight: 1.58 kg

Features  
Clean design and appearance  
Lightweight  
Adjustable preload  
Fork lower: 3D forged crown + blade  
Thru Axle dropouts (SF-MT164T)



### SF-105N/SF-105NS

UNICON™ Forks  
Travel: 30 / 40mm  
Suspension: Col spring  
Steerer tube: AL 7075ψ1-1/8"  
Crown / Blade: AL6061  
Brake options: Fender eyelet  
Weight: 1.45 kg

Features  
Clean design and appearance  
Lightweight  
Adjustable preload  
Fork lower: 3D forged crown  
+ tube blade  
Curved or straight blade design



### OT-908

Suitable especially to OEM sporty or  
high-end bike  
Looks integrated with the headtube.  
With CNC and anodized aluminum  
and cartridge bearing



### SMICA - Comp

Weight : 135g (25.4x110mm)  
Rise : 8, 17, 35 Degree  
Extension : 90, 100, 110, 120, 130mm  
Steer Clamp : 28.6mm  
Bar Clamp : 25.4, 26.0, 31.8mm  
Body Material : 6061-T6 3D Forged  
Clamp Material : 6061-T6 Cold Forged  
Finish : Bead Blasted Black Anodized/ White Painting



### OT-907

Suitable to OEM & aftermarket city bike  
Designed especially for those steerer  
tubes which are shorter  
Use caged bearing.



### OT-903 / OT-903A Headset Lock

Steerer tube OT-903 : 25.4 / 28.6mm (for quill stem)  
OT-903A : 28.6mm (for ahead stem)

Hydraulic dropper post  
 Diameter: 30.9 / 31.6mm  
 Travel: 100 / 125 / 150 / 170mm  
 Length: 340 / 390 / 440 / 480mm  
 Remote lever options: Left-hand & Universal System  
**Features**  
 Infinite adjustment  
 Anti-dust / water design  
 Tube material: Hard-alloy aluminum  
 Easy maintenance: Replaceable cartridge  
 Anti-scratch design: hard anodizing finish  
 Lightweight FRP actuator internal cable routing  
 Lightweight



■ PM-MT171

■ SMICA-PRO OFFSET



Weight: 230g (27.2 x 350mm)  
 Offset: 16mm  
 Shaft Material: 7075 3D Forged  
 Clamp Material: 7075 Cold Forged  
 Sizes: 27.2, 30.9, 31.6mm  
 Finish: Bead Blasted Black Anodized / CNC / White Painting

PM-705N / N2  
 N Travel : 27mm (horizontal : 15mm, vertical : 23mm) D-height : 98mm  
 N2 Travel : 36mm (horizontal : 24mm, vertical : 28mm) D-height : 111mm  
 Weight : 580g  
 Spring : coil  
 Adjust : Allen Key Preload  
 Damping : MCU  
 7075 one piece 3D forged  
 Size : 27.2, 30.9, 31.6mm  
 Length : 300mm/350mm/400mm  
 Finish : Bead Blasted Black Anodized

■ PM-MT186



Hydraulic dropper post  
 Diameter: 27.2mm  
 Travel: 60 / 80mm  
 Length: 250 / 290mm  
 Remote lever options: Left-hand & Universal System  
**Features**  
 Infinite adjustment  
 Anti-dust / water design  
 Tube material: Hard-alloy aluminum  
 Easy maintenance: Replaceable cartridge  
 2-bolt head  
 Internal cable routing



Travel: 40mm  
 Weight: 385g (27.2x300mm)  
 D-Height: 88mm Spring: MCU  
 Adjust: Allen Key Preload  
 Damping: MCU  
 Body Material: 6061-T6 Aluminum  
 Shaft Material: 6061-T6 3D Forged  
 Size: 26.8/27.0/27.2mm  
 Length: 300mm  
 Finish: Black Anodized Or Silver  
 Protective custom rubber boot  
 CNC machined shims for all sizes up to 31.8mm

Travel: 40mm  
 Weight: 470g (27.2 x 300mm)  
 D-Height: 85mm  
 Spring: Coil  
 Adjust: Allen Key Preload  
 Damping: Preset  
 Body Material: 6061-T6 Aluminum  
 Shaft Material: 6061-T6 Aluminum OS  
 Clamp: Forged Head + Clamps W/M10 Single Bolt.  
 Size: 26.8/27.0/27.2mm  
 Length: 300mm  
 Finish: Black Anodized Or Silver  
 Options: CNC machined shims for all sizes up to 31.8mm

Travel: 40mm  
 Weight: 500g (27.2 x 300mm)  
 D-Height: 98mm D-Height  
 Spring: Coil  
 Adjust: Allen Key Preload  
 Damping: Preset  
 Body Material: 6061-T6 Aluminum  
 Shaft Material: 6061-T6 Aluminum OS  
 Clamp: Forged Head + Clamps W/M10 Single Bolt.  
 Sizes: 25.4-27.2mm  
 Length: 300mm  
 Finish: Silver  
 Options: CNC machined shims for all sizes up to 31.8mm  
 S-Model - Steel inner 540g (27.2 x 300mm)

Travel: 40mm  
 Weight: 390g  
 Spring: Coil  
 Adjust: Allen key  
 Damping: Preset  
 Body: AL 6061  
 Shaft: AL 6061  
 Size: 25.4-27.2mm

■ BRACER-COMP OFFSET



■ CUSHY-ST



■ GLIDE (PM780E)



■ SOLO



■ PM-705N

## LEV Ci



### TRAVEL OPTIONS

27.2: 340/65mm, 380/65mm, 410/100mm, 460/120mm

30.9, 31.6: 410/65mm, 390/100mm, 390/125mm,  
440/150mm, 490/175mm

DIAMETER OPTIONS 27.2, 30.9, 31.6

WEIGHT RANGE 375-461g

## LEV Integra



### TRAVEL OPTIONS

27.2: 340/65mm, 375/65mm, 410/100mm, 460/120mm

30.9, 31.6, 34.9: 300/80mm, 340/100mm, 390/125mm,  
440/150mm, 490/175mm

DIAMETER OPTIONS 27.2, 30.9, 31.6, 34.9

WEIGHT RANGE 410-598g

## LEV Si



### TRAVEL OPTIONS

27.2: 345/65mm, 380/65mm, 415/100mm, 465/120mm

30.9, 31.6: 295/75mm, 345/100mm, 395/125mm, 445/150mm

DIAMETER OPTIONS 27.2, 30.9, 31.6

WEIGHT RANGE 430-562g

## E30i



### TRAVEL OPTIONS

27.2: 300/65mm, 390/65mm, 390/100mm, 435/120mm

30.9, 31.6: 320/75mm, 375/100mm, 430/125mm, 485/150mm

DIAMETER OPTIONS 27.2, 30.9, 31.6

WEIGHT RANGE 450-640g

## E20i



### TRAVEL OPTIONS

27.2: 300/65mm, 390/65mm, 390/100mm, 435/120mm

30.9, 31.6: 320/75mm, 375/100mm, 430/125mm, 485/150mm

DIAMETER OPTIONS 27.2, 30.9, 31.6

WEIGHT RANGE 508-710g

## E10i



### TRAVEL OPTIONS

27.2: 310/65mm, 400/65mm, 400/100mm, 445/120mm

30.9, 31.6: 330/75mm, 385/100mm, 440/125mm

DIAMETER OPTIONS 27.2, 30.9, 31.6

WEIGHT RANGE 517-644g



WWW.KSSUSPENSION.COM

DOWN TO  
EARTH



S.D. Components Co., Ltd. was founded in 1994 and embarked into cycling industry by participating OEM & ODM projects with some renowned cycling brands.

By 2009, to expand our product range and increase brand awareness, S.D. own brand "TMARS" was established. TMARS is a combination of Taiwan and MARS, symbolizing our determination of being the very vanguard of Taiwan cycling industry. TMARS also stands for: Trustiness, Maintenance, Accuracy, Reciprocation and Satisfaction, which is our company motto.

With over 20 years' experience developing bicycle components; S.D. is committed to offer our best service to meet all clients' satisfaction. Our product range includes dropper posts, seat posts, stems, other parts and accessories. S.D. possesses many exclusive patents. We believe that safety is the first priority. Components we developed are tested in house according to ISO 4210:2014 Safety requirements for bicycles.

S.D. Components Co., Ltd. is specialized in OEM manufacturing and ODM development of bicycle parts. You are most welcomed to contact us should you wish to make an inquiry or become our international distributor of TMARS brand.

## S.D. COMPONENTS CO.,LTD.

Add :No.930, Sec. 1, Fanhua Rd.,  
Fuxing Township, Changhua County  
506,Taiwan

Tel:886-4-779-4745

Fax:886-4-779-2927

E-mail:sd.sd@tmars.com.tw

## SD-475

### Suspension Seat Post

Material:Alloy 6061

Dia:27.2/31.6mm

Length:350mm

Travel:20mm

Parallelogram system



## SD-355

### Ultra Light Adjustable Stem

Material:Alloy 6061-T6

Adjustable Angle:up/down 45°

Steer Clamp:28.6mm

Bar Clamp:31.8mm

Length:100mm

Weight:210g





智達(嘉弘)

**FORGING METAL CO., LTD.**  
**SHYE HORNG ENTERPRISE CO., LTD**

510 彰化縣員林鎮員水路1段567-2號

NO.567-2, SEC. 1, YUANSHUEI RD., YUANLIN TOWNSHIP, CHANGHUA COUNTY 510, TAIWAN

FAX: 886-4-8349616

TEL: 886-4-8320936, 8355686

E-MAIL: shye.horng@msa.hinet.net

http://www.shye-horng.com

**NEW**



**For front derailleur**  
**LF-5513**

Diam: 31.8, 34.9m/m  
Material: AL6061  
Cold Forged



**LF-5245**

Diam: 34.9 m/m Height:20mm  
Material: AL6061 Weight:24g  
Cold Forged



**LF-5254**

Diam: 34.9 m/m  
Material: AL6061  
Cold Forged



**LF-5257**

Diam: 31.8, 34.9 m/m  
Material: AL6061  
Cold Forged



**LF-5247**

Diam: 31.8, 34.9 m/m  
Material: AL6061  
Cold Forged



**LF-5231**

Diam: 28.6, 31.8, 34.9m/m  
Material: AL6061  
Cold Forged



**LF-5253**

Diam: 31.8 m/m  
Material: AL6061  
Cold Forged



**LF-5243**

Diam: 31.8 m/m  
Material: AL6061  
Cold Forged



**LF-5244**

Diam: 31.8 m/m  
Material: AL6061  
Cold Forged



**LF-5215**

Diam: 28.6, 31.8, 34.9m/m  
Material: AL6061, 7005  
Cold Forged



**LF-5216**

Diam: 28.6, 31.8, 34.9m/m  
Material: AL6061, 7005  
Cold Forged



**LF-5217**

Diam: 28.6, 31.8, 34.9mm  
Material: AL6061, 7005  
Cold Forged



**LF-5315**

Diam: 28.6m/m  
Material: AL6061  
Cold Forged



**LF-5210**

Diam: 28.6, 31.8, 34.9m/m  
Material: AL6061  
Cold Forged



**LF-5207**

Diam: 28.6, 31.8, 34.9m/m  
Material: Steel Raw  
Cold Forged



**LF-5213**

Diam: 28.6, 31.8, 34.9, 29.8m/m  
Material: AL6061  
Cold Forged



**LF-5233**

Diam: 28.6, 31.8, 34.9m/m  
Material: AL6061  
Cold Forged



**LF-5236**

Diam: 28.6, 31.8, 34.9m/m  
Material: AL6061  
Cold Forged



**LF-5235**

Diam: 28.6, 31.8, 34.9m/m  
Material: AL6061  
Cold Forged



**LF-5238**

Diam: 28.6, 31.8, 34.9m/m  
Material: AL6061  
Cold Forged



**LF-5255**

Diam: 34.9 m/m  
Material: AL6061  
Cold Forged



**LF-5241**

Diam: 34.9m/m  
Material: AL6061  
Cold Forged



**LF-5242**

Diam: 31.8 m/m  
Material: AL6061  
Cold Forged



**LF-5214**

Diam: 28.6, 31.8, 34.9, 29.8m/m  
Material: AL6061  
Cold Forged



**LF-5219**

Diam: 28.6, 31.8, 34.9m/m  
Material: AL6061  
Cold Forged



**LF-6060D**

Material: Alloy lever, alloy nut, and Cr-Mo skewer



**LF-6060E**

Material: Alloy lever, alloy nut, and Cr-Mo skewer



**LF-6060G**

Cold Forged Lever  
Material: Alloy lever, alloy nut, and Cr-Mo skewer



**LF-6060H**

Material: Alloy lever, alloy nut, and Cr-Mo skewer



**LF-6060I**

Material: Alloy lever, alloy nut, and Cr-Mo skewer



SP-3H01  
air seat post

Material : AL7075  
Travel : 100/115/125/150mm  
OD : 30.9/31.6mm  
Length : 390/420/440/490mm

SP-5H01  
hydraulic dropper seat post

Material : AL7075  
Travel : 100/115/125/150mm  
OD : 30.9/31.6mm  
Length : 390/420/440/490mm  
Available for External  
and Internal System



# HYDRAULIC SEATPOST

SP-3P01  
air seat post

Material : AL7075  
Travel : 100/115/125/150mm  
OD : 30.9/31.6mm  
Length : 390/420/440/490mm

SP-5P01  
hydraulic dropper seat post

Material : AL7075  
Travel : 100/115/125/150mm  
OD : 30.9/31.6mm  
Length : 390/420/440/490mm  
Available for External  
and Internal System

SP-3S01  
air seat post

Material : AL7075  
Travel : 100/115/125mm  
OD : 30.9/31.6mm  
Length : 390/420/440mm

SP-5S01  
hydraulic dropper seat post

Material : AL7075  
Travel : 100/115/125mm  
OD : 30.9/31.6mm  
Length : 390/420/440mm  
Available for External  
and Internal System





## 2018 COLLECTION

### SEAT CLAMP



IN-SC31414



IN-SC1501



IN-SC7168



IN-SC1817



IN-SC1717



IN-SC071A



IN-SC7001



IN-SC716



IN-SC1422



IN-SC1421



IN-SC1502



IN-SC2817

### SEAT POST



IN-SP109A

- material: AL7075T6, full CNC machined.
- diameter: 27.20/30.90/31.60mm.
- length: 350/410mm.
- weight: 31.60mm @183g (with titanium bolt)

### COMPUTER MOUNT



IN-CCM

- compatible with Garmin, CatEye cycling computers and GoPro.
- size: 31.80/25.4/22.0



IN-BCM



IN-GCM



IN-GPA



### STEM



IN-ST101



IN-ST102



IN-ST208



IN-ST103



IN-ST104

### MTB & ROAD BIKE CHAINWHEEL



IN-CW96



IN-CW2IN1

- compatible with BCD 104&94&96.
- size: 32/34/36



IN-CB-02

- with double allen key design.
- size: M8\*6.50L&8.50L



- ultra-lightweight stem with huge weigh savings.
- stylish design with 3D forged alloy 7050 construction.
- perfect combination with strength, stiffness & reliability.
- available in different lengths.

# 座管升降調整器

## Adjusters for bicycle seatposts



### 座管升降調整器

功能：行程客製化，有純油壓，純氣壓 以及 油氣混和 的多樣性  
 適用管徑：27.2, 30.9, 31.6 (mm)  
 座管行程：80, 100, 120, 140 (mm)  
 管 徑：15, 16.5, 18, 20, (mm) / 軸心：6, 8 (mm)  
 材 質：鋁管，鐵管，鋁軸，鐵軸

### Adjusters for Bicycle Seatposts

Functions : customized stroke and function designs; hydraulic, Gas and Oil-Gas mixed  
 Workable : Seatpost of dia. 27.2, 30.9, 31.6 (mm)  
 Tubes spec.: dia. 15, 16.5, 18, 20 (mm)  
 Shaft spec. : dia. 6, 8 (mm)  
 Material :Aluminum, Steel



### 萬得富股份有限公司

71752台南市仁德區勝利路132巷16號  
 TEL:886-6-2707563 FAX:886-6-2707966  
 E:-wdfmail@wdf-gaslift.com

### WAN DER FUL CO., LTD.

NO.16, LN. 132, SHENGLI RD., RENDE DIST.,  
 TAINAN CITY 71752, TAIWAN  
 TEL: 886-6-2707563(Direct) FAX: 886-6-2707966  
 www.wdf-gaslift.com

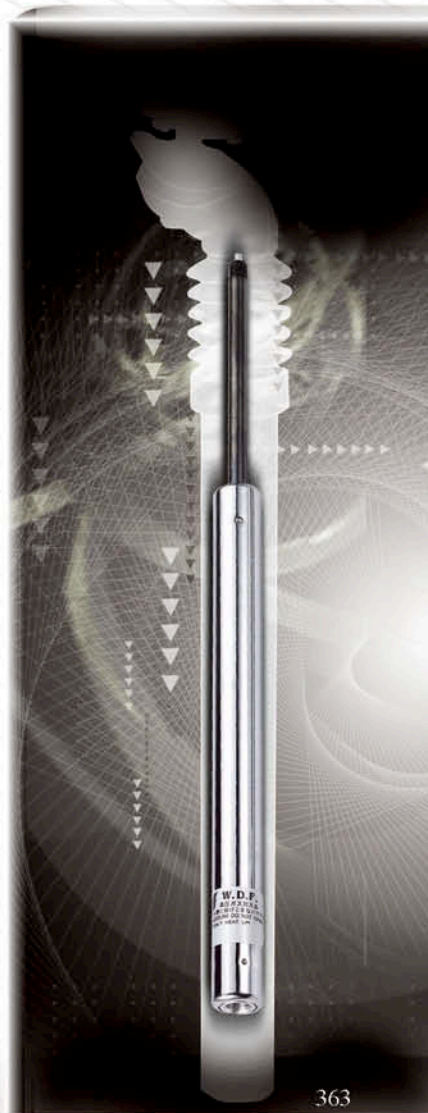





- ISO / 14001
- ISO / TS16949
- ISO 9001:2008/2015

# Never Stop Being Perfect

High Quality / Global Reach / Professional Customized Service

**BEARING**  
**CW**

台慈軸承有限公司 CW Bearing Taiwan Co., Limited

Tel: +886-4-22546936 / Fax: +886-4-22542093

Sales: 張祥慶 Danle +886-978-316061 Daniel.chang@cwbearing.com <http://www.cwbearing.com/>

台中市西屯區市政北七路186號9樓之5 / 9F.-5, No.186, Shizheng N. 7th Rd., Xitun Dist., Taichung City 407, Taiwan



# 高聖峰

高聖峰  
(星嘉)



GAU SHENQ FENG INDUSTRIAL CO., LTD.

17, LN. 370, NANRONG RD., ZHONGHE VIL.,  
DADU DIST., TAICHUNG CITY 432, TAIWAN  
Tel: 886-4-26933407 Fax: 886-4-26931183  
E-mail: sj99.z520@msa.hinet.net

江蘇句容廠—星嘉五金製品有限公司  
Tel:86-511-87422668 Fax:86-511-87422333

**MODEL:SJ-168**  
Size:1/4"x9  
No.04203301

**MODEL:SJ-169**  
Size:5/32"x16  
No.04203302

**MODEL:SJ-170**  
Size:3/16"x7  
No.04203303

**MODEL:SJ-171**  
Size:1/4"x7  
No.04203304

**MODEL:SJ-172**  
Size:7/32"x9  
No.04203305

**MODEL:SJ-173**  
Size:3/16"x15A  
No.04203306



**MODEL:SJ-174**  
Size:5/16"x7  
No.04203307

**MODEL:SJ-175**  
Size:5/16"x9  
No.04203308

**MODEL:SJ-176**  
Size:3/16"x15B  
No.04203309

**MODEL:SJ-179**  
Size:1/4"x11A(B.B.)  
No.042033010

**MODEL:SJ-180**  
Size:5/32"x22,1-1/8"  
**MODEL:SJ-212**  
Size:5/32"x22,1-1/4"  
No.042033011

**MODEL:SJ-184**  
Size:1/4"x10  
No.042033012

**MODEL:SJ-201**  
Size:1/4"x8A  
No.042033013



**MODEL:SJ-203**  
Size:1/4"x9B(3720)  
No.042033014

**MODEL:SJ-204**  
Size:1/4"x11L  
No.042033015

**MODEL:SJ-205**  
Size:1/4"x11B  
No.042033016

**MODEL:SJ-208**  
Size:5/32"x14B  
No.042033017

**MODEL:SJ-213**  
Size:5/32"x22B  
No.042033018

**MODEL:SJ-214**  
Size:5/16"x10  
**MODEL:SJ-215**  
Size:5/16"x12  
No.042033019

**MODEL:SJ-216**  
Size:7/32"x10  
No.042033020



**MODEL:SJ-217**  
Size:5/32"x20C  
No.042033021

**MODEL:SJ-218**  
Size:3/16"x10C  
No.042033022

**MODEL:SJ-220**  
Size:3/16"x18C  
No.042033023

**MODEL:SJ-221**  
Size:3/16"x13C  
No.042033024

**MODEL:SJ-STEEL BALLS**  
Size:1/4" 3/16" 5/32" 1/8" 7/32"  
No.042033025



## ***We meet Just What You Need***

Bike Bearings are the soul for reaching outstanding performances. Combing technologies and high precision, HOPE aims to meet exactly what customers' needs with perfect quality.

**Product**



**HOPE Industrial Corporation**





**HOPMORE**

呈 茂



951 951L 951S



909



911



915

**HOPMORE INDUSTRIAL CO., LTD.**

Add: No.1, Lane 331, Tanhsing Rd., Tanzi Dist.

Taichung City, 427 Taiwan.

Tel: 886-4-25380036

Fax: 886-4-25384471

E-mail: hopmore@ms21.hinet.net

http://www.hopmore.com

http://www.hopmore.com.tw

Executive: C. K. Lin

**HOPMORE:951 951L 951S**

Size: 1-1/8"  
Cassette bearing set

**HOPMORE:909**

Size: 1-1/8"  
Cassette needle bearing set

**HOPMORE:911**

Size: 3/16"x7"  
Front hubs

**HOPMORE:915**

Size: 3/16"x10"  
Rear hubs



918

**HOPMORE:918**

Size: 3/16"x25A  
1-1/2" Head parts



925

**HOPMORE:925**

Size: 5/16"x9"  
BMX B.B. Cup



926

**HOPMORE:926**

Size: 5/16"x12"  
BMX B.B. Cup



930

**HOPMORE:930**

Size: 5/32"x16"  
1" Head parts



933

**HOPMORE:933**

Size: 5/32"x22A  
1" Head parts



934

**HOPMORE:934**

Size: 5/32"x22B  
1-1/8" Head parts



938

**HOPMORE:938**

Size: 5/32"x34A  
1-1/2" Head parts



940

**HOPMORE:940**

Size: 1/4"x7"  
Rear hubs



941

**HOPMORE:941**

Size: 1/4"x9"  
B.B. parts



961

**HOPMORE:961**

Size: 1/8"x25A  
1-1/8" Head parts



962

**HOPMORE:962**

Size: 1/8"x25B  
1-1/8" Head parts



970

**HOPMORE:970**

Size: 7/32"x9"  
Coaster brakes



971

**HOPMORE:971**

Size: 7/32"x7"  
Rear hubs



980

**HOPMORE:980**

Size: 1"x20"  
1" Head parts



981

**HOPMORE:981**

Size: 1-1/8"x22"  
1-1/8" Head parts



983

**HOPMORE:983**

Size: 1-1/8"x26"  
1-1/8" Head parts



988

**HOPMORE:988**

Size: 3/16"x21"  
1-1/8" Head parts



990

**HOPMORE:990**

Size: 32"x20"  
Flat-faced cage ball bearings

# Hsin Tung 新東

NO.24-5,ZHONGQING RD., SHALU DIST., TAICHUNG CITY 433,TAIWAN

TEL:+886-4-26151099

FAX:+886-4-26150401

ht52533344@yahoo.com.tw



**MODEL:HT-436**

Size: 00 x 00

Semi Cartridge Bearing

**MODEL:HT-436**

Size: 00 x 00

Semi Cartridge Bearing

**MODEL:HT-436**

Size: 00 x 00

Semi Cartridge Bearing





HWAN MAW

環茂

**HWAN MAW IND. CO.,LTD**

NO. 33, Lane 40, Peiyang Rd.,Feng Yuan Dist., 420,Taichung, City ,Taiwan.

TEL:886-4-25226545, 25235175

FAX:886-4-25288882

E-mail: hwanmaw@ms64.hinet.net

專營:沖床產品、自行車零件、鋼珠環



HM-1636 HM-1636M

**HM-1630**

Size: 3/16"x 7  
Front hub

**HM-1632**

Size: 3/16"x 15A  
Head parts

**HM-1633**

Size: 3/16"x 15B  
Head parts

**HM-1635**

Size: 3/16"x 20A  
Head parts

**HM-1636**

Size: 3/16"x 20B  
1-1/8"Head parts  
**HM-1636M**  
Size: 3/16"x 20BM  
1-1/8"Head parts  
(Motorcycle)



**HM-1645**

Size: 3/16"x 22B  
1-1/4"Head parts  
(Motorcycle)



**HM-1646**

Size: 3/16"x 18B  
Head parts  
(Motorcycle)



**HM-1647**

Size: 3/16"x 21B  
Head parts  
(Motorcycle)



**HM-1650**

Size: 5/16"x 9  
BMX B.B. parts



**HM-1653**

Size: 5/16"x 12  
BMX B.B. parts



**HM-3251**

Size: 5/32"x 14B  
Head parts



**HM-3253**

Size: 5/32"x 16A  
Head parts



**HM-3254S**

Size: 5/32"x 22A  
1-1/8"Head parts



**HM-3255**

Size: 5/32"x 22B  
1-1/8"Head parts



**HM-3256S**

Size: 5/32"x 20A  
1-1/8"Head parts



**HM-3270**

Size: 7/32"x 9  
Coaster brakes



**HM-3291**

Size: 9/32"x 18A  
Head parts  
(Motorcycle)



**HM-4100**

Size: 1/4"x 7  
Rear hub



**HM-4104**

Size: 1/4"x 9A  
B.B. parts



**HM-4105**

Size: 1/4"x 9L  
B.B. parts



HM-4107

**HM-4107**

Size: 1/4"x 15B  
1-1/8"Head parts

HM-4107M

**HM-4107M**

Size: 1/4"x 15BM  
1-1/8"Head parts  
(Motorcycle)



**HM-4110**

Size: 1/4"x 15A  
B.B. parts



**HM-8100**

Size: 1/8"x 28B  
1-1/8"Head parts



**HM-8103**

Size: 1/8"x 26A  
1-1/8"Head parts



**HM-8104**

Size: 1/8"x 22A  
Head parts



VR4-9Z

VR6-11Z

VR6-9Z

VR4-11Z

HM-TBR 01



**HM-TBR 01**

Size: 5/32"x 12C  
Thrust set

HM-TBR04



**HM-TBR 04**

Size: 3/16"x 10C  
Thrust set



# MAXTON



## MAXTON TRADING COMPANY., LTD.

Add: No.218-3, Da' Angang Rd., Dajia Dist., Taichung City 437, Taiwan

TEL: 886-4-26874565 FAX: 886-4-26801233

<http://www.bearing-maxton.com>

E-Mail: [maxton.bearing@msa.hinet.net](mailto:maxton.bearing@msa.hinet.net)





**TONG YIH HARDWARE CO., LTD.**  
 No.69-3, Anle St., Xiushui Township, Changhua County 504, Taiwan  
 Tel: 886-4-7695858  
 Fax: 886-4-7690728  
 E-mail: t7695858@ms47.hinet.net  
 http://www.wheelgiant.com.tw/tungi



**Model TI-661**  
 Size: 1/4" x 9.  
 Diameter: 23.5mm.  
 For B.B. parts.  
 Packing: 200 pcs/inner box/10 inner box/carton/  
 0.72 cu.ft.  
 Net Weight: 24kg, Gross Weight: 25kg



**Model TI-662**  
 Size: 5/32" x 16.  
 Diameter: 34mm.  
 For head parts.  
 Packing: 200 pcs/inner box/10 inner box/carton/  
 0.76 cu.ft.  
 Net Weight: 13kg, Gross Weight: 14kg



**Model TI-663**  
 Size: 3/16" x 15A.  
 Diameter: 35mm.  
 For head parts.  
 Packing: 200 pcs/inner box/10 inner box/carton/  
 0.80 cu.ft.  
 Net Weight: 19kg, Gross Weight: 20kg



**Model TI-664**  
 Size: 5/16" x 9.  
 Diameter: 38.1mm.  
 For BMX B.B. parts.  
 Packing: 100 pcs/inner box/10 inner box/carton/  
 0.89 cu.ft.  
 Net Weight: 25kg, Gross Weight: 26kg



**Model TI-665**  
 Size: 3/16" x 7.  
 Diameter: 16.0mm.  
 For front hub.  
 Packing: 400 pcs/inner box/10 inner box/carton/  
 0.54 cu.ft.  
 Net Weight: 17kg, Gross Weight: 18kg



**Model TI-666**  
 Size: 1/4" x 7.  
 Diameter: 19mm.  
 For rear hub.  
 Packing: 200 pcs/inner box/10 inner box/carton/  
 0.54 cu.ft.  
 Net Weight: 20kg, Gross Weight: 21kg



**Model TI-667**  
 Size: 1/4" x 9B.  
 Diameter: 28.6mm.  
 For B.B. #3720.  
 Packing: 200 pcs/inner box/10 inner box/carton/  
 0.84 cu.ft.  
 Net Weight: 24.5kg, Gross Weight: 25.5kg



**Model TI-668**  
 Size: 1/4" x 11.  
 Diameter: 35.0mm.  
 For coaster hub.  
 Packing: 100 pcs/inner box/10 inner box/carton/  
 0.72 cu.ft.  
 Net Weight: 14kg, Gross Weight: 15kg



**Model TI-669**  
 Size: 5/16" x 10.  
 Diameter: 38.1mm.  
 For BMX B.B. Parts.  
 Packing: 100 pcs/inner box/10 inner box/carton/  
 0.89 cu.ft.  
 Net Weight: 26kg, Gross Weight: 27kg



**Model TI-681**  
 Size: 5/32" x 22.  
 Diameter: 39.2mm.  
 For 1-1/4" head.  
 Packing: 200 pcs/inner box/10 inner box/carton/  
 0.89 cu.ft.  
 Net Weight: 15kg, Gross Weight: 16kg



**Model TI-678**  
 Size: 5/16" x 12.  
 Diameter: 38.1mm.  
 For BMX B.B. Parts  
 Packing: 100 pcs/inner box/10 inner box/carton/  
 0.89 cu.ft.  
 Net Weight: 27kg, Gross Weight: 28kg



Model	Size	Diamete	Packing	pcs/inner	pcs/carton	Net Weigh	cu.ft.
TI-661	1/4x9	23.5	B.B. PARTS	200	2000	24	0.72
TI-662	5/32x16	34.0	HEAD PARTS	200	2000	13	0.76
TI-663	3/16x15A	35.0	HEAD PARTS	200	2000	19	0.80
TI-664	5/16x9	38.1	BMX B.B.	100	1000	25	0.89
TI-665	3/16x7	16.0	FRONT HUB	400	4000	17	0.59
TI-666	1/4x7	19.0	REAR HUB	200	2000	20	0.59
TI-667	1/4x9B	28.6	B.B. #3720	200	2000	24.5	0.84
TI-668	1/4x11	35.0	COASTER HUB	100	1000	14	0.72
TI-669	5/16x10	38.1	BMX B.B.	100	1000	26	0.89
TI-670	1/4x10	30.5	COASTER HUB	100	1000	13	0.53
TI-671	1/4x8A	20.6	COASTER HUB	200	2000	21	0.59
TI-672	5/32x14B	34.0	HEAD PARTS	200	2000	12.5	0.76
TI-673	1/4x15	38.8	B.B. PARTS	200	2000	21	0.72
TI-674	7/32x9	27.5	COASTER HUB	200	2000	22	0.80
TI-675	5/32x7	14.5	PEDAL	500	5000	20	0.59
TI-676	3/16x11	26.0	B.B. #3717	200	2000	20	0.59
TI-677	3/16x15B	35.0	HEAD PARTS	200	2000	19	0.76
TI-678	5/16x12	38.1	BMX B.B.	100	1000	27	0.89
TI-679	5/32x22A	36.5	1-1/8"	200	2000	12.5	0.76
TI-680	5/32x20	36.5	1-1/8" HEAD	200	2000	14	0.84
TI-681	5/32x22	39.2	1-1/4" HEAD	200	2000	15	0.89
TI-682	1/4x11B.B.	23.5	B.B. PARTS	100	1000	13.5	0.76
TI-683	5/32x22B	35.6	1-1/8" HEAD	200	2000	22	0.84
TI-684	5/16x7	30.5	B.B. PARTS	100	1000	22	0.76
TI-685	7/32x10	25.4	B.B. #3717	100	1000	12	0.36
TI-686	5/32x20A	34.0	HEAD PARTS	200	2000	14.5	0.76
TI-687	3/16x9	20.1	B.B. PARTS	200	2000	16	0.59



**Model TI-801**  
TI-802  
TI-801:  $\Phi$  12.7x $\Phi$  35x9.5.  
TI-802:  $\Phi$  15.9x $\Phi$  35x9.5.  
TI-6000ZZ:  $\Phi$  10x $\Phi$  26x8.

**TI-804**  
TI-803  
TI-804:  $\Phi$  12.7x $\Phi$  28.7x7.3.  
TI-803:  $\Phi$  19.0x $\Phi$  35x9.5.

**TI-6000ZZ**  
TI-6201ZZ  
TI-6000ZZ:  $\Phi$  12 x  $\Phi$  28 x 8.



**Model TI-611/TI-612**  
TI-628/TI-629  
TI-611 M9 x 108mm  
TI-612 M10 x 136,140,145mm  
TI-628 Spindle Sets  
M14 x 165,175,185mm  
TI-629 Spindle Sets  
M14 x 165,175mm

**Model TI-617/TI-618**  
TI-619  
Quick Release.  
TI-617 M6 x 45, 50mm  
TI-618 M6 x 45, 50mm  
TI-619(Alloy) M6 x 45, 50mm



**STEEL BALLS**  
Size: 1/8", 5/32", 3/16", 7/32", 1/4", 9/32", 5/16", 3/8", 7/16", 1/2", 9/16", 5/8".



**Model TI-620/TI-621/TI-622**  
TI-615/TI-616  
Front/Rear Axle set.  
TI-620:(F) 5/16" 3/8"x130, 135,140mm  
TI-621:(R) 3/8"x 165, 170, 175mm  
Size: to order  
Quick Release.  
TI-615 M5 x 126, 128mm  
TI-616 M5 x 160, 165mm



**Model TI-623/TI-624/TI-624-1/**  
TI-625/TI-626/TI-627  
Front/Rear Axle set  
TI-623:(F) 5/16" 3/8"x 130, 135,140mm  
TI-624:(R) 3/8"x 165,175mm  
TI-624-1(R): 3/8"x 175, 180, 185mm  
TI-625/TI-626:(R) 5/16" 3/8"x 130, 135,140mm  
TI-627(R) 3/8"x 165,180,175mm  
Size: to order



**Model TI-627A/TI-627B/TI-627G**  
TI-628A/TI-628B/TI-628C/TI-628D/TI-628E  
(Nut for hub axle set)  
TI-627A Rear hub cone 3/8"  
TI-627B Front hub cone 5/16"  
TI-627C Rear hub cone 3/8"  
TI-627D front hub cone 5/16"  
TI-627E Rear hub cone 3/8"  
TI-627F Front nut and washer 5/16"  
TI-627G Rear lock nut 3/8"  
TI-627H Front lock nut 5/16"  
TI-627I Hub spacer, TI-627J Cotterless nut  
TI-628A rear flange cup 3/8". TI-628B front flange cup 5/16",  
TI-628C rear hub cup 3/8"  
TI-628D rear hub cup 3/8" , TI-628E front hub cup 5/16"

### HEAD SET BEARINGS



### MINITURE BALL BEARINGS



### BOTTOM BRACKET BEARINGS



### NEEDLE BEARINGS



### HUB BEARINGS



### SPECIAL BEARINGS



### FULL BALL BEARINGS



### SEAL PARTS



為社會消費者，提供有保障的商品，是我們的共同責任  
TTN Bearings, your ultra durable partner

導輪  
Jockey Roller

688 2RS  
689 2RS



花鼓 Hub

60 Series · 68 Series  
69 Series



曲柄  
Front Crankset

6804 2RS · 6805 2RS



踏板 Pedal

607ZZ · 686ZZ  
6700ZZ · HK1210



五通中軸  
Bottom Bracket

16x31x10 2RS



Born in Taiwan and growing in the world,  
TTN is always striving for environment  
friendliness and its sustainability.



SINCE 1976 **TAIWAN**  
台灣 永興軸承有限公司

Young Sing Ball Bearing Co., LTD.

地址：新北市新莊區頭前路28號

No.28, Touqian Rd., Xinzhuang Dist., New Taipei City 242, Taiwan

電話：+886-2-89927722

傳真：+886-2-22774971

郵件：sales@ttn-bearing.com.tw ; yungshing@ms31.hinet.net

SINCE 1999 **SHANGHAI**  
上海 上海永興軸承製造有限公司

Shanghai Young Sing Bearing Manufacturing Co.,LTD.

地址：上海市閔行區中春路6805號

No.6805, Zhongchun Rd., Minhang Dist., Shanghai City 201101, China

電話：+86-21-51095565 / 54889060

傳真：+86-21-54888556

郵件：yewu@ttn-bearing.com ; yewu6@ttn-bearing.com

免費服務熱線 4008201969

SINCE 2006 **KUNSHAN**  
昆山 昆山義榮軸承製造有限公司

地址：江蘇省昆山市淀山湖鎮北苑路9號

No.9 Beiyuan Rd,Dianshanlake Town,Kunshan City 215345, Jiangsu

電話：+86-512-57896655 / +86-512-57890066

傳真：+86-512-57891010

郵件：yewu11@ttn-bearing.com ; jishu2@ttn-bearing.com

免費服務熱線 4008201969



正鑄工業股份有限公司 JENG KER INDUSTRIAL CO., LTD

巧佳企業有限公司 CHEAU CHIA ENTERPRISE CO., LTD

台中市后里區舊社路96號 NO.96,JIUSHE RD.,HOULI DIST., TAICHUNG CITY 42148,TAIWAN

TEL: 886-4-25566612

FAX: 886-4-25561358

E-MAIL: sales@steel-ball.com.tw

WEB: www.steel-ball.com.tw

正鑄  
JENG KER

弘得軸承鋼球(嘉興)有限公司 HONGDE BEARING BALLS (JIAXING) CO., LTD

NO.336.XIU XIN RD,XIU ZHOU INDUSTRY AREA JIA XING CITY, ZHE JIANG PROVINCE CHINA

TEL:86-573-82797785

FAX : 86-573-82799317

E-MAIL:dhz405@vip.sina.com



### Products

- ▲ Carbon steel balls AISI 1008-1086
- ▲ Chrome steel balls AISI 52100
- ▲ Stainless steel balls AISI 304,316,420C,440C
- ▲ Iron balls
- ▲ Flying saucer steel balls
- ▲ Bronze balls, etc.,
- ▲ Steel shot

### Grade

- ▲ AFBMA 10#, 16#, 28#, 40#, 60#, 100#, 200#, 300#, 500#, 1000#
- ▲ DIN 5401 CLASS II, III, IV, V.

We had successfully passed ISO9001:2008 quality certification.

We are manufacturer of kinds of steel ball with different size(0.5mm-127mm) and different grade(G10-G1000).

We specialize in this field for 39 years with good quality and pretty competitive price.

Also we have our own manufacturer and professional workers to meet any of your requirements.





**Carbon Steel Ball**

**Chrome Steel Ball**

**Stainless Steel Ball**

**The first and largest  
steel ball manufacturing  
company in Taiwan.**



**YUAN SHENG LOO**

YUAN SHENG LOO MACHINERY CO., LTD

TEL : 886-3-5596105 FAX : 886-3-5593732

ADD : 453, SUN-KEN VILLEGE HSIN-FONG HSIANG HSINCHU TAIWAN

E-MAIL : ysl.ysl4814@msa.hinet.net

<http://www.steelball.com.tw>





**CHIN JIA METAL IND.CO., LTD.**  
 Office: No. 26, Lane 9, Chung Ching N. Rd., Sec. 3, Taipei 103, Taiwan.  
 Tel: 886-2-25911107(Rep.) Fax:886-2-25953035  
 E-mail: chinjia@ms17.hinet.net  
 Factory: No. 45, Chin Hua Rd., Luchu Village, Taoyuan Hsien, Taiwan.  
 Tel: 886-3-3223535(Rep.) Fax: 886-3-3224848



**Model CA-002**  
 Type: Seat pillar pins.  
 Material/Finish: Cr-mo , C-P or BED.  
 Size: Diam: 8mm.  
 Length: 19, 22, 25, 27, 30, 34, 37mm.

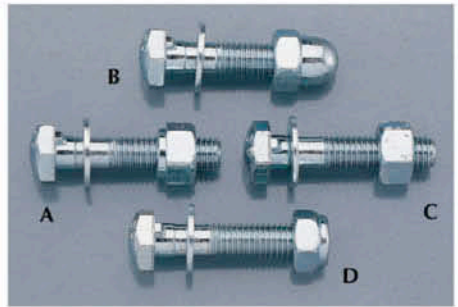

**Model CA-003**  
 Type: Seat pillar pins.  
 Material/Finish: Stainless or carbon steel, steel, C-P, U-C-P, or BED.  
 Size: Diam: 8mm.  
 Length: 33, 35, 38, 40, 43, 45, 48, 50, 55, 60mm.

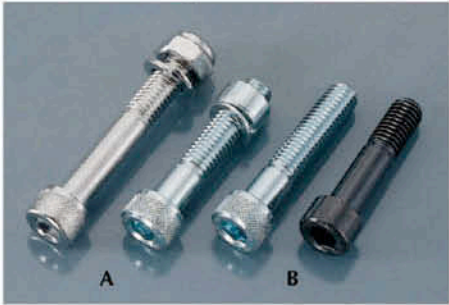

**Model CA-004**  
 Type: Seat pillar pins.  
 Material/Finish: Cr-mo, C-P, U-C-P, or BED.  
 Size: Diam: 8mm.



**Model CA-006**  
 Type: Quick release seat pin with PVC coated lever.  
 Material/Finish: C-P, BED and grey.



**Model CA-007**  
 Type: Quick release seat pin with PVC coated lever.  
 Material/Finish: C-P, BED and grey.

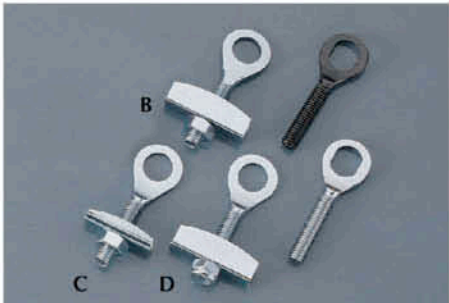

**Model CD-021**  
 Type: Chain adjusters.  
 Material/Finish: U-C-P or BED.  
 Size: M6 x P1.0 thread. 10mm hole & 10 x 11mm hole.  
 Length: 32, 35, 40, 48, 52mm



**Model CD-022**  
 Type: Axle stopper set for GT rear ends.  
 Material/Finish: Steel, C-P or U-C-P.



**Model CE-032A & CE-032B**  
 CE-032A:  
 Type: Hex socket head with 4mm socket width  
 Material/Finish: Cr-mo, stainless/C-P or BED  
 CE-032B:  
 With flat or spring washer



**Model CE-033**  
 Type: Hex socket buttons with 4mm socket width.  
 Material/Finish: Cr-mo or stainless steel.  
 Size: M5 x P0.8 x 10, 12, 15mm.

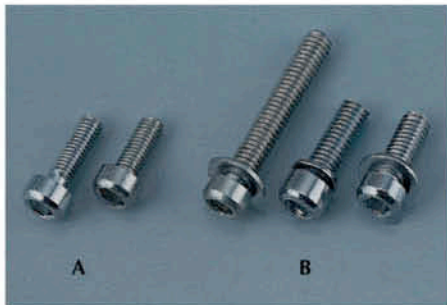

**Model CE-034A & CE-034B**  
 CE-034A:  
 Type: Hex socket head with 5mm socket width  
 Material/Finish: Cr-mo, stainless/C-P or BED  
 CE-034B:  
 With flat washer



**Model CP-041A**  
 Type: Hex socket button head.  
 Size: M6 & M8.

**Model CP-043**

Material: Aluminum alloy 6061  
Size: M8, M10 x P1.25 x 9mm

**Model**

**CR-051:** Hex socket countersunk head cap screw  
**CR-052 A&B :** bottle cage bolt w/washer  
**CE-035** m5 screw w/5mm socket width

**Model CH-061**

Type: Fender screw, pan washer head.  
Material/Finish: U-C-P & stainless.  
Size: M5 x 6, 8, 10, 12, 16, 20mm.

**Model CK-071, CK-071A**

Type: Hex cross head bolt or with washer  
Size: M5, M6, any length.

**Model SGB-001(C)**

Anti-steal quick release seat pin  
size: M8\*35-70  
stainless steel

**Model SGB-003**

Material: steel, crmo, stainless  
Inner & outer expander bolt  
CP blk finished

**Model SGB-008**

Round Head Bolt W/Nylock  
Size: M5, M6  
Finish: UCP, BK

**Model SGB-019**

Quick release stem  
bolt for folding bike  
size to order

**Model SGB-025**

Alloy Quick Release  
Size: M6\*40mm~60mm  
Finish: CP \ UCP \ BK

**Model SGB-032**

Roller bolt set for shocks & frame  
Size: Dia 8, 10, 12mm  
CP finished

**Model SGB-034**

Anti-Theft Bolt  
Suze: M3-M10  
Material: Cr-Mo, Stainless Steel  
CP Finished

**I: Model SGB-003(E)****II: Model SGB-034**

Anti-Theft Bolt Y-Type  
M8 Stainless Steel





**SING GRIL HARDWARE IND. (KUNSHAN) CO., LTD.**  
 No.518 Xinxing South Rd, Kunshan City, Jiangsu, China  
 Tel: 86-512-57613028 Fax: 86-512-57613026  
 E-mail: joe@singgril.com  
 http:www.singgril.com  
 Chin Jia Fastener Manufacturing(Tian jin)Co.Ltd  
 Tel:86-22-59591097-8 Fax:86-22-59591096  
 Aima West Rd,Tianyu Science & Technology Park,Jinghai  
 County,Tianjin,China



**Model SGB-036**  
 Crank Shaft Bolt W/Nylock  
 Size:M8-1.0  
 Finish:CP、NI、BED



**Model SGB-038**  
 Special Part W/Inner Thread  
 Size:9.6\*23.2-M5\*11  
 Finish:BED



**Model SGB-039**  
 A. six-lobe socket hollow bolt  
 B. hex socket hollow bolt



**Model SGB-039**  
 C. hex flange hollow bolt  
 D. hex socket button hollow bolt



**Model SGB-040**  
 Cotterless Axle Bolt For Chainwheel  
 Size: M8-1.0, M10-1.0 - Plastic Cap  
 Finish: CP, BED, AR



**Model SGB-041**  
 Binder bolt For 3-pcs  
 crank arms  
 A. M8x18  
 B. M10x16



**Model SGB-042**  
 Binder Bolt For Alloy Seat-Clamp  
 Size: M5  
 Finish: CP, BED, Stainless Steel



**Model SGB-047**  
 Material: Al6061  
 Bottle Bolt Hex Socket Button  
 Size:M5  
 Finish:Color anode

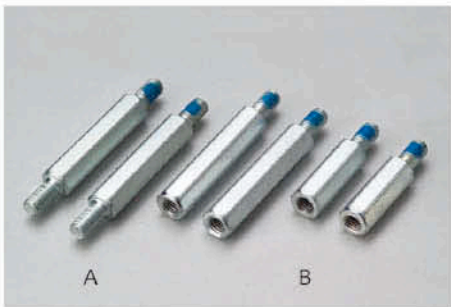

**Model SGB-048**  
 Special Bolt  
 Size:M5  
 Finish:UCP

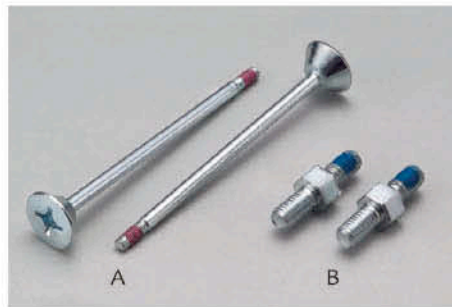

**Model SGB-049**  
 A: Hex Cross Flat Head, Size: M3  
 B: Special Bolt, Size: M5  
 Finish: UCP



**Model SGB-055**  
 A. Cup type with hex socket  
 M6\*27.5/39mm  
 Cr-mo w/cp finished  
 B. U type  
 M6\*20mm ,Cr-mo w/cp finished

# Quality Precision CNC Machined Products

Welcome to inquire and cooperation



CHING SHING PRECISE TECHNOLOGY CO., LTD

No.6, Ln.201, Haiming St., Lukang Township,

Changhua County 505, Taiwan

Tel:+886-4-7750163 / Fax:+886-4-7750167

[www.csptcnc.com](http://www.csptcnc.com)

E-mail: [cnc@csptcnc.com](mailto:cnc@csptcnc.com)



# CHUAN FU SCREW CO., LTD.

No.51, Sec.1, chang Shui Rd., Kun Lun Tsun, Pu Yen Hsiang, Changhua Hsien516, Taiwan  
 Tel: +886-4-8859150 Fax: +886-4-8817439 E-mail: cf439@yahoo.com.tw



### Model CF1

Outer Hex Screw  
 size: 50mm-300mm  
 (Size To Order)

### Model CF2

Inner Hex Screw  
 size: 50mm-300mm  
 (Size To Order)

### Model CF3,CF8

CF3 Umbrella Head Screw.  
 Size: 50mm-300mm(Size To Order)  
 CF8 Hollow Screw Short (long) Head.  
 size: 50mm-300mm(Size To Order)

### Model CF22

Size: 100mm-180mm  
 (Size To Order)



### Model CF10

Inner Hex Bolt.  
 size: 10mm-50mm(Size To Order)

### Model CF30

Inner Hex Bolt.  
 size: 10mm-50mm(Size To Order)

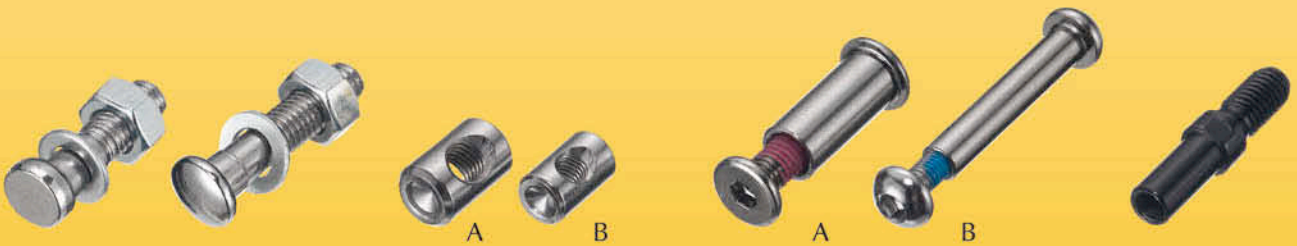

### Model CF11, CF14

CF11 Outer Hex Bolt.  
 CF14 Blossud Head Bolt.

### Model CF31

CF11 Outer Hex Bolt.  
 CF14 Blossud Head Bolt.

### Model CF23

Chinwheel Bolt.

### Model CF32



### Model CF20

size: 10mm-50mm(Size To Order)

### Model CF33



GA-E

ISO 9001

Professional Manufacturer of

# TITANIUM ALLOY BOLT

Anti-corrosive | High Accuracy | High Quality | Lightweight

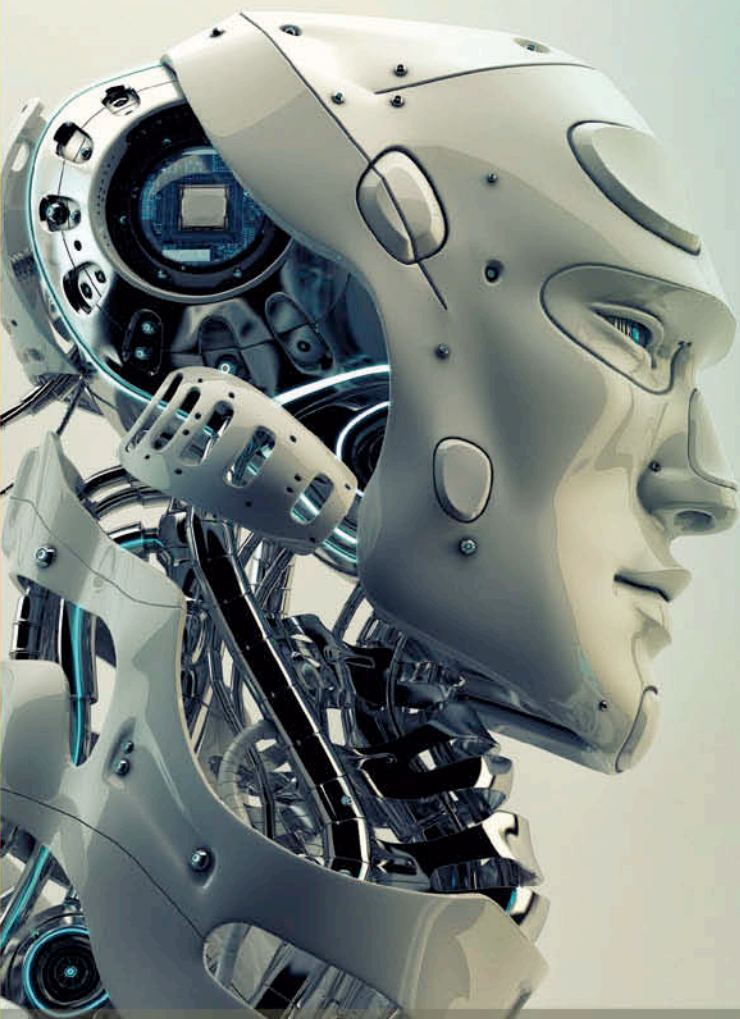

鋼義工業股份有限公司  
GA-E INDUSTRIAL PRECISION CO., LTD

TEL / 886-7-6938503~4  
FAX / 886-7-6930965  
E-mail / gae@gae.com.tw

<http://www.gae.com.tw>



**THROUGH AHLE SYSTEM**

Available for FX/ SR/ SH/ SY/ DT



Model G92

Model G22

Model G87

Model FH

Model FB



Model G60

Model G62



**INTERNAL CAM SYSTEM**



Model F60-00AF/ R60-00AF  
Weight:58g/ 63g

Model F66-00AF/ R66-00AF  
Weight:52g/ 57g

Model F05-00AF/ R05-00AF  
Weight:63g/ 68g

**LIGHT WEIGHT SYSTEM**



Model F52-AVAJ/ R52-AVAJ  
Weight:26g/ 28g

Model F58-AVAM/ R58-AVAM  
Weight:25g/ 27g

Model F78-AVAJ/ R78-AVAJ  
Weight:26g/ 28g

**INTEGRAL SYSTEM**



Model F42-0004/ R42-0004  
Weight:57g/ 61g

Model F46-0004/ R46-0004  
Weight:58g/ 62g

Model F47-00AG/ R47-00AG  
Weight:57g/ 61g

**ANTI-THEFT SYSTEM**



Model F21-AYAK/ R21-AYAK  
Weight:36g/ 39g

Model F11-ABAK/ R11-ABAK  
Weight:49g/ 52g

Model F31-AYAK/ R31-AYAK  
Weight:38g/ 41g



**FULCHEE**

富錡企業股份有限公司  
FUL CHEE ENT CO., LTD.

No. 26, Fong-Ming Rd., Da-Ya Dist.,  
Taichung City, 42872, Taiwan  
Tel: +886-4-25605818 Fax: +886-4-25605806  
E-mail: skewer@fulchee.com  
Http: //www.fulchee.com



**Ti**  
Model F57-ABAP/ R57-ABAP  
Weight:40g/ 43g



**Ti**  
Model F54-ADAV/ R54-ADAV  
Weight:51g/ 57g



Model F04-AJAK/ R04-AJAK  
Weight:32g/ 36g



Model F04-AJ17/ R04-AJ17  
Weight:41g/ 45g



**Ti**  
Model F74-AYAK/ R74-AYAK  
Weight:32g/ 35g



**Ti**  
Model F84-ADAG/ R84-ADAG  
Weight:57g/ 62g



**Ti**  
Model F80-ABAH/ R80-ABAH  
Weight:52g/ 57g



**Ti**  
Model F37-ABAF / R37-ABAF  
Weight:48g/ 53g



**Ti**  
Model F25-AYAF / R25-AYAF  
Weight:34g/ 39g



Model F70-0103 / R70-0103  
Weight:58g/ 64g



Model F73-0102 / R73-0102  
Weight:57g/ 62g



Model F01-0001 / R01-0001  
Weight:95g/ 100g



Model F62-ABAK / R62-ABAK  
Weight:46g/ 51 g



Model F88-AYAF/ R88-AYAF  
Weight:44g/ 49g



Model F69-ABAH/ R69-ABAH  
Weight:50g/ 55g

## FAT BIKE SELECTION

For OLD 135, 190mm Hub  
Length(L): 151.5, 210mm



Model A69-ADBY/ C69-ADBZ  
Type: Hub Q,R  
Material: Axle is S45C  
Axle Diam: A:9mm, C:10mm  
Length(L): 112,148.5  
Weight:80g/ 110g



Model B16-ADBY/ D16-ADBZ  
Type: Hub Q,R  
Material: Axle is AL7075  
Axle Diam: B:9mm, D:10mm  
Length(L): B=112,D=148.5  
Weight:64g/ 79g



Model 232 / 232-1  
Type: Car Roof-Rack Skewer  
Material: Cr-mo  
Axle Diam: 9mm  
Length(L):116 Length (B):141  
Weight:154g/ 152g



Model S02-0218 / S70-AGAT  
Type: Seat Pin Q,R  
Material: Axle is Cr-mo, Axle  
Diam: M6 or M8 / M6  
Length(L):25, 28, 30, 35, 40, / 28, 33  
Length(B):45, 48, 50, 55, 60, / 43, 48  
Weight:94g/ 38g



Model S78C / H10  
Type: QR Seat Clamp  
Material: AL6061  
Clamp Diam: 31.8, 34.9mm  
Weight: 28g , 30g , 17.6g , 18.9g



Model A101/ A102  
Axle Length (L): 108/ 136 , 140 , 145  
Material: Steel  
Weight:100g/ 400g



Model F99-AYAK / R99-AYAK  
-LED Light + QR  
-Waterproof  
Weight:49g/ 54g



Model F90-AYAK / R90-AYAK  
-Tire Remover + QR  
Weight:64g/ 71g

Type: Hub QR/M5  
Material: Alloy Lever, Cr-Mo or **Ti** Axle  
Front Length (L): 109, 112, 115 mm  
Rear Length (L): 144, 148.5, 151.5 mm

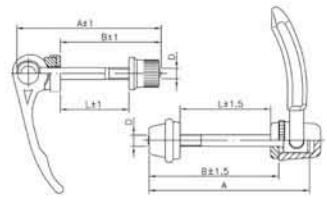
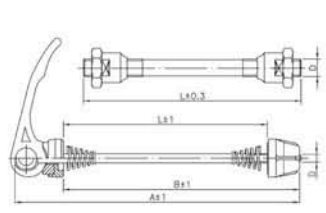



**GEN YAW**  
**景耀**

**Seat Pin Bolts**

- GY-420A ~ C (Size: M8L35~60)
- GY-320A (Size: M8 x 19,22,25)

- Model: 8200-1, 8200-2, 8100-1, 8100-2  
(Screw set for stem)  
Size: M8 x100 ~ 265 mm



**HUB Q.R & hollow axle**

- GY-401 F/R (M9x108, M10x136,140,145)
- GY-400 F/R (M5x128,165....Size to order)
- GY-420 D1 (M9x116x158L)
- GY-711 & 712 (light cargo) M5x109/ 144, M5x112/ 148mm
- GY-601 & 602, 701, 702 (M5x126,128,160,165,170)



**Clamp & Q.R SET (Alloy, Steel)**

- Model: 420A,420C 410A, 460C, 470B, 470D1,470D2, 470G2,460F, 450B, 321,941, 912
- Size:(M6, M8x45~65)25.4, 28.6, 31.8, 34.9, 38.1mm



**B.B & Crank bolts**

- Model: #GY-A2/A3/A4/A5/340A
- Size:M8x15/25mm, TM10x13L,M15x13L , Ø9.4x42L

**All kinds of pull pin**

- Pull Fixed Knob (P100-D40)
- Pull Pin (GY-P11, P11-2,P11-3,P11-S,P001-D)
- Pull Knob(P001A,P001F,P001T,P009)





官網行動go014723  
掃描QR-Code 立即線上訂購

## Brake Adjustment Screw & Wire Trap

Model:GY-360A~W



## All Kinds Screws

Model:GY-200 Material:Stainless SCM 435 / Alloy 7075 / 6061



## All Kinds Washers

Model:GY-10A~Z (size to order)  
Material:Steel/Stainless/Nylon/PVC /Alloy/Rubber...

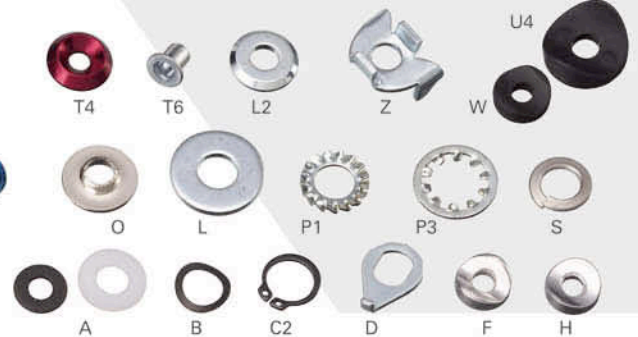

## Mutual To Lock Bolt

Model:GY-320B~K  
Size:Ø5,Ø6,Ø6.2,Ø10mm



Model:GY-320R1~R5 (Chain wheel & dropouts bolts)  
Size:M8-P 0.75x5L,6.5L,8.5L,10L/12.5L/14L  
Material:Cr-mo/Alloy/Stainless

## Water Bottle Bolt

Model:GY-200 K1~K7 Model:GY-200L3,S,J2,H,U2  
Material: Alloy7075 / Stainless /Cr-mo  
Size:M5x10~20mm



## Fender/Luggage Carriers bolt

#A9,A11,A4-W,N,S

#A1-1/2/3(Adjustment chain set)  
(Ø10 & Ø12xM6)



## All Kinds Nut





## All Kinds Of Tool



## Tools



## Adjustable Hand lever



## Two Color Knobs

- Model: K170 Size: D27,38,55xM4~M12
- Model: K110 Size: D30,50,65xM4~M12
- Model: K120 Size: D39xM4,M5,M6,M8
- Model: K200 Size: D31,50,66xM4~M12
- Model: K240 Size: L68xM5~M10mm

Color: Black, Orange, Gray, Yellow, Blue, Red, Green  
Material: Nylon glass fiber & ABS



## Hand Knobs

- Material: Nylon (PA6)
- Head Trail Size: 16 ~ 65mm
- Tread size: M4~M12



## All Kinds of tube end plugs



## Screw & Nut Cap Nylon tube washer



Visit [www.gen-yaw.com](http://www.gen-yaw.com) for full product range.....

(Q/R, TOOL, SPANNER, BOLT, NUT, PLASTIC PRODUCTS.....) Size To Order



More Products here.  
Welcome to browse it!

### Styling Clamping Knobs

Every Product  
Has Two Types Of Screws and Nuts.

We pioneered the **color matching** and the **style design** for Styling Clamping Knobs in the world.



### Adjustable Handles

There is a **stronger design** inside for UJEN's Adjustable Handles to be firm and durable.



### Mini Thin Type Clamping Knobs

They're designed with special attention to **ergonomics**, making fastening easier. It's the best choice to replace normal nuts & screws.



### Indexing Plungers

UJEN's Indexing Plungers are used to adjust to a good position fast. There are many surfaces of knobs and 4 classifications of **different additional function** with them.

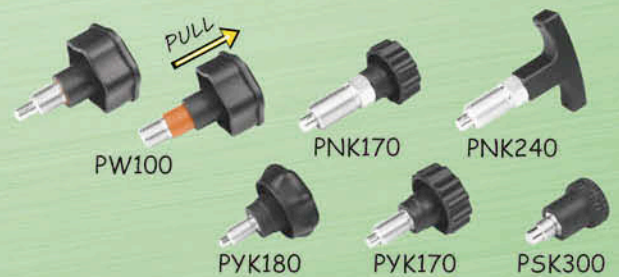



**HANGKUANG HARDWARE ENTERPRISE LTD.**  
 No.212, Wuquan 5th St., West Dist.,  
 Taichung City 403, Taiwan  
 Tel: 886-4-23731590, 23731592  
 Fax: 886-4-23726164 Executive: C.H. Yang  
 E-mail: aa2373@ms71.hinet.net

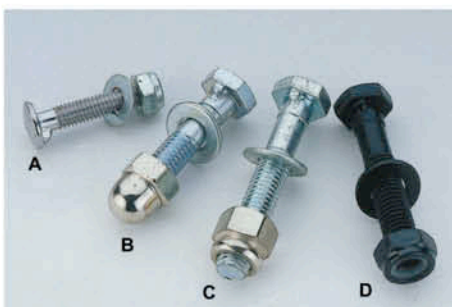

**Model HK-007**  
 For seat pillar.  
 A size: 6 x 26, 30mm.  
 B size: 8 x 1.25 x 32, 35, 38, 40, 45, 50, 55mm.



**Model HK-008**  
 Seat pillar pins(cr-mo).  
 Size: A: 8 x 19, 22, 25, 30mm  
 B: 8 x 30, 32, 34, 36, 40-56, 91mm  
 C: 12 x 55mm



**Model HK-011**  
 Bottle bolt  
 Size: M5xP0.8 x10, 12, 15mm  
 D: M8-1.0 x 25  
 F: Alloy 6061 5 x 15

**HK-011C**  
 STAINLESS  
 large head  
 hex/allen cap  
 screws  
 W3 threaded  
 M5 x P0.8  
 M6 x P1.0



**HK-011E**  
 ALLOY  
 Size: 5x8 / 5x12 / 5x15  
 Color to order



**Model HK-011G**  
 waist - shaped screw  
 hex/allen, M5 threaded  
 M5 x P0.8  
 M6 x P1.0

**Model HK-011H**  
 Aluminum#7075  
 M5-0.8 x 15, 20

**Model HK-011I**  
 Aluminum#2024  
 M5-0.8 x 8/12, 15, 20

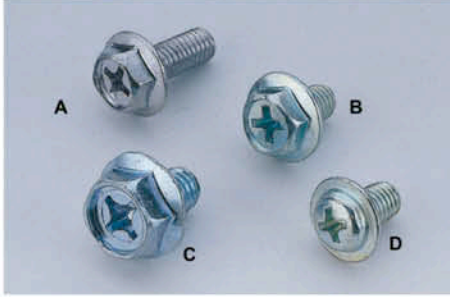

**Model HK-012**  
 Size: M5 x 8, 10, 12, 15mm.  
 M6 x 8, 10, 12, 15mm.

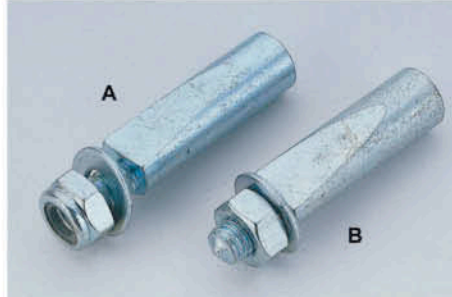

**Model HK-013**  
 Crank cotter pin.  
 Size: 42 x 9.0, 9.3, 9.5mm.



**Model HK-014**  
 Stainless steel bolt.  
 Size: M6 x 10 ~ M6 x 50mm.

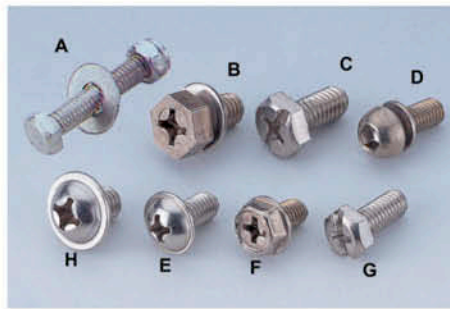

**Model HK-015**  
 Stainless steel bolt.  
 Size: M5 x 8, 10, 10, 12, 15mm.  
 M6 x 8, 10, 12mm.



**HK-015I**  
**HK-015J**  
**HK-015K**  
**HK-015L**



**HK-015O**  
**HK-015M**  
**HK-015N**  
**HK-015P**  
**HK-015Q**  
**HK-015R**  
**HK-015S**



**HANGKUANG HARDWARE  
ENTERPRISE LTD.**

**Model HK-016**

Scotter bolts.  
Size: M6 x 20 ~ M6 x 40.

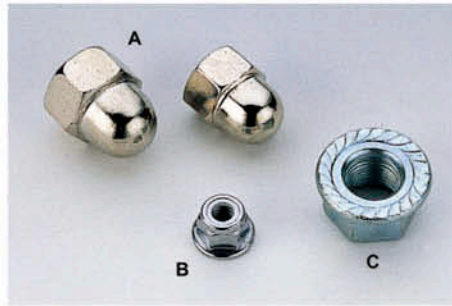

**Model HK-017**

A: Cap nut: 3/8 x 26T/24T (Stainless).  
B: Nylon nut.  
C: Flange nut.  
A, B: Size: 3/8, 5/16.  
C: M5, M6, M8.



**Model HK-031**

A:  $\Phi$  35x  $\Phi$  40x2.5  
 $\Phi$  35x  $\Phi$  40x1  
B: 3/8x21, 3/8x36  
M14x6x30  
K: 34x 28.6x 2.5/5/10

**Model:HK-AL031A**

Material:AL6061T6  
Dia:25.6 / 28.8mm  
Length:2.0 / 3.0 / 4.0 / 5.0  
7.0 / 8.0 / 9.0 / 100mm  
Finish:Black

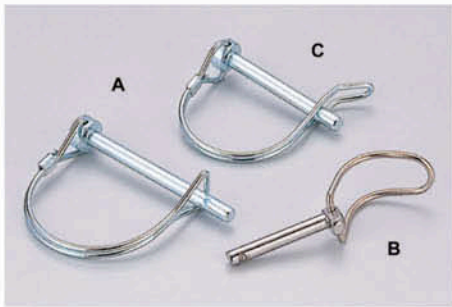

**Model HK-019**

Safety pin.  
Size: M6, M8.



**Model HK-020**

Hex key wrench set with ring.



**Model:HK-035A** Anti-theft screws

**HK-035B** Anti-theft nuts

**HK-035C** Plum anti-theft tools

**HK-035D** Sleeve tool ,M5/6/8/10



**Model HK-030**

**CAP NUT: 3/8"-26/24T**

M9-1.0  
M8-1.25  
Stainless

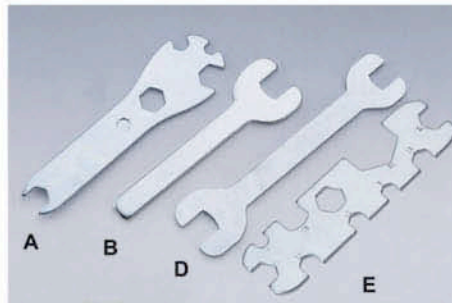

**Model HK-024**

Muti-function spanner.  
Made of steel, u-c-pfinish.  
B: M15  
D: M15x13  
E: 8 x 10 x 11 x 12 x 13 x 14 x 15 x 30



**Model:HK-032 A,B,C**

STEEL

**Model:HK-032D**

ALLOY



**Model HK-026-8**

"O" spoke adjuster.  
Made of steel, c-p finish.

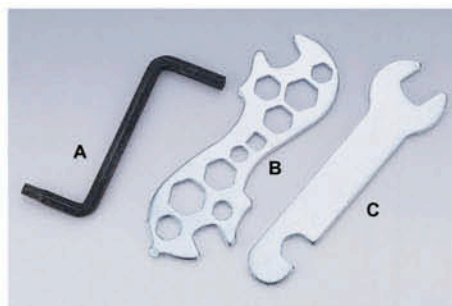

**Model HK-027**

A: Hex key wrench.  
B: 12-way spanner.  
Made of steel, u-c-p finish.

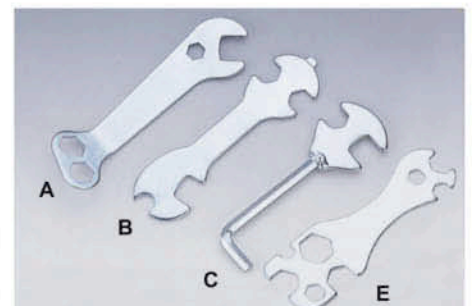

**Model HK-028**

4-way spanner.  
Made of steel, u-c-p finish.  
E: 8 x 10 x 12 x 13 x 15 x 17

# HANGKUANG HARDWARE ENTERPRISE LTD.

No.212, Wuquan 5th St., West Dist., Taichung City 403, Taiwan

Tel: 886-4-23731590, 23731592

Fax: 886-4-23726164

E-mail: aa2373@ms71.hinet.net



● **Item No: HK-050A**  
Material:AL6061T6  
Bolt:Cr-mo  
Dia:28.6 / 31.8 / 34.9mm  
Length:13.0mm  
Finish:Silver OR ED Black



● **Item No: HK-050B**  
Material:AL6061T6  
Bolt:Cr-mo  
Dia:28.6 / 31.8 / 34.9mm  
Length:13.0mm  
Finish:Silver OR ED Black



● **Item No: HK-050C**  
Material:AL6061T6Forged  
Bolt:Cr-mo  
Dia:28.6 / 31.8 / 34.9mm  
Length:15.0mm  
Finish:Silver OR ED Black



● **Item No: HK-050D**  
Material:AL6061T6NC  
Bolt:Cr-mo  
Dia: 31.8 / 34.9mm  
Length:11.0mm  
Finish:Silver OR ED Black



● **Item No: HK-050E**  
Material:AL6061T6Full CNC  
Bolt:Cr-mo  
Dia:31.8 / 34.9 / 36.0mm  
Length:14.0mm  
Finish:Silver OR ED Black



● **Item No: HK-050F**  
Material:AL6061T6 Full CNC  
Bolt:Cr-mo  
Dia:31.8 / 34.9 / 36.0mm  
Length:21.0mm  
Finish:Silver OR ED Black



● **Item No: HK-050G**  
Material:AL6061T6 Full CNC  
Bolt:Cr-mo  
Dia: 34.9mm  
Length:20.0mm  
Finish:Silver OR ED Black



● **Item No: HK-050H**  
Material:AL6061T6 Full CNC  
Bolt:Cr-mo  
Dia:31.8+27.2,31.8+28.6,  
34.9+31.8mm  
Length:21.5mm  
Finish:Silver OR ED Black



● **Item No: HK-050I**  
Material:AL6061T6 Forged  
Bolt:Cr-mo  
Dia: 34.9mm  
Length:14.0mm  
Finish:Silver OR ED Black



● **Item No: HK-050J**  
Material:AL6061T6 Forged  
Bolt:Cr-mo  
Dia: 28.6 / 31.8mm  
Length:13.0mm  
Finish:Silver OR ED Black



● **Item No: HK-050K**  
Material:AL6061T6  
Bolt:Cr-mo  
Dia: 31.8 / 34.9mm  
Length:15.0mm  
Finish:Silver OR ED Black



● **Item No: HK-051A**  
Material:AL6061T6  
Bolt:Cr-mo  
Dia:28.6 / 31.8 / 34.9mm  
Length:13.0mm  
Finish:Silver OR ED Black



● **Item No: HK-051B**  
Material:AL6061T6  
Bolt:Cr-mo  
Dia:28.6 / 31.8 / 34.9mm  
Length:13.0mm  
Finish:Silver OR ED Black



● **Item No: HK-051C**  
Material:AL6061T6  
Bolt:Cr-mo  
Dia:28.6 / 31.8 / 34.9mm  
Length:13.0mm  
Finish:Silver OR ED Black



● **Item No: HK-051I**  
Material:AL6061T6  
Bolt:Cr-mo  
Dia:28.6 / 31.8 / 34.9mm  
Length:13.0mm  
Finish:Silver OR ED Black



● **Item No: HK-051E**  
Material:AL6061T6Lever NC  
Bolt:Cr-mo  
Dia:28.6 / 31.8 / 34.9mm  
Length:13.0mm  
Finish:Silver OR ED Black



● **Item No: HK-051F**  
Material:AL6061T6 Lever NC  
Bolt:Cr-mo  
Dia:28.6 / 31.8 / 34.9mm  
Length:13.0mm  
Finish:Silver OR ED Black



● **Item No: HK-051G**  
Material:AL6061T6  
Bolt:Cr-mo  
Dia:28.6 / 31.8 / 34.9mm  
Length:13.0mm  
Finish:Silver OR ED Black



● **Item No: HK-051H**  
Material:AL6061T6 Lever NC  
Bolt:Cr-mo  
Dia: 31.8mm  
Length:13.0mm  
Finish:Silver OR ED Black



● **Item No: HK-AL003**  
Material:3K Carbon Fiber  
Dia:25.6 / 28.8mm  
Length:2.0 / 3.0 / 4.0 / 5.0 /  
7.0 / 8.0 / 9.0 / 10.0mm  
Finish:Black

we are specialist manufacturer of Titanium Alloy and act as a supplier to several major bicycle companies. About technical, we use turnery, die casting and CNC on Titanium Alloy that meet customer's requirement. If you have any questions please don't hesitate to contact us.

家豐榮有限公司 HI BIKE LTD

Tel: +886-4-23358820

Mail: sales@hibike.com.tw

# TITANIUM BIKE PARTS / BOLT

## ULTRA LIGHT



TPV-001 TBT-002 TBI-001 TBT-003 TBC-002 TBS-001 TBH-001 TBC-001 TBT-001 TBS-002 TAX-002 TBB-001

Type of head & size can be customized.  
Pls offer your drawing or just fill out below blank,  
and then we will submit the best price to you soon.

### TYPE OF HEAD 螺絲頭型

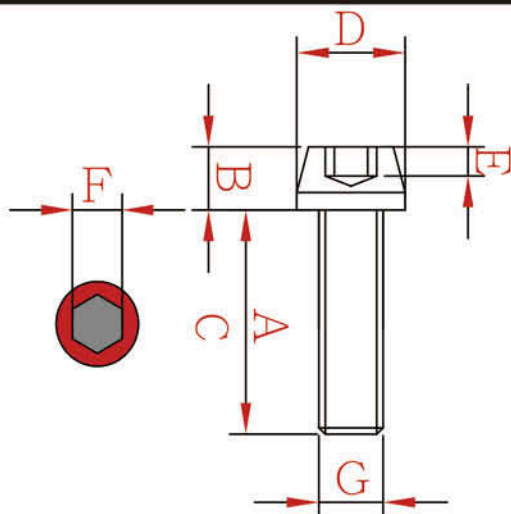
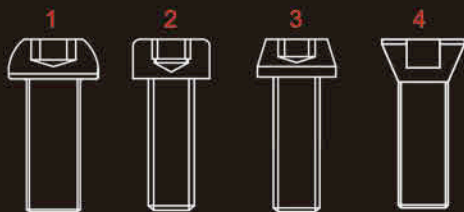

Position	Description	Size (mm)
A	bolt length	長度標示
B	head height	頭型高度
C	tooth length	牙紋標示
D	head diameter	頭形直徑
E	hex depth	六角深度
F	hex size	六角尺寸
G	screw diameter	螺絲直徑
H	type of head	螺絲頭型

- ★ Reduces the need for large spoke stock.
- ★ 14 & 15 gauge compatible.
- ★ Total cycle time: 7 seconds.
- ★ Spokes can be cut to any length.
- ★ 10,000pc. replaceable cutting die

MADE IN JAPAN

## SPOKE CUTTER

鋼絲裁剪滾牙機

### BIKE SHOP TOOL

12/13 gauge  
13/14 gauge  
14/15 gauge





**JUNN CHERNG CO.LTD.**  
 Add:No.307, Tung Kuang Rd., Kan Ching Li,  
 Ho Mei Town, Changhua Hsien, Taiwan.  
 Tel:886-4-755-9296,7562892  
 Fax: 886-4-7560393  
 E-mail: n7562699@ms45.hinet.net  
 http://www.jiuncherng.com.tw  
 Excutive: C.H.Lin



**CH16-1S / CH16-1A / CH16-2A / CH16-2AS**  
 Hub Q.R M5, Axle is Cr-Mo  
**CH16-1S:** w/steel nut      **CH16-1A:** w/Alloy nut  
**CH16-2A:** w/Alloy nut      **CH16-2AS:**w/Alloy nut  
**CH17:** Hex Key Wrench



**CH101R/CH101F**  
 Alloy forged QR, w/out bent level in scale similar as SHIMANO steel QR. Locating. Cr-Mo CP skewer w/steel washer nut.

*\*All this series type can add "-1" at end of item No. in different washer type as shown below.*

**CH103R/CH103F**  
 Alloy forged QR, handy level style. Cr-Mo CP skewer w/steel washer

**CH102R/CH102F, CH104R/CH104F**  
 Alloy QR, handy level style, Cr-Mo CP skewer w/steel washer



**CH101R-1/CH101F-1**  
 Alloy forged QR, w/out bent level in scale similar as SHIMANO steel QR. Cr-Mo CP skewer w/steel washer nut.

**CH102R-1/CH102F-1**  
 Alloy QR, handy level style, Cr-Mo CP skewer w/steel washer

**CH102R-1T/CH102F-1T**(Example equipped shown)  
 Alloy QR, all available swing skewer as Ti. Marked "T" at last of QR item No. (T=titanium)

**CH104R-2E/CH104F-2E**  
 Alloy QR, all available cost down w/no steel washer and Phos. plated skewer. Marked "E" at last of each QR item No. (E=economical)



Custom package/logo assigned are welcome

CH55A

CH55A-1

CH55A-2

**JIUNN CHERNG CO., LTD.**

**CH55A/55A-1/55A-2**

Alloy Front/Rear/set pin

Quick Release

Cold forged (Axle: Cr-Mo/Titanium optional choice available)

CH-55A-2: 6mm

3 pcs in one package  
Can be used on any model



Custom package/logo assigned are welcome

CH55T

CH55T-1

CH55T-2

**CH55T/55T-1/55T-2**

Alloy Front/Rear/set pin

Quick Release

Cold forged (Axle: Cr-Mo/Titanium optional choice available)

CH-55T-2: 6mm

Size to order

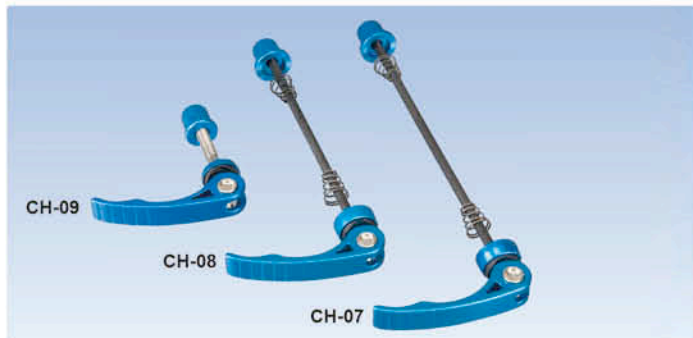

CH-09

CH-08

CH-07

**CH-07, CH-08, CH-09**

Alloy front/rear/seat pin QR set. w/assigned anodized colors available.



Custom package/logo assigned are welcome

CH53A

CH53A-1

**CH53A / CH53A-1**

Alloy Front / Rear Quick Release.

(Axle: Cr-Mo/Titanium optional choice available)

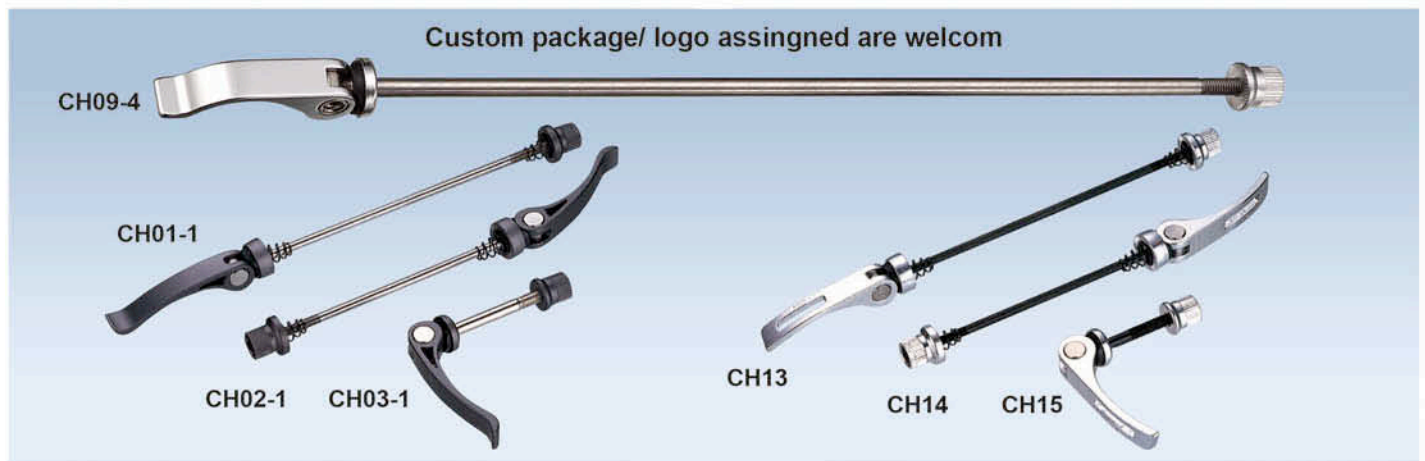

Custom package/ logo assigned are welcome

CH09-4

CH01-1

CH02-1

CH03-1

CH13

CH14

CH15

**CH01-1 / 02-1 / 03-1**

Alloy front / rear / seat pin. Quick release .

(Axle: Cr-Mo/Titanium)

CH03-1: 6mm~8mm

**CH13 / 14 / 15**

Alloy front / rear / seat pin. Quick release .

CH15: 6mm~8mm available.

**CH09-4**

Alloy quick release / Lever: aluminum handle

Bolt: stainless steel 303

Nut: stainless steel 303 or aluminum

Dia: M6/M8 / L:384mm / size: to order



CH36

CH37

CH35

**CH35 / 36 / 37**

steel seat pin quick release

lever nut fasten.

Diam: XL=6mm, 8mm x 45/50/55/60

Lever by C ring fastened

(not shown on picture)



CH28

CH30

CH25

CH26

**CH28 / 30 / 25 / 26**

Steel front / rear quick release.

L: 121/126/128/155/165mm.

Hollow axle quick release hub type.

Front L: 9x101x108mm. for CH26

Rear L: 10x134x136x140x145mm. for CH25



CH-01-2

CH-02-2

CH-27-1

CH-29-1

**CH-27-1 / 29-1 / 01-2 / 02-2**

Hub front/rear quick release

L:121/126/128/155/165mm





**CH70A / 70B / 70D**  
Steel clamp for saddle  
CH70A / with safety hook  
CH70D /with carriage bolt



**F105** Alloy forged chain tensioner for 1/2",M14 axle,  
(**MF105**-Dual tone machined)  
**F105** Alloy forged chain tensioner for 3/8",M10 axle,  
(**MF105-1**-Dual tone machined)



**D105-10** Steel made single pull chain tensioner for 3/8, M10 axle  
**D105-14** Steel made single pull chain tensioner for 1/2, M14 axle  
**A105-10** Alloy chain tensioner for 3/8, M10 axle



**CH21/ 21-1/ 21-2/ 21-3/ 24/ 24-1/ 59-1**  
Alloy seat pin clamp for MTB, Scooter bike.  
Diam.:25.4~34.9mm  
size to order.



**F101-1** 3 speed internal gear set, 13 / 32" x 26T Size to order.  
All famous brand's internal gear shaft, accessories in custom order available



**CH2352A**  
Spindle sets (Cr-Mo), M14, 10 piece parts.  
**CH2352P**  
Spindle sets (Cr-Mo), M14, 7 piece parts.  
Size to order.  
**2352**  
Spindle sets (Cr-Mo-BK), M14, 7 piece parts.  
Size to order



**66A/66B**  
CH66A For sturmey-archer; 3-SP hub length: 135mm  
CH66B For sturmey-archer; 3-SP hub. (5-SP optional) Length: 126 mm  
**2340A/2340B**  
2340A 13/32"-26T/1007, 1008:Axle nuts for sturmey-Archer 3-SP hub  
U.C.P. finished; 2340B 13/32"-26T1009,  
1010 Axle nuts Torpedo F & S 3-S Phub.; U.C.P. finished



**CH69 / CH69-1**  
Steel clamp for seat post.  
Dia: 25.4mm / 28.6mm / 31.8mm  
CH69-1: Steel QR  
**CH70C**  
Steel saddle clamp w/inner post clips  
to reinforce gripping power



**CH58C**  
Bicycle spoke beads assorted color



**Strapped hanging card/plastic bag H. card**  
For Chain tensioner package  
or other assigned parts upon order.  
Either pair on strapped card  
or bagged upon order available.



**F105-2** Anti-scratching heavy load nut-  
(w/rotatable buckled washer)  
Dimensions:14x1.0, 1/2",  
M9 & M10x1.0,  
24T/26T x3/8, 24T/26T x 5/16



### Model 2350

Front hub brake spindle 3/8 x 140mm

### Model 2351

Rear hub brake spindle 3/8x165mm, 175mm



### Model 2317A, 2318A, 2319A

2317A: Front spindle with dust cap.  
5/16" or 3/8" x 130mm, 140mm.

2318A: Rear spindle with dust cap.  
3/8" x 165mm, 175mm.

2319A: Rear spindle for 10-speed with dust cap.  
3/8" x 165mm, 175mm.

Custom pressed logo & custom style  
inner box assignments are welcome



Hub spindles inner box



### 2315, 2316, 2317, 2318

2315: Front spindle.  
5/16" or 3/8" x 130mm 140mm.

2316: Rear spindle.  
3/8" x 165mm, 175mm

2317: Front spindle.  
5/16" or 3/8" x 130T, 140mm.

2318: Rear spindle.  
3/8 x 165mm, 175mm.



### 2311, 2312, 2313, 2314

2311: Front spindle.  
5/16" or 3/8" x 130mm, 140mm.

2312: Rear spindle.  
3/8" x 165mm, 175mm

2313: Front spindle.  
5/16" or 3/8" x 130mm, 140mm.

2314: Rear spindle.  
3/8 x 165mm, 175mm.



### 2319, 2321, 2320, 2322, 2323A

2319: Rear spindle, For 10 speed.  
3/8" x 165mm 175mm, 185mm.

2320: Front spindle.  
5/16" x 130mm, 140mm

2321: Rear spindle.  
3/8" x 165mm.

2322: Coaster hub axle, self-color, 3/8" x 182mm.  
2323A: Coaster hub axle.  
3/8" x 163, 175mm.



### 2324/2325/2324QR/2325QR/2339

2324: Front hub cone. 5/16".

2325: Rear hub cone. 3/8", M14, 1/2"

2324QR: Front hub cone for QR M9

2325QR: Rear hub cone for QR M10

2339: Rear Philips cone.

### 2326/2326B/2327/2328/2329

2326: Rear hub cone. 3/8"

2326B: Front hub cone. 5/16"

2327: Rear hub cone. 3/8"

2328: Front hub cone. 5/16"

2329: Rear hub cone. 3/8".



### 2340

(C) Hub safety washer.

(D) Front lock nut, 5/16".

(E) Rear lock nut, 3/8".

(G) Cotterless nut.

(H) Hub spacer.

(F) Size M6X 38, 40, 45mm

(I) Size: 8x1.25x35, 38, 40, 45, 50, 55mm  
Optional pair with cap nut or nylon nut upon order

(J) Cap nut 3/8x26T/24T, 5/16x26T/24T

M9&M10XP1.0



### 2336, 2337, 2338

2336: Front flange cup 5/16".

Rear flange cup 3/8".

2337: Rear hub cup 3/8".

2338: Front hub cup 5/16".

Rear hub cup 3/8".

### 2332, 2333, 2334, 2335

2332: Front hub nut.

2333: Rear hub nut 3/8" x 26T.

2334: Front nut and washer.

5/16" x 26T, 24T.

2335: Rear nut and washer.

3/8 x 26T x 24T.

M14, 1/2".

**LAMINAR ENT. CO. LTD.  
LAGEAR ENT. CO., LTD.**

No.167-3, Ln. 92, Fengnan St.,  
Fengyuan Dist.,  
Taichung City 42052, Taiwan  
Tel: +886-4-25391989  
Fax: +886-4-25391973  
E-mail: primaero@ms35.hinet.net  
[www.mrcontrol-bike.com](http://www.mrcontrol-bike.com)



TK-TD18



ACE-28.6-H



AC-28.6-H



TK-009C-T  
(TK-009C)



ATR-28.6-5



AR-28.6-H



QR-SPOT/F/R/RC



QR-FLV-12X/15X (C2)



QR-MF5-12X/15X (C2)



QR-KM2



QR-K



QR-SPAX



CL-CV



CL-FDG3



CL-KE06-CV



CL-DDM273



CL-FJ21-2



CL-H2C-2

**PROMOTION**



CL-07

**Compatible:**



ADP-COMBO



Garmin



PoLar



Giant



Mio



Wahoo



Byton



GoPro



ADP-RSCAP



ADP-SRM-PC8



ADP-ORG26



AR-286-GP1



ADP-GP-X2

Available in different cycling computer and camera / light mount.

**E-BIKE**



ADP-SHE8

Speed sensor adapter



ADP-SHE8-H



TRSK-BSH



M-LK-BSH



CH-E8-MINI

For SHIMANO® E8000 chain guide.

**CHAIN GUIDE**



CH-DDS1-MINI



CH-CM1-E



CH-M1-MED



CH-R1-MINI



STEM-25



HB-ECT780C-D2



SPC-SL6



JULY-7905-CNC



SSP-105-152X



WB-R1-17C



P.A.T.  
WB-G201



ADP-SH2



CX-MUTI



CX-1042S



NZ-GH



**" YOU GOT THE BEST PROTECTION AND SERVICE FROM MR.CONTROL TEAM, AND YOU PAY ONLY: CONTACT US TO GET MORE SUPPORT, IDEAS AND NEW TECHNOLOGY. "**





US Patented : 8,573,879 B2  
Taiwan Patent : M 425185  
360° Fine-tuning Quick Release  
Rotating adjustment mechanism  
Adjustable at any angle

**Auto Invisible Handle  
Pat Pending**



**Rotating Adjustment  
Pat Patent**

REX Ø12 AND Ø15

**Allen Key Hollow Axle**



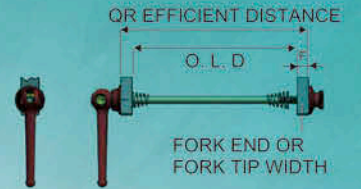

Material: Alloy / Axle: CR-MO(CP), STAINLESS, TI  
F-Efficient Distance: 5mm x 108, 112, 114  
R-Efficient Distance: 5mm x 143, 148, 151



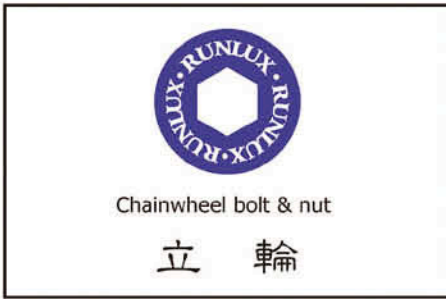

RUNLUX HARDWARE CO., LTD.  
 No. 334, Fu Te 1 Rd., Hsichih City, Taipei  
 County, Taiwan.  
 Tel: 886-2-26947942, 886-2-26942163  
 Fax: 886-2-26947314  
 http://www.runlux.com.tw  
 E-mail: runlux@runlux.com.tw



We are specialized in producing bicycle chain wheel bolts as well as axle bolts. Our manufacturer have strict quality, efficiency and management to maintain professional skill and provide our customers with good quality products.

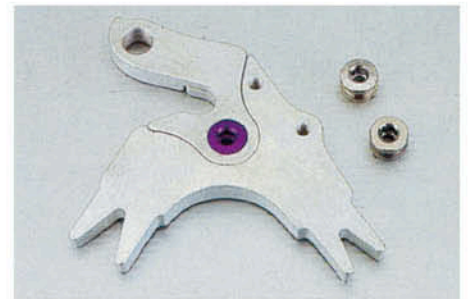

Model: RDB-805C / S / AL  
 Rear dropout bolt and nut  
 Material: C ~ Cr-Mo (SCM-435)  
 S ~ stainless steel (SUS-302)  
 AL ~ alloy aluminum 7075  
 Size: M8-0.75 x 5.0L



Model RCB-1513A (A-alloy cap)  
 RCB-1513B (Plastic cap)  
 Material: Cr-Mo (SCM-435)  
 Size: M15-1.0 x 13L



Model: (1)RCB-815N ~ alloy cap (2)RCB-815AL ~ alloy cap  
 (3)RCB-815S ~ plastic cap (4)RCB-815 ~ plastic cap  
 Material: (1) & (4) Cr-Mo (SCM-435) (2)aluminum7075 (3) stainless steel (SUS-302)  
 Size: M8 -1.0 x 15L

Cotterless Axle Bolt for Chainwheel



Model: RCW-065C/S/AL (M8-0.75 x 6.5L)  
 RCW-085C/S/AL (M8-0.75 x 8.5L)  
 RCW-125C/S/AL (M8-0.75 x 12.5L)  
 Material: C ~ Cr-Mo (SCM-435)  
 S ~ stainless steel (SUS-302)  
 AL ~ aluminum 7075  
 \*\*\*\*\* ALL SIZE ARE AVAILABLE \*\*\*\*\*



Model: RCW-M8.5  
 Material: Cr-Mo (SCM-435)  
 Size: M8.5 - 0.75 x 5.0L



Model: RCW-085AL (torx)  
 Material: aluminum 7075  
 Size: M8 - 0.75 x 8.5L



(1)RCB-P815: M8-1.0x15(plastic cap)  
 (2)RCB-P1513B: M15-1.0x13L (plastic cap)  
 Material: Cr-Mo (SCM-435)



(1)RCW-P101C/S/AL: for single chainwheel (BMX) M8-0.75x6.5L  
 (2)RCW-P102C/S/AL: for double chainwheel (Trekking) M8-0.75x8.5L  
 (3)RCW-P103C/S/AL: for triple chainwheel (Mountain Bike) M8-0.75x8.5L  
 Material: C ~ Cr-Mo (SCM-435) S ~ stainless steel (SUS-302) AL ~ aluminum 7075  
 Remark: (1) P101 - 5 bolts & 5 nuts (2) P102 - 5 bolts & 5 nuts (3) P103 - 10 bolts & 5 nuts

# 嵩鈦金屬工業有限公司 SONGTAI Industrial Co., Ltd.

高雄市岡山區大莊路56號No.56, Dazhuang Rd., Gangshan Dist., Kaohsiung City 82056, Taiwan  
 TEL : 886-7-628-3626 FAX : 886-7-628-4701 Web:www.sungti.com.tw  
 E-mail:sungti2008@yahoo.com.tw

自行車鈦合金零組件、曲柄鈦軸心、大齒盤螺母組等  
 GR.5 Ti parts for bicycle, axles for pedal, crankshaft, screws of front chain wheel.



機車精品零組件鈦合金螺絲等  
 SOCKET Type High quality GR.5 Ti Screws, Bolts for motorcycle.



立管龍頭螺絲、座管螺絲、微調螺絲、快拆等自行車用鈦合金螺絲  
 GR.5 Ti Screws for head tube, seat tube, fine adjustment, and axles for quick-release, etc.



**鍛造鈦合金螺絲** GR.5 Ti Screws

**合金鋼零件設計製造** Alloy steel parts design and manufacture

**鍛造鈦合金零件** GR.5 Ti Parts

**客製化生產** Custom design for specific demand



汽車輪胎精品螺絲、軸心  
 Screws for crankshaft of motor tyre



DIN912 機械用特殊螺絲  
 Mechanical use Special Bolts, Screws

機車精品零組件鈦合金螺絲、六角螺帽、六角側孔螺絲等  
 HEX. + SOCKET type High quality GR.5 Ti Parts, Screws, Hex. nuts., etc.

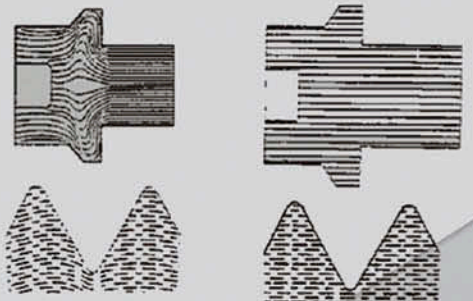

(A)鍛造滾牙螺絲具連續性鍛流線 (B)切創螺絲之鍛流線

## 鈦合金產品特性 The feature of our Ti alloy Products

- 1.棒材統一來源:航太認證(國際級大廠提供),棒材皆經ET.UT(AMS2631B CLASS A1)嚴格檢驗(可附材證)。
- 2.經鍛造及滾牙所製作之鈦螺絲,具有平順之鍛流線,產品可抗剪強度、疲勞強度較佳,再配合CNC,加工更具美觀價值感。
- 3.敝司產品具保有高額產品責任險(Product Insurance)、使用者更安心。可代客發色、耐落,歡迎來電洽詢。

## 生產流程 Production Flow Chart

純鈦:ASTM B348- Gr. 1, 2, 3, 4 鈦合金:ASTM B348 及 AMS 4928-Ti6Al4V(GR.5)



螺絲、螺栓、軸心...等精緻成品  
 (Ti and Ti alloy fine products Parts)





SP-03-01 M5 X 160,165	SP-05-01 Alloy M5 X 160,165	SP-09-01 M14 X 165,175,185	SP-11-01 3/16 X 7	SP-13-01 3/8 REAR HUB CONE	SP-13-13 5/16 FRONT NUT	SP-15-01 12.7 x 35 x 9.5 13-A	SP-17-01 1/8	SP-19-01 5/16 1.6x25x10L
SP-03-03 M5 X 126,128	SP-05-03 Alloy M5 X 126,128	SP-09-03 5/16, 3/8 X 140	SP-11-03 1/4 X 7	SP-13-03 5/16 FRONT HUB CONE	SP-13-15 3/8 REAR NUT	SP-15-03 15.9 x 35 x 9.5 13-B	SP-17-03 5/32	SP-19-03 3/8 1.8x29x12L
SP-25-011 5, 10, 15, 20MM	SP-05-05 Alloy M6 X 45	SP-09-05 3/8 X 170,175 180	SP-11-05 1/4 X 9	SP-13-05 5/16 FRONT COVER HUB CONE	SP-13-17 HUB SPACER	SP-15-05 19 x 35 x 9.5 13-C	SP-17-05 3/16	SP-19-05 5/16 1.6x25x8L
SP-27-05 COTTER PIN	SP-07-01 M9x 165	SP-09-07 3/8 X 170,175 180	SP-11-07 5/16 X 9	SP-13-07 3/8 REAR COVER HUB CONE	SP-13-19 M10 NUT WITH WASHER	SP-15-07 12.7 x 28.7 x 7.3 11-B	SP-17-09 1/4	SP-19-07 3/8 1.6x29x10L
	SP-07-03 M8 x 45 M6 x 45	SP-09-09 M9 X 108	SP-11-09 5/32 X 16	SP-13-09 3/8 NUT WITH WASHER	SP-13-21 M9 NUT	SP-15-09 6000 Z2 10 x 26 x 8		SP-19-09 3/8 2.0x29.6x13L
		SP-09-11 M10x 136,140,145	SP-11-11 5/32 X 20-1 1/8	SP-13-11 5/16 NUT WITH WASHER	SP-13-23 M10 NUT	SP-15-11 6201 Z2 12 x 28 x 8		
		SP-09-13 5/16, 3/8 X 140	SP-11-13 5/32 X 22A-1 1/8					
		SP-09-15 3/8 X 170,175,180						

沛昌國際股份有限公司  
 TEL : 04-7691139 FAX : 04-7691557  
 sales@spinup-hardware.com  
 50445彰化縣秀水鄉安東村安樂街54號一樓



鉅 特

**SUTECH ENTERPRISE CO., LTD.**  
 No.116, Ln. 1, Sec. 2,  
 Yuanshui Rd., Yuanlin City,  
 Changhua County 510,  
 Taiwan  
 Tel: 886-4-834-0318  
 Fax: 886-4-835-3215  
 Executive: George Wu  
 E-mail:su.tech@msa.hinet.net





Professional manufacturer of special screws for automotive, bicycle, motorcycle and sporting equipment. Various materials including **Aluminum, Cr-Mo, Steel, Stainless Steel, Titanium** are adopted.

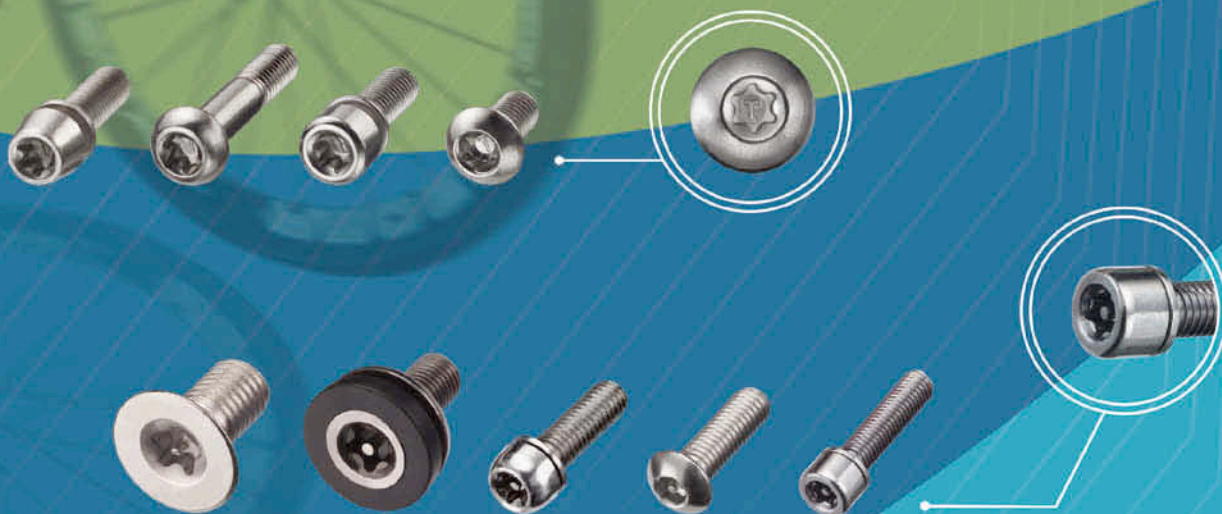

**TAI LOU METAL INDUSTRY CO., LTD.**

516彰化縣埔鹽鄉出水村埔港路33-4號

No. 33-4, Pukang Rd., Chushu Tsun, Puyen Hsieng, Changhua Hsien 516, Taiwan.

Tel: +886-4-8650430 Fax: +886-4-8654418 tailou@ms26.hinet.net www.tailou.com.tw





勇 義

Chain Wheel Bolt & Nut

# YUNNEX HARDWARE CO.,LTD.

No.8,Lane 80,Chi-Chih St.,Shu-Lin Dist.,New Taipei City,238,Taiwan

Tel:02-26819922, 26818815, 26832551-3

Fax:886-2-26822416 E-mail:wu20110815@gmail.com

B14



**YCW-8.5(M8.5-0.75x 5L)**

**YCW-8.5(M8.5-0.75x 6L)**

Material:Alloy 7075  
Big One & Middle Chainwheel Use



**YCW-T30(M10-0.75x7.0L)**

Material:Alloy 7075  
Chainwheel Use



**YCW-065AL T30(M8-0.75x 6.5L)**

**YCW-085AL T30(M8-0.75x 8.5L)**

Material:Alloy 7075

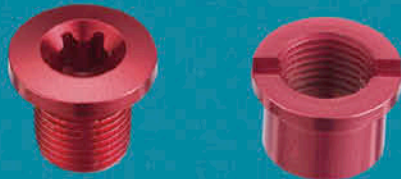

**YCW-101 T30AL**

Bolt (M8-0.75x6.5L) 5 sets & Nut (9.9x4.0L) 5 sets

**YCW-201 T30AL**

Bolt (M8-0.75x8.5L) 5 sets & Nut (9.9x7.0L) 5 sets

**YCW-301 T30AL**

Bolt (M8-0.75x8.5L) 10 sets & Nut (9.9x7.0L) 5 sets



**YCW-065 (M8-0.75x 6.5L)**

Material:Alloy 7075 (YCW-065AL)  
Stainless steel (YCW-065S)  
Cr-Mo (YCW-065C)



**YCW-085 (M8-0.75x 8.5L)**

Material:Alloy 7075 (YCW-085AL)  
Stainless steel (YCW-085S)  
Cr-Mo (YCW-085C)



**YCW-101 (AL/S/C)**

Bolt (M8-0.75x6.5L) 5 sets & Nut (9.9x4.0L) 5 sets

**YCW-201 (AL/S/C)**

Bolt (M8-0.75x8.5L) 5 sets & Nut (9.9x7.0L) 5 sets

**YCW-301 (AL/S/C)**

Bolt (M8-0.75x8.5L) 10 sets & Nut (9.9x7.0L) 5 sets  
AL:Alloy aluminum / S: Stainless steel / C:Cr-Mo



**YCW-1513(M15-1.0x13L)**

Cotterless axle bolts  
(M15-1.0x13L)  
Material: Cr-Mo



**YCW-052AL(M8-0.75x5.2L)**



**YCW-052S(M8-0.75x5.2L)**

**YCW-052C(M8-0.75x5.2L)**

**YCW-815(M8-1.0x15L)**

Cotterless axle bolts  
(M8-1.0x15L)  
Material:Stainless steel (YCW-815S)  
Cr-Mo (YCW-815C)



**A Bolt(M8-0.75x7.5L)**

Nut (12-9.85x6.5L)  
Material: Cr-Mo



**B Bolt(M8-0.75x5.0L)**

Nut (12-9.85x7.0L)  
Material: Cr-Mo



**C**

Spacer for chainring use  
Material: AL 6061  
(M14x10.5)



**D**

Rivets for chainring use  
Material: Stainless steel SUS303



**CUSTOMIZATION FOR ANY SIZE AND COLOR !**



Model : SHL 01  
Bolts for front forks  
Size : A : M7\*125~150mm / M6\*60~300mm



Model : SHL 02  
Bolts for suspension parts  
Size : A : M10\*45~94mm  
B : 3/8\*52~75mm  
C、D、E :  $\phi$  8/M6\*12~110mm

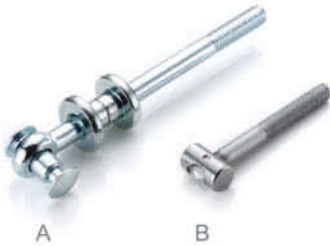

Model : SHL 03  
For seat quick release  
A、B : M5/M6 length and color is optional

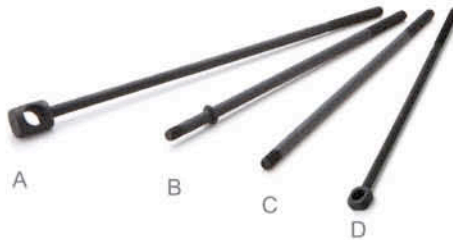

Model : SHL 04  
Bolts for front and rear quick release axle  
Size : M5\*100~300mm



Model : SHL 05  
Rear absorber and frame bolts  
Size :  $\phi$  8/M6 :  $\phi$  10、 $\phi$  12/M8  
Length is optional



Model : SHL 07  
Rivets and bolt set for chain wheel  
Size : D : M8\*0.75



Model : SHL 08  
Cotterless axle bolt for chain wheel  
Size : A、B : M8\*1.0\*15~22mm  
C : M15\*1.0\*13.5mm  
Material : SCM435 SUS304

Model : SHL 06  
Hex head and hex socket screw for stem  
Size : M8\*60~290mm  
M10\*160mm

**DONGGUAN SANHEWLETT METAL PRODUCTS CO.,LTD**

Add : The Xinqiao Industrial Zone, Tianxin Village, Huangjiang Town, Dongguan City, Guangdong Province, China.  
Tel : +86 769 83518248 Fax : +86 769 83518243

**CHEERYORK Enterprises Co.,Ltd.**

Add : Taichung City, Taiwan.  
Tel : +886 4 22518955 Fax : +886 4 22518956



Model : SHL 09  
Precision lathe parts  
Material : 6061 SUS304



Model : SHL 10  
Bolts for seat pillar and handlebar  
Size : M8\*32 ~45mm



Model : SHL 11  
Bolts for bottle cage  
Size : M5\*10~15mm



Model : SHL 12  
Bolts for seat pillar  
Size : M6/M8\*30~48mm \* Color and material is optional



Model : SHL 13  
Hex socket bolts for stem  
Size : A : M5/M6/M7/M8\*15~45mm

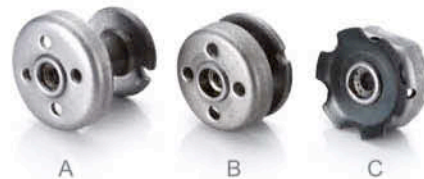

Model : SHL 14  
Expander for fork stem  
Size : M6\*10 · 18 · 30mm



Model : SHL 15  
Bolts for chain cover and fender  
Size : M5/M6\*8~50mm  
Material : Steel and stainless steel is available



Model : SHL 16  
Bolts for some other use

## LIYOU METAL PRODUCTS(TIANJIN)CO.,LTD

Add : South Jinyong Road, Shuangkou Town, Beichen District, Tianjin City, China.  
Tel : +86 22 86837818 Fax : +86 22 86837816

URL : <http://www.sanhewlett.com> ; [www.sanhewlett.com.cn](http://www.sanhewlett.com.cn)  
E-mail : [business@sanhewlett.com.cn](mailto:business@sanhewlett.com.cn) ; [sanhewlett@msn.com](mailto:sanhewlett@msn.com)

Taiwan Bicycle Source 2018-2019





伸旺車料五金（深圳）有限公司  
**WARDER (SHENZHEN) CO.,LTD**  
 地址：深圳市寶安區松崗鎮溪頭工業區松環路124號  
 No.124 Song Huan Rd.Xitou Industrial Zone,  
 Songgang Town,518105,Baoan District, Shenzhen,  
 Guangdong,China  
 Tel:+86-755-27469096/27718470/29627324  
 Fax:+86-755-29627323  
 Http:www.szshenwang.com  
 E-mail:hzp1023@163.com  
 E-mail:cw168@vip.163.com



WQR-03A



WQR-04A



WQR-02



WSC-01



WSC-03



WDB-01-2-SM



WBP-14



WDR-01-160-RD



WDA-02



WDA-11



WBG-03



WBG-05



WBG-06A



WDA-10



WBT-01

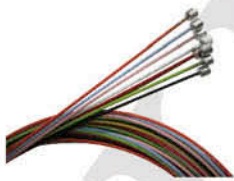

WCA-06TC



WCA-09



WCA-12



WHC-03



WHC-04



WVC-06



WVC-08A



WC-09



WC-10



WC-11



WC-12



# GEMINI BICYCLE INC. 展暉工業有限公司

Tel: +886-4-26711667  
 Fax: +886-4-26711668

No.81-2 Wenqu Rd., Dajia Dist., Taichung City 43750 Taiwan  
 Email: gemini@gbilee.tw Web: www.gbi.com.tw

## Custom Pegs

Material: Alloy, CR-MO, Plastic Length: 97-125 mm  
 Sleeve: CR-Mo, Nylon Black, PC Clear Length: 100-110 mm



AP7007AN



AP3846AP  
(Rainbow)



AP3846AN



## Custom Hub Guards



Plastic / Forging / CNC



Clamp Material: Alloy  
 Dia: 25.4/27.2/28.6/29.8 mm



## Seat Post & Clamps

Post Material: Alloy  
 Length: 135/200/300 mm



## Custom Standard/ Butted Bar

Material: CR-MO, Steel, Alloy  
 Bar Bore: 22.2/25.4/31.8 mm  
 Finish: ED, CP, Painting, Rainbow, custom

WIDTH	RISE	BACK SWEEP	UP SWEEP
21"~29"	4"~9"	9"~14"	1"~4"



## Bar End Cap



EC-11 EC-06  
 EC-10 EC-14

AL-6061 ROTOR  
 Smooth Spinning

## Chain Adjuster



CA-01 CA-03 CA-05

## Bottle Bolt



TN-01

## Equipment



Precision CNC bending Machine



Dynamic and Fatigue Testing System

Gemini Bicycle Inc. is an ODM/OEM and aims to serve our customer by providing the highest quality and full service of customization.





# SHENG CHUAN INTERNATIONAL CO., LTD.

Tel: +886-4-7635482 Fax: +886-4-7632455

E-mail: scpag@ms49.hinet.net

http://www.shengchuan.com.tw



SC-C51  
Φ28.6, Φ29.8, Φ31.8, Φ34.9 mm  
Material: Aluminum 7075



SC-C52  
Φ28.6, Φ29.8, Φ31.8, Φ34.9 mm  
Material: Aluminum



SC-C53  
Φ28.6, Φ29.8, Φ31.8, Φ34.9 mm  
Material: Aluminum



SC-C55  
Φ28.6, Φ29.8, Φ31.8, Φ34.9 mm  
Material: Aluminum



SC-C56  
Φ25.4+Φ28.6, Φ27.2+Φ31.8,  
Φ31.8+Φ34.9 (Aluminum)



SC-C57  
Φ27.2+Φ31.8, Φ31.8+Φ34.9  
Material: Aluminum



SC-DS01  
Disc Brake Drain Screw



SC-V16  
Valve Cap



SC-WH01  
Bicycle Wire Holder



SC-U24A  
Unicycle Bearing Housing  
Material: Aluminum



SC-U22A  
Unicycle Bearing Housing  
Material: Aluminum



SC-U23S  
Unicycle Bearing Housing  
Material: Steel



SC-UF01  
Unicycle Frame  
+ Bearing Housing



SC-UF02  
Unicycle Frame  
+ Bearing Housing



SC-DC01  
Derailleur Cage (Shimano)  
11-16T



SC-DC02  
Derailleur Cage (Shimano)  
11-16T



SC-100061-1  
Φ34, Φ37 x 100L  
Material: Steel, Aluminum, Cr-Mo



SC-P100018  
Diam: Φ35, Φ38 mm  
Material: Steel, Aluminum, Cr-Mo



SC-P106024  
Steel: Φ37 mm  
Aluminum: Φ37, Φ49 mm



SC-P106018  
Steel: Φ38 mm  
Aluminum: Φ38, Φ50 mm



SC-P3817  
Diam: Φ38 mm  
Material: Aluminum



SC-P3816  
Diam: Φ38 mm  
Material: Aluminum



SC-P5003  
Diam: Φ50 mm  
Material: Aluminum



SC-C06  
Φ28.6, Φ29.8, Φ31.8, Φ34.9 mm  
Material: Aluminum



SC-C07  
Φ22.2, Φ25.4, Φ28.6,  
Φ29.8, Φ31.8, Φ34.9 mm



SC-C19  
Φ28.6, Φ31.8, Φ34.9 mm  
Material: Aluminum



SC-C21  
Φ25.4, Φ28.6, Φ31.8, Φ34.9 mm  
Material: Aluminum



SC-C24  
Φ25.4, Φ28.6, Φ29.8  
Φ31.8, Φ34.9 mm (Aluminum)



SC-C29  
Φ28.6, Φ31.8, Φ34.9 mm  
Material: Aluminum



SC-C37  
Φ25.4, Φ28.6, Φ31.8, Φ34.9 mm  
Material: Aluminum



SC-C39  
Φ31.8, Φ34.9 mm  
Material: Aluminum



SC-C14  
Φ31.8, Φ34.9 mm  
Material: Aluminum



SC-C35  
Φ31.8, Φ34.9 mm  
Material: Aluminum



SC-STH02  
Diam: Φ28.6, mm  
High: 100, 117 mm



SC-STH05  
Diam: Φ28.6, mm  
High: 100, 117 mm



SC-BE06  
Diam: Φ22.2 mm  
Material: Aluminum



SC-BE07  
Diam: Φ22.2 mm  
Material: Aluminum



SC-BE09  
Diam: Φ22.2 mm  
Material: Aluminum



SC-P100003  
Diam: Φ34, Φ38 mm  
Material: Steel, Aluminum, Cr-Mo



SC-P100005  
Diam: Φ37 mm  
Material: Steel



SC-P100009  
Diam: Φ31, Φ34, Φ37 mm  
Material: Steel, Aluminum, Cr-Mo



SC-P100011  
Diam: Φ34, Φ37 mm  
Material: Steel, Aluminum, Cr-Mo



SC-P100016  
Steel: Φ38 mm  
Aluminum: Φ38, Φ50 mm



SC-P100024  
Diam: Φ31, Φ34, Φ37 mm  
Material: Steel, Aluminum, Cr-Mo



SC-P100051  
Diam: Φ34, Φ37 mm  
Material: Steel, Aluminum, Cr-Mo



SC-P100063  
Diam: Φ38 mm  
Material: Nylon and Cr-Mo



SC-P109019  
Steel: Φ38 mm  
Aluminum: Φ38, Φ50 mm



SC-P106020  
Diam: Φ37 mm  
Material: Steel



SC-P106021  
Steel: Φ38 mm  
Aluminum: Φ38, Φ50 mm



SC-P106029  
Steel: Φ38 mm  
Aluminum: Φ38, Φ50 mm



SC-P106034  
Diam: Φ50 mm  
Material: Aluminum



SC-P2510603  
Diam: Φ25, Φ38 mm  
Material: Aluminum



SC-T2  
Forged Φ25.4 x 60/80L



SC-ST18



SC-ST19



SC-L15  
Applicable Size: 15, 19 mm  
Material: Steel



SC-V02  
Valve Cap



SC-AS01  
Bicycle Compression Damping  
Adjustment Screws



SC-SA900S



SC-AL03  
Spacer



SC-CB01  
M8x0.75x6.5 / 8.5mm



SC-SU04  
OD: Φ16-20



SC-SU10  
OD: Φ22-26



SC-7517-3  
11T



SC-STT1



SC-FS01 SC-FS02  
3/8"x26 / M14x1.0mm

10/14 Adapter



**FA3201**  
Dim :  $\varnothing 32 \times 102L$   
Material : Steel



**FA3202**  
Dim :  $\varnothing 32 \times 102L$   
Material : Steel



**FA3401**  
Dim :  $\varnothing 34 \times 102L$   
Material : AL6061  
AL7075  
Cr-Mo



**FA3403**  
Dim :  $\varnothing 34 \times 102L$   
Material : AL6061  
AL7075  
Cr-Mo



**FA3405**  
Dim :  $\varnothing 34 \times 102L$   
Material : AL6061  
AL7075  
Cr-Mo



**FA3402**  
Dim :  $\varnothing 34 \times 102L$   
Material : AL6061  
AL7075  
Cr-Mo



**FA3401**  
Dim :  $\varnothing 34 \times 102L$   
Material : AL6061  
AL7075  
Cr-Mo



**FA3409**  
Dim :  $\varnothing 34 \times 102L$   
Material : AL6061  
AL7075  
Cr-Mo



**FA3410**  
Dim :  $\varnothing 34 \times 95L$   
Material : Cr-Mo



**FA3420**  
Dim :  $\varnothing 34 \times 102L$   
Material : AL6061  
Cr-Mo



**FA3418**  
Dim :  $\varnothing 34 \times 102L$   
Material : Cr-Mo  
Steel



**FA3601**  
Dim :  $\varnothing 34 \times 102L$   
Material : AL6061  
AL7075  
Cr-Mo



**FA3602**  
Dim :  $\varnothing 36 \times 102L$   
Material : AL6061  
AL7075  
Cr-Mo



**FA3701**  
Dim :  $\varnothing 37 \times 102L$   
Material : AL7075



**FA3702**  
Dim :  $\varnothing 37 \times 110L$   
Material : AL6061  
AL7075  
Cr-Mo



**FA3703**  
Dim :  $\varnothing 37 \times 110L$   
Material : Cr-Mo  
Steel



**FA3705**  
Dim :  $\varnothing 37 \times 110L$   
Material : AL6061  
AL7075  
Cr-Mo



**FA3801**  
Dim :  $\varnothing 38 \times 110L$   
Material : AL6061  
AL7075  
Cr-Mo



**FA3802**  
Dim :  $\varnothing 38 \times 110L$   
Material : AL6061  
AL7075



**FA3803**  
Dim :  $\varnothing 38 \times 110L$   
Material : AL7075+Cr-Mo



**FA3805**  
Dim :  $\varnothing 38 \times 110L$   
Material : AL6061  
Cr-Mo



**FA3807**  
Dim :  $\varnothing 38 \times 110L$   
Material : AL6061  
AL7075



**FA3810**  
Dim :  $\varnothing 38 \times 102L$   
Material : AL6061  
AL7075  
Cr-Mo



**FA3813**  
Dim :  $\varnothing 38 \times 110L$   
Material : AL6061  
AL7075  
Cr-Mo



**FA3814**  
Dim :  $\varnothing 38 \times 110L$   
Material : AL6061  
AL7075  
Cr-Mo



**FA3816**  
Dim :  $\varnothing 38 \times 110L$   
Material : AL6061



**FA3889**  
Dim :  $\varnothing 38 \times 110L$   
Material : AL7075+Cr-Mo



**FA3891**  
Dim :  $\varnothing 38 \times 110L$   
Material : Cr-Mo



**FA3892**  
Dim :  $\varnothing 38 \times 110L$   
Material : AL6061  
AL7075  
Cr-Mo



**FA3893**  
Dim :  $\varnothing 38 \times 110L$   
Material : AL6061



**FA4001**  
Dim :  $\varnothing 40 \times 109L$   
Material : AL7075+PC Outer



**FA5001**  
Dim :  $\varnothing 50 \times 110L$   
Material : AL6061



**FA5002**  
Dim :  $\varnothing 50 \times 110L$   
Material : AL6061



**FA5003**  
Dim :  $\varnothing 50 \times 110L$   
Material : Steel



**FA5015**  
Dim :  $\varnothing 50 \times 110L$   
Material : AL6061



**HOT**



# Taiwan Bicycle Product Info – Available Any Time, Any Place



Taiwan Bicycle Source, the global bicycle industry's most essential purchasing guide is available for iPhones via an app. Thanks to its detailed and comprehensive information, user-friendly interface, and proven marketing effectiveness, TBS has become the most professional, practical, and complete purchasing guide for the world's cycle industry.



**輪彥國際有限公司**  
**WHEEL GIANT INC.**

**軟實力傳媒有限公司**  
**Soft Power Media Co., Ltd.**

No. 193, Tzu-Chiang Rd., Changhua 50095, Changhua, Taiwan  
Tel: 886-4-7350500, 7360794~5 / Fax: 886-4-7357860  
rep@mail.wheelgiant.com.tw / www.bikenews.online

Shanghai 86-512-57515789 / Ningbo 86-574-88210669  
Tianjin 86-22-28137963 / Shenzhen 86-755-81789589