



車輪組

Wheel Parts



WHEEL PARTS ADVERTISERS



C01 Tires/Inner Tubes

Chalin Co., Ltd. 捷林	421
Cheng Shin Rubber Industry Co., Ltd. 正新	418-419
Gumonder Industrial Co., Ltd. 固滿德	422-423
Hwa Fong Rubber Ind. Co., Ltd. 華豐橡膠	424-427
Innova Rubber Co., Ltd. 伊諾華	428-429
Kenda Rubber Ind. Co., Ltd. 建大	430-433
Otrajet Inc. 歐特捷	434-435



Overseas Manufacturers

Cheng Shin Rubber (Xiamen) Ind., Ltd. 正新-廈門	420
---	-----



Brand Companies

Mitroc Fortune Co., Ltd. 晉而	437
Swechen Cycle Ind. Co., Ltd. / Taiwan Bicycle Group Inc. 瑞誠 / 凱殿	436



C02 Rims/Pins

Alex Global Technology Inc. 亞獵士	440-441
A-Pro Tech Co., Ltd. 野寶	438
A-Rim Ent. Co., Ltd. 雅輪	439
Century Metals Co., Ltd. 聖喬	474
Gin Ter Industry Co., Ltd. 金特	445
Her Jiunn Cheng Enterprise Co., Ltd. 和駿成	450-451
Jalco Industry Co., Ltd. 展輪	442-444

Jetset/Hsin Chuan Ind. Co., Ltd. 鑫權	446-449
Jogon Industries Co., Ltd. 久廣	472-473
Ming Chuan Corp. 茗駿	475
Pegasus Metal Co., Ltd. 傑普助	476
Pin Yi Guan Ind. Co., Ltd. 品亦冠	457
Rui Jing Ind. Co., Ltd. 觀璟	477
Saint Jump Enterprise 昇展	463
Sheang Lih Cycle Industry Co., Ltd. 享勵	458-462
Startrace Plastics Industry Co., Ltd. 鑠兆	466
Teny Rim Ent. Co., Ltd. 田霖	464-465
Yuh Shiuann Industries Co., Ltd. 玉鉉	467



Overseas Manufacturers

Kunshan Giant Light Metal Technology Co., Ltd. 捷安特輕合金	468
Shunde - Her Jiunn Cheng (Sd-Hjc) 和駿成-順德廠	452-454
Sprint Composite Technology Ltd. 司浦特	469
Weinmann Metal Products (Huizhou) Co., Ltd. 威盟-惠州	471
Wu Xi Her Jiunn Cheng Cycle Co., Ltd. 無錫和駿成	455-456



Brand Companies

Top Venturer International Limited 大越傑樂	470
---	-----



C03 Spokes/Nipples

Chun Nan Jin-Ji Technical Co., Ltd. 中南金記	1177
Hsing Ta Ind Co., Ltd. 信大	493
Sha-Dar Accessories Co., Ltd. 協達	494-495
Shuhn Lih Enterprise Co., Ltd. 順立	1176

TREAD SKIN DESIGN

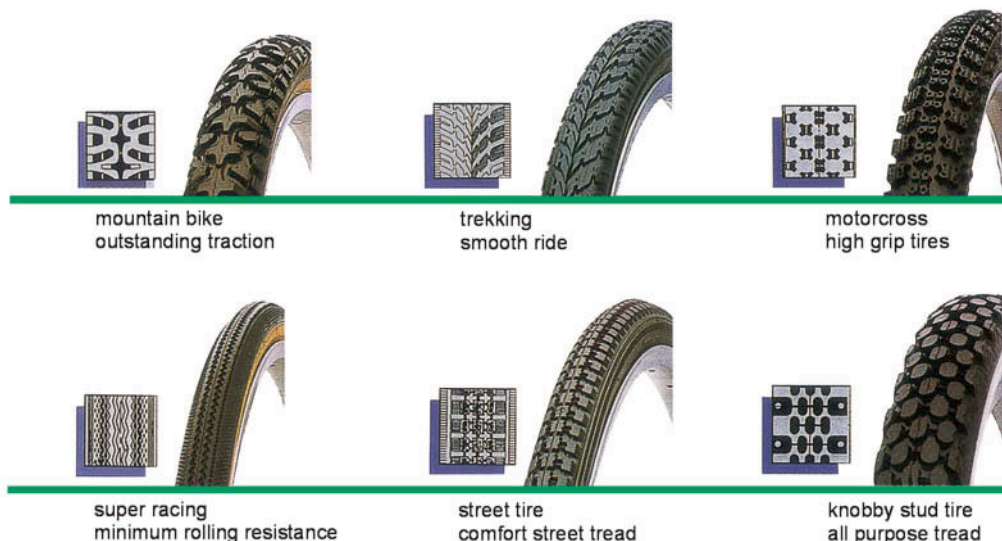

mountain bike
outstanding traction

trekking
smooth ride

motorcross
high grip tires

super racing
minimum rolling resistance

street tire
comfort street tread

knobby stud tire
all purpose tread

Six Union Machinery Ent. Co., Ltd. 六合.....496



C04 Hubs

Assess Ind. Co., Ltd. 雅瑟斯.....	498-499
Bitex Industrial Co., Ltd. 旺輪.....	500
Chin Haur Ind. Co., Ltd. 清豪.....	501
Chosen Co., Ltd. 喬紳.....	502-506
Formula Engineering Inc. 鑫元鴻.....	507
Jinn Yeh (Amoeba) Industrial Co., Ltd. 競業.....	508
Joy Industrial Co., Ltd. 久裕.....	509
Kun Teng Ind. Co., Ltd. 崑藤.....	510-517
Nan Hai Industrial Co., Ltd. 南海.....	518-520
Neco Technology Industry Co., Ltd. 誌慶.....	521
Powerway Industrial Co., Ltd. 東昕.....	529
Samagaga SAMAGAGA.....	522-523
Taiwan Chengfeng Precision Technology Co., Ltd. 誠鋒.....	524-525
Yu Hub Industrial Co., Ltd. 昱泓.....	526-528
Yuan Hong Bicycle Parts Co., Ltd. 遠鋸.....	530



Brand Companies

Grupo Weilico Co., Ltd. 微立各.....531



C06 Valves

Rim Master Industrial Co., Ltd. 立翰.....	532
Y. T. Chen Enterprise Co., Ltd. 永墩.....	533



C07 Plastic Wheels

Chin Chang Plastic Ind. Co., Ltd. 志昌.....	534-535
Chun Shing Ent. Co., Ltd. 春昇.....	536
Grand Harvest Co., Ltd. 大禾.....	537
Lead Since Industry Co., Ltd. 立欣.....	538
Ri Fei Teng Co., Ltd. 日飛騰.....	539



C08 Wheel Set

Achimay Enterprise Co., Ltd. 艾奇美.....	480
Adk Technology Limited 勝捷.....	478-479
Bev Int'l Corp. 精創.....	481
Hubsmith Co., Ltd. 金聯富.....	482
Irwin Co., Ltd. 炯麟.....	483
Joy Industrial Co., Ltd. 久裕.....	484
Kashima Bike International Co., Ltd. 鹿島.....	485
Speeforward Industrial Co., Ltd. 晟禹.....	486
Taiwan Chengfeng Precision Technology Co., Ltd. 誠鋒.....	487
Tai-World-Mfg. Co., Ltd. 景福.....	488
Think Change Composite 信振.....	489



Brand Companies

Emp Inc. 瀚博.....	490-491
Sporza International Co., Ltd. 海飛輪.....	492

LINERS

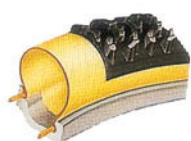

kevlar bead



kevlar belted



kevlar wall



dual compound tread design

VALVES



Schrader
(American type)



Dunlop/Woods
(English type)



Presta
(French type)

MAXXIS®

TIRES



PHOTOS: UNITEDHEALTHCARE PRO CYCLING TEAM

**STRIVE FOR SPEED, SAFTY
NO COMPORMISE**

RELIX / RACING

700X23C 700X25C



- Enhanced traction under wet condition
- Cornering grip increases 20%
- New LRR compound elevate wear capability for 40%



ASSEGAI

as·se·gai > 'asə, gī/

noun

1. a slender, iron-tipped, hardwood spear used chiefly by southern African peoples.



- 27.5x2.5 and 29x2.5
- Wide Trail casing optimized for 30-35mm rims
- 3C MaxxGrip rubber compound for unparalleled traction
- Dual-ply downhill construction
- Tubeless compatible



NEW FOR 2018

South African Greg Minnaar is the winningest racer in World Cup Downhill history. Greg designed the Assegai in conjunction with Maxxis to be a reflection of his well-rounded skillset. The tall knobs punch through dust and loam to find traction, but also offer support and confidence on wet roots and rocks.

The Maxxis Assegai is built to go fast everywhere.

MAXXIS[®]
TIRES



CST[®]

2017 XC OVERALL CHAMPION
YANA BELOMOINA
CST - AMERICAN EAGLE - MTB TEAM



JACK RABBIT II

- TRIPLE COMPOUND
- HIGH SPEED
- HIGH OFF-ROAD GRIP
- HIGH PERFORMANCE



E-BIKE

CL-Be001

12.5X2.25
14X2.125
16X2.125
18X2.125
20X2.125
22X2.125



E-BIKE

CL-B1321

12.5X2.25
14X2.125
16X2.125
18X2.125
20X2.125
22X2.125



TREKKING

CL-B015

16X1.75
18X1.75
20X1.75
20X1.95
22X1.75
24X1.95



TREKKING

CL-B009

24X1.75
26X1.75
700X28C
700X32C
700X35C
700X38C



TREKKING

CL-B030

24 x 1.75
20. x 1.95
24. x 1.95
26. x 1.95
27.5. x 1.95
27.5. x 2.10
24. x 2.10
26. x 2.10
29. x 2.10
24. x 2.125
26. x 2.125
29. x 2.125



FAT BIKE

CL-B034

20X4.0
24X4.0
26X4.0



MTB

CL-B007

12.5x1.75x2.25
14x1.75
16x1.72(1.90)
20X1.75
20X1.95
20X2.125
24X1.75
24X1.95
26X1.75
26X1.95

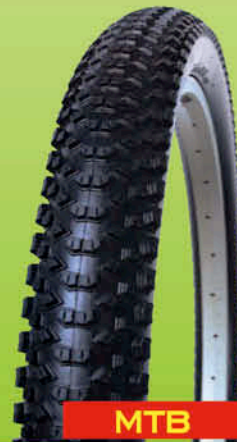

MTB

CL-B034

26X2.35
29X2.10



MTB

CL-B034

12X2.4
14X2.4
16X2.4

CHALIN

Professional Bicycle Tyre

CHALIN CO.,LTD

捷林有限公司

No.15, Aly. 6, Ln. 98,

Zhongzheng E. Rd., Dacun Township

Changhua County 515, Taiwan

彰化縣大村鄉中正東路98巷6弄15號

TEL : +886-4-8527-000

FAX : +886-4-8521-792

MOB : +886-972-297-970

www.chalintyre.com

sales1@chalintyre.com

27.5"



G707

27.5X1.5
26X1.5

G904

27.5X1.95
26X1.75
700X38C

G907

27.5X1.95
26X1.95



FAT BIKE

G810

26X4.0



E-BIKE

G101

16X2.125 20X2.125
20X1.95 24X1.95



G102

16X3



G103

14X2.5 18X2.125
16X2.5 18X2.5
16X3 22X1.95



ROAD

G501

20X1
20X1¹/₈
20X1.35



G502

700X20C 700X23C
700X25C 700X25C
700X28C 700X28C



G803

12¹/₂X2¹/₄
16X2.125
20X2.125



G806S

20X2.25



G903

16X1.75
20X1.75



G906

12¹/₂X2¹/₄



G813

12X2.5



CITY/TREKKING

G701

12X2.0 24X1.5 700X35C
14X1.5 24X1.95
14X2.0 26X1.5
16X1.5 26X1.75
16X1.95 26X1.95
16X2.0 700X32C
18X1.25 700X35C
18X2.0 700X38C
20X1.35 700X42C
20X1.5 700X45C
20X1.95



G708

DARK SIMMON
G804

 27.5X2.1 26X1.95
 29X2.25 26X2.1

G808

 27.5X2.25
 26X1.95

G812

 27.5X2.25
 27.5X3.0
 29X2.25

BMX
G601

20X1.75

G605

 16X1.75
 20X1.75

G607

 20X1.95
 20X2.25

G633

20X2.4

603

 16X2.2 20X2.2
 18X2.2 20X2.35

604

 16X2.3 20X2.3
 18X2.3 22X2.3

617

 20X2.25
 700X32C

G805

26X1.75

G901

 12 1/2X1.75X2 1/4
 16X1.75
 24X1.75
 26X1.75

G902

 24X13/8
 26X13/8

MTB
G801

 16X1.75
 24X1.95
 26X1.95

G802

 16X1.95 24X1.75
 20X1.75 24X2.1
 20X1.95 26X1.75
 20X2.125 26X2.1

G807

26X2.35

固滿德工業股份有限公司
Gumonder Industrial Corporation LTD.

 No.3-8, Ji Lung Hsiang, Ho Ping Li, Jyi Jyi Town, Nan Tou Hsien, Taiwan
 TEL/ +886-49-2762306, +886-49-2760187 FAX/ +886-49-2762889
 E-MAIL: gmd100@ms41.hinet.net; service@gmd-tire.com.tw
 http://www.gmd-tire.com.tw

ISO 9001



DURO
Since 1945
ISO 9001 CERTIFICATE

WWW.DURO.COM.TW
TEL: 886-2-25319833
FAX: 886-2-23221630
E-mail: duroexp2@duro.com.tw

HFR
HWA FONG RUBBER

HWA FONG RUBBER Ind. Co., Ltd.
華豐橡膠工業股份有限公司



Model DB-7072
CHARGER
SIZE: 700x40C(42-622) •



Model DB-7075
CHARGER EXC
SIZE: 28x1.75(47-622) •



Model DB-7053
EASY RIDE
SIZE: 24x2.125(57-507) 26x2.125(57-559)
26x1.75(47-559) 27.5x1.75(47-584)
28x2.00(50-622) 28x2.35(60-622)
700x32C 700x35C(37-622) •
700x38C(40-522)



Model DB-1046
BERM MASTER
SIZE: 20x2.10(56-406) 20x2.35(60-406)
24x2.30 24x2.35
26x1.95(47-559) 26x2.10(54-559)
26x2.25 26x2.30
26x2.35(60-559) 26x2.55(65-559)
• 27.5x2.40(60-584) 29x2.25(57-622)



Model DB-1001A
GREMLIN
SIZE: 20x1.75(47-406) 24x1.75(47-507)
24x1.95(54-559) 26x2.10(54-559)
26x2.25(57-584) •
29x2.20(56-622)



Model DB-1072A
MINER
SIZE: 27.5x3.00(76-584) •
27.5x3.25(82-584)
29x3.00(76-622)
29x3.25(82-622)



Model DB-1075
SWITCH
SIZE: 26x2.50(63-559)
27.5x2.35(60-584) •
29x2.35(60-622) •



Model DB-1077
INFIDEL
SIZE: 27.5x2.25(57-584) •
27.5x2.35(60-584) •
29x2.35(60-622) •



Model DB-1078
CYPHER
SIZE: 27.5x2.10(54-584) •
27.5x2.35(60-584) •
27.5x2.80(70-584) •
29x2.10(54-622)
700x40C(42-622)



Model DB-1081
CHONGO
SIZE: 27.5x2.40(60-584) •



Model DB-1082
TEMPTER
SIZE: 27.5x2.40(60-584) •



Model DB-9040

BIG D

SIZE:26x4.00(100-559)



Model DB-9041

FLEETWOOD

SIZE:24x4.00(100-507)
26x4.00(100-559)



Model DB-7043

STINGER

SIZE:20x1 1/8(28-541) 26x1.25(32-559)
650x23C(23-571) 650x26C(26-571)
700x23C(23-622) 700x25C(25-622)
700x28C(28-622) 700x35C(37-622)



Model DB-7047

HYPERSONIC

SIZE:20x1.35(35-406) 700x20C(20-622)
700x23C(23-622) 700x25C(25-622)
700x28C(28-622)

**DUAL
COMPOUND**



NEW

Model DB-7048

DORADO

SIZE:700x23C(23-622)
700x25C(25-622)
700x28C(28-622)



Model DB-1003

TRITON

SIZE:26x2.00(54-559)
26x2.20(56-559)
27.5x2.20(56-584)
29x2.20(56-622)



Model HF-878

SPITFIRE

SIZE:14x1.75(47-254) 16x1.75(47-305)
20x1.75(47-406) 22x1.75(47-456)
24x1.75(47-507) 24x2.00(54-507)
26x1.50(40-559) 26x1.75(47-559)
26x1.90(50-559) 26x1.95(54-559)
26x2.00(54-559) 28x1.75(47-622)
700x38C(40-622) 700x40C(42-622)



**Tubeless
TLR
Ready**

NEW

Model DB-1080

CRUX

SIZE:**27.5x3.00(76-584)** •
27.5x3.25(82-584)
29x3.00(76-622)
29x3.25(82-622)



Model DB-1006

RAZORBACK

SIZE:24x2.50(64-507) 24x3.00(76-507)
26x2.10(56-559) 26x2.35(60-559)
26x2.50(64-559) 26x2.60(66-559)
26x3.00(76-559)



Model HF-822

DIAMOND GRIP

SIZE:12 1/2x2 1/4(62-203) 14x1 3/8x1 5/8(44-288)
16x1.75(47-305) 16x2.00(54-305)
20x1.75(47-406) 20x2.00(54-406)
20x2.125(54-406) 24x1.75(47-507)
24x1.95(54-507) 24x2.00(54-507)
26x1.75(47-559) 26x1.95(54-559)
26x2.00(54-559) 700x35C(37-622)
700x38C(40-622)



Model HF-880

ELLIE MAE CX

SIZE:26x1.95(52-559)
26x2.00(54-559)
700x35C(37-622)



Model DB-1021

MUCKMEISTER

SIZE:24x2.30(58-507)
26x1.75(47-559)
26x2.30(58-559)
29x2.35(60-622) •



Model DB-7070

FIXIE POPS

SIZE:700x24C(24-622)



Model DB-7034

SIERRA

SIZE:16x1.50(37-305) 22x1.95(50-456)
26x1.50(37-559) 26x1.75(47-559)
28x1.75(47-622) 700x35C(37-622) ●



Model DB-7035

SEVILLA

SIZE:26x1.5(47-559)
700x35C(37-622) ●



Model DB-7042

ENDURANCE

SIZE:16x2.125(57-305) 16x2.50(64-305)
18x2.125(57-335) 18x2.50(64-335)
22x1.75(47-456) 26x1.50(37-559)
26x1.75(47-559) 28x1.75(47-622)
700x38C(40-622)



Model DB-7044

CORDOBA

SIZE:20x1.75(47-406) 24x1.75(47-507)
24x1.90(50-507) 26x1.75(47-559)
26x1.90(50-559) 28x1.75(47-622)
700x35C(37-622) ● 700x38C(40-622)
700x40C(42-622)



NEW

Model DB-5060

EL JEFE

SIZE:18x2.20
20x2.10
20x2.40
24x2.20



Model DB-5031

FANTASY

SIZE:18x1.95(52-355)
20x1.95(47-406)H.P.
20x2.10(54-406)H.P.



Model DB-1012

BEACH BUM

SIZE:20x2.125(57-406)
24x2.125(57-507)
26x2.125(57-559)
26x3.00(70-559)



Model DB-1076

HUP!

SIZE:700x32C(32-622)



Model HF-884

X-PERFORMER

SIZE:16x1.75(47-305)
20x1.75(47-406)
20x1.95(50-406)



TruShine Reflective Tire

Available for all line.

- Features:
- 1.High stiffness carcass effectively reduce rolling resistance and increasing riding speed.
 - 2.Special reflective materials, Anti-cut and Anti-puncture tire sidewall. Good safety when ride in the dark.
 - 3.Foldable tire, easy carry.



Foldable Bead Tire

Available for all line.

臺灣自行車登山王挑戰
TAIWAN KOM
CHALLENGE

PRESENTED BY  **DURO**



 **DURO**

Manufacturer of Tires & Tubes

SINCE 1945

WWW.DURO.COM.TW

E-BIKE



E-BIKE 50

For fast e-bikes, tires with ECE-R 75 certification

*The maximum Speed is 50km/h.

*The maximum load is 150kgs for one E-bike.

E-BIKE50 tires coming soon!!!

NEW



E-BIKE

*The maximum Speed is 25km/h.

*The maximum load is 150kgs for one E-bike.

Cross Fit

Flint

Delta Force



BMX



20x2.25 **NEW**
20x2.4 **NEW**

IB-3009



12 1/2x2 1/4
16x1.75
16x2.10
18x2.10
20x1.75
20x2.0
20x2.20
20x2.30
20x2.4
26x2.0
26x2.20

IA-2128



20x2.0
20x2.25

IA-2248



20x1.75
20x2.0

IA-2502

MTB



24x2.35 **NEW**
26x2.0
26x2.35
27.5x2.35 **NEW**

IA-2530



26x2.0
26x2.35

IA-2545



20x1.95
24x1.95
26x1.75
26x2.0
26x2.25 **NEW**
27.5x1.95
27.5x2.10
29x2.10
29x2.25

IA-2549



14x2.10 **NEW**
16x2.10 **NEW**
18x2.125
20x2.0
24x2.0 **NEW**
26x2.10
27.5x2.10
29x2.10

IA-2569

FAT



20x3.0
24x3.0

IA-2018



27.5x2.8
29x3.0

IA-2569



20x4.0 **NEW**
24x4.0 **NEW**
26x4.0
27.5x3.0

LV-1003



26x4.0
26x4.8

LV-1008





Visit us on the web at:
KendaTire.com



facebook KendaBicycle

KENDA

SINCE 1962 TIRES

BMX CITY/TREKKING

KWICK SERIES



K1152
 700x45C
 700x40C
 700x35C
 650Bx45C

FLINTRIDGE



K1216
 700x50C 27.5x2.20
 700x45C 27.5x2.00
 700x42C 27.5x1.75
 700x40C 26x2.20
 700x38C 26x2.00
 700x35C 26x1.75

KWICK DRUMLIN



K1175
 700x33C

CHOLLA



K1067
 700x38C 26x1.75
 700x35C 26x1.50
 700x32C
 700x28C
 700x25C
 27x1-1/4

KWICK TENDRIL



K1068
 700x45C 26x1.50
 700x40C
 700x38C
 700x35C
 700x32C
 26x1.75

KWICK BITUMEN



K1053
 700x38C 26x1.25 24x1
 700x35C 26x1
 700x32C 25x1
 700x28C 24x1.75
 26x1.75 24x1.50
 26x1.50 24x1-3/8

KWICK TRAX



K1129
 700x42C
 700x40C
 700x38C
 27.5x1.75
 26x1.75

KWICK JOURNEY



K1052
 29x2.20
 29x2.00
 27.5x1.75

KWICK NINEKWICK SEVEN.5

BMX



K1052
 26x2.10
 24x2.10
 20x2.30

KRANIUM



K905
 26x2.50 24x1.95
 26x2.30 24x1.75
 26x2.125 20x2.35
 26x1.95 20x2.125
 24x2.30 20x1.95
 24x2.125 20x1.75

K-RAD



K1040
 20x2.30
 20x2.25
 20x2.10
 20x1.85

KID BLOCK



K1041
 20x2.25

KASSETTE



K1079
 24x1.95 20x1.50
 24x1.75
 24x1.50
 20x1.95
 20x1.75
 20x1.65

KONVERSION



K1054A
 20x1.95
 20x1.75
 20x1.50
 20x1-1/8

KOMPACT RACE



K1131
 20x2.25
 20x2.10

COUPE



K1132
 20x2.35
 20x2.10

ADMIRAL

Visit us on the web at:
KendaTire.com



facebook KendaBicycle

KENDA
 SINCE 1962 **TIRES**

**MOUNTAIN
 ENDURO/ALL-MOUNTAIN**

MOUNTAIN SERIES



27.5

K1201

29x2.60
 29x2.40
 27.5x2.60
 27.5x2.40

HELLKAT



27.5

K1202

27.5x2.40

HELLDIVER



27.5

K1211

29x2.60
 29x2.40
 27.5x2.60
 27.5x2.40

NEVEGAL²



K942

29x2.20
 29x2.00
 26x2.00
 26x1.75

KOZMIK LITE II



27.5

K1150

29x2.20
 27.5x2.35
 27.5x2.10
 26x2.35
 26x2.10

NEVEGAL X



27.5

K1127B

27.5x2.40
 26x2.40

HONEY BADGER DH



27.5

K1127A

29x2.20
 29x2.05
 27.5x2.05

HONEY BADGER XC



27.5

K1127

29x2.20
 29x2.05
 27.5x2.05

HONEY BADGER XC



27.5

K1150

29x2.20
 29x2.05
 27.5x2.20
 27.5x2.05

SABER



K1059

26x2.50
 26x2.35
 26x2.10
 26x1.95

EXCAVATOR



K1151

26x4.80
 26x4.50
 26x4.00

JUGGERNAUT



27.5

K1184

27.5x3.00
 27.5x2.80

HAVOK



27.5

K1080

29x2.35 26x2.50
 29x2.20 26x2.35
 29x2.00 26x2.10
 29x1.80 26x1.95
 27.5x2.10

SLANT SIX



K1083A

700x40C
 700x35C
 700x32C
 24x1.125

HAPPY MEDIUM

Visit us on the web at:
KendaTire.com



facebook KendaBicycle

ROAD/ ENDURANCE

KENDA SINCE 1962 TIRES

ROAD SERIES



K1160X
 700x30C
 700x28C
 700x25C
 700x23C

VALKYRIE



K925
 700X23C
 700X20C
 650X23C

KALIENTE



K1018
 700x30C 22x1.25
 700x25C 20x1.25
 700x23C 20x1-1/8
 650x25C 20x1
 650X23C 18x1.25

KRITERIUM



K1081
 700x28C
 700x25C
 700x23C

KADENCE



K1092
 700x28C
 700x25C
 700x23C

KOUNTACH

ENDURANCE SERIES



K1092
 700x28C
 700x25C
 700x23C

KOUNTACH ENDURANCE



K1018
 700x30C 20x1.25
 700x28C 20x1.00
 700x25C
 700x23C
 650x23C

KRITERIUM ENDURANCE



K1067
 700x38C 26x1.50
 700x35C
 700x32C
 700x28C
 26x1.75

KWICK TENDRIL ENDURANCE

KENDA



2017 TAIWAN EXCELLENCE
SILVER AWARD

IMMORTAL CHOICE



K1160X VALKYRIE



K-ARMOR

K-Armor is a proprietary casing material technology developed by Kenda for superior puncture protection and rolling resistance.



R3C COMPOUND

R3C is Kenda's fastest rubber compound and used exclusively for high end racing tires.

Kenda Taiwan-146, Section 1, Zhōngshān Rd Yuanlin Township, Changhua County 510 Taiwan

TEL: (886) 4-8345171 FAX: (886) 4-8331865



NEXO

AIR-LIGHT SOLID TIRE

@ www.nexotire.com

✉ nexo@otrajjet.com

☎ +886-4-23599119

📘 NEXO Taiwan

Inflation-free
Burst-proof
Eco-friendly
Zero Maintenance



T-Bolt. 獨家專利安全扣件
Preventing rim-out and tire twisted.

歐特捷獨家專利安全扣件:T-Bolt, 將NEXO車胎穩定於輪圈中心處, 防止車胎脫框、扭曲。

T-Bolt, Otrajjet's exclusive patented safety device, keeps NEXO tires in the center of rims, preventing rim-out and tire twisted.



BIKE TIRE	16"	16"	18"	20"	20"	24"
Inch	16" x 1-3/8	16" x 1.5	18" x 1.5	20" x 1.5	20" x 1-1/8	24" x 1-3/8
Tire ETRTO	37-349	40-305	40-355	40-406	28-451	32-540
French	--	--	--	--	--	--
Suitable Rim width (interior)	17-20 mm	17-20 mm	17-20 mm	17-20 mm	12-16 mm	17-20 mm
T-Bolt	S	L	S	S	SS	S

Color ● ● ● ● ● ● ● ● ● ● ● ● ● ● ● ● ● ●



for Commuter



for Ladies



for Sharing bike



for Trainer

NEXELL® is innovated by OTRAJET Inc. through integration of more than three macromolecular materials via Cross Linking into the primary material of light-weight, solid NEXO bike tires, offering a solution to cracking due to reactions between traditional pneumatic tires and active oxygen (O3, ozone) as well as meet users' expectation for bike tires with conditions such as eco-friendliness, weather-proof, wear-proof and skid-proof physical properties.

NEXO主要成份為NEXELL®, 由歐特捷實業股份有限公司(OTRAJET Inc.)所開發之複合式高分子材料, 透過化學鍵(Cross Linking)與一體成型發泡技術所製成的NEXO自行車胎, 符合JIS實心車胎5,000 Km耐磨耗測試、德國PAHs產品安全規範, 以及歐盟RoHs環保指令; 重量上, 較傳統實心車胎減輕約40%重量, 同時解決傳統氣胎與空氣中活性氧(O3, 臭氧)反應後龜裂的問題。符合使用者對於自行車胎需有環保、耐候、耐磨、止滑等物理條件之要求。



Longer abrasion durability
耐磨騎更久

符合日本JIS
5,000 km
耐磨耗測試



Air-light
舒適輕量化

一體成型發泡射出
技術, 較傳統防爆
車胎, 重量減輕40%



Braking performance
良好止滑表現

前後輪均通過ISO
4210:2015煞停測試標準,
可以安全行進於乾地和濕地



Eco-friendly
環保

符合歐盟RoHs
環保指令



Non-toxic
無毒

符合德國PAHs
產品檢測標準



Exclusive patented
安全不脫框

獨家專利T-Bolt安全扣件
防止車胎脫框、扭曲

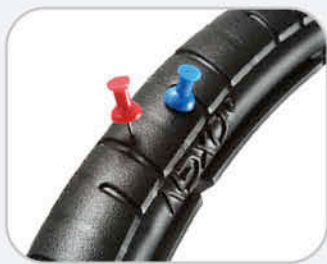

Burst-proof / Inflation-free
Safe and Convenient



Multi-Color Option /
Customization

客製化服務

Customization
now available

量身打造專屬尺寸、
胎色的NEXO車胎。



NEXO Tire website



24"	26"	26"	27"	700x24C	700x35C
24"x1.35	26" x 1.5	26" x 1-3/8	27" x 1-3/8	--	--
32-507	40-559	34-590	35-642	24-622	35-622
--	--	650 x 35A	--	700 x 24C	700 x 35C
17-20 mm	17-20 mm	17-20 mm	17-20 mm	12-16 mm	17-20 mm
S	L	S	S	SS	S

HORNG FORTUNE

MOTORCYCLE AND BICYCLE

TIRES & TUBES

MADE IN VIETNAM

MOTORCYCLE TIRES

							
F-897	F-927	F-923	F-933	F-936	F-888	F-851	F-879
<ul style="list-style-type: none"> • 100/100-17 • 100/100-18 • 110/100-18 	<ul style="list-style-type: none"> • 120/90-10 • 130/90-10 • 130/60-13 	<ul style="list-style-type: none"> • 2.75-17 • 100/80-17 • 120/90-17 	<ul style="list-style-type: none"> • 2.75-18 • 130/90-16 • 110/70-17 	<ul style="list-style-type: none"> • 100/90-18 	<ul style="list-style-type: none"> • 2.75-16 • 80/100-14 • 90/90-18 	<ul style="list-style-type: none"> • 2.25-16 • 2.25-17 • 2.50-16 	<ul style="list-style-type: none"> • 2-1/4-16 • 2-1/2-16 • 2-1/2-17



BICYCLE TIRES

							
F-121	F-118	F-132	F-364	F-268	F-107	F-105	F-203
<ul style="list-style-type: none"> • 20x2.125 	<ul style="list-style-type: none"> • 12-1/2x2-1/4 • 16x1.75 • 20x1.75 	<ul style="list-style-type: none"> • 20x2.125 • 24x2.125 • 26x2.125 	<ul style="list-style-type: none"> • 26x1.95 • 26x2.10 	<ul style="list-style-type: none"> • 26x1.95 • 26x2.10 • 26x2.125 	<ul style="list-style-type: none"> • 20x2.125 • 24x2.125 • 26x2.125 	<ul style="list-style-type: none"> • 16x1-3/8 • 26x1-3/8 • 28x1-1/2 	<ul style="list-style-type: none"> • 20x1-3/8 • 26x1-1/2x1-5/8 • 27x1-1/4

www.horngfortune.com

email: hf@horngfortune.com

More difficult road more can overcome



ISO 9001 (E4)

FORTUNE

TIRES & TUBES



MITROC FORTUNE CO., LTD.

E-MAIL: mitroc@ms4.hinet.net / E-MAIL: mitroc@hcm.vnn.vn



Carbon
ROAD50
R501-C50CL
CLINCHER

E.T.R.T.O.	21-622
Rim Weight	476.9±15g
Rim Depth	50.0mm
Rim Width	26.6mm
Max.Tire Pressure	110.0psi



Carbon
ROAD35
R701-C35CL
CLINCHER

E.T.R.T.O.	24-622
Rim Weight	426.6±15g
Rim Depth	35.0mm
Rim Width	30.0mm
Max.Tire Pressure	75.0psi



Carbon
ROAD40
R602-C40CL
CLINCHER

E.T.R.T.O.	21-622
Rim Weight	440.8±15g
Rim Depth	40mm
Rim Width	26.6mm
Max.Tire Pressure	110 psi



Carbon
ROAD30
R502-C30CL
CLINCHER

E.T.R.T.O.	21-622
Rim Weight	400±15g
Rim Depth	30mm
Rim Width	26.6mm
Max.Tire Pressure	110.0psi



Carbon
XC275
M604-C30HL
HOOKLESS

E.T.R.T.O.	24-584
Rim Weight	352.5±15g
Rim Depth	22.0mm
Rim Width	30.0mm
Max.Tire Pressure	50.0psi



Carbon
GRAVEL275
M203-C31HL
HOOKLESS

E.T.R.T.O.	24-584
Rim Weight	431.1±15g
Rim Depth	31.0mm
Rim Width	31.0mm
Max.Tire Pressure	50.0psi

The background of the advertisement features several bicycle rims. Two rims are prominently displayed at the top, showing the 'A-RIM' branding. Below them, a red diagonal banner contains the company logo and website. At the bottom, a close-up of a welded rim joint is shown, with a small amount of white residue on the seam. The overall aesthetic is professional and technical.

As a professional rim manufacturer, A-RIM marches toward to be a comprehensive service provider and center in rim request, and furthermore expect to promote your cycling life.

With the past decades in production, we own deep R&D and manufacturing base to offer the program options and solutions of spec range , rim design, rim materials, seam joints (pin, sleeve, and welding) and quality to fulfill whatever the cycling condition is.

A-RIM

www.a-rim.com.tw

A welded rim is obedient to carry out great capability through higher pressure resistance on the core of the rim, the seam. A-RIM's welding technology develops the applicable elements to make rims own both the high enhancement and great stability on the pressure resistance.

ALEXRIMS

FOR THE WAY YOU RIDE

WHEEL SETS

ALX845C

USAGE: Road Race

RIM: 700x45mm Deep Carbon for Rim Brake

HUB: Sealed Bearing SHIMANO

SPOKES: 20F/24R Stainless Bladed

WEIGHT: 1560g/Pr

The 845C strikes a balance between straight-line aero performance and nimble handling. Our newly shaped full carbon rim with rounded cross sectional profile is laced to our proprietary ultralight hubs for a wheel set unmatched by any other.

ALX845D

USAGE: Road Race, Gravel, CX

RIM: 700x45mm Deep Carbon for Disc Brake

HUB: Sealed Bearing SHIMANO/SRAM

SPOKES: 24F/24R Stainless Bladed

WEIGHT: 1690g/Pr

For the ultimate in low weight performance Alexrims Wheels offers our full carbon ALX845D Wheelset.

RXD3

USAGE: Road Race

RIM: 700x30mm Deep Alloy for Disc Brake

HUB: Sealed Bearing 8, 9, 10 & 11 spd

SPOKES: 24F/24R Stainless

WEIGHT: 1550g/Pr

A premium competition-worthy alloy disc road wheel set that is equally at home in a race or local club ride.

BOONDOCKS 3

USAGE: Gravel, CX

RIM: 700x30mm Deep Alloy for Disc Brake

HUB: Sealed Bearing 8, 9, 10 & 11 spd

SPOKES: 24F/24R Stainless

WEIGHT: 1714g/Pr

Designed to take you virtually anywhere you want to go, the Boondocks are robust, agile and fast rolling.

亞獵士科技股份有限公司
ALEX GLOBAL TECHNOLOGY INC.
台南市山上區明和里北勢洲21-2號
No.21-2, Beishizhou, Minghe VII.,
Shanshang Dist., Tainan City 743,
Taiwan
電話: +886-6-5782151
傳真: +886-6-5782394
E-MAIL: alexrims@alexrims.com.tw
WEB: www.alexrims.com

益昌鋁製品(太倉)有限公司
XYZ ALUMINIUM PRODUCTS
(TAI CANG) CO., LTD.
益昌鋁製品(太倉)有限公司
No.2 Tai-Pei Road, Yue-Wang District, Sha-Xi Town,
Tai-Cang City, Jiang-Su Province, China
江蘇省太倉市沙溪鎮岳王臺北路2號
電話: +86-512-5345 6636 53458348
傳真: +86-512-5345 8322
E-mail: alextc53456636@163.com

大造熊科技股份有限公司
Bear Pawls, Inc.
台中市大雅區鳳鳴路6-1號
No.6-1, Fengming Rd., Daya Dist.,
Taichung City 428, Taiwan
電話: +886-4-25606996
傳真: +886-4-25606886
E-mail: bearpawls@bearpawls.com.tw
WEB: www.bearpawls.com

大造熊公司
DA CHAO SHONG CO., LTD.
柬埔寨暹羅省巴城區第一號大城巴城經濟特區+ (大造熊公司)
TAI SENG BAVET SPECIAL ECONOMIC ZONE, NATIONAL ROAD, 1,
BAVET CITY, SVAY RIENG PROVINCE, CAMBODIA
DA CHAO SHONG CO., LTD.
電話: 044 712 265
E-mail: dachaoshong@gmail.com

WWW.ALEXRIMS.COM

Taiwan Bicycle Source 2018-2019



BEAR PAWLS

STRAIGHT PULL SERIES FRONT HUB

BRV-001

A svelte, minimalist front hub ideal for climbing and aero wheelsets.



DISC MOUNT	N/A
HOLE COUNT	20
GAUGE	14G
O.L.D.	100mm
AXLE	QR
WEIGHT	60g
BEARING	2

STRAIGHT PULL SERIES REAR HUB

BRV-002

Combines sleek design, low weight and advanced features for the fastest rear wheels.



DISC MOUNT	N/A
HOLE COUNT	24
GAUGE	14G
O.L.D.	130mm
AXLE	QR
CASSETTE	B/E/I
WEIGHT	220g (E)
BEARING	4

STRAIGHT PULL SERIES FRONT HUB

BMB-001

Boost spacing is ideal for Enduro, Plus and Trail applications.



DISC MOUNT	6-Bolt
HOLE COUNT	28
GAUGE	14G
QR-TYPE	15mm
O.L.D.	110mm
WEIGHT	142g
BEARING	2

J-BEND SERIES REAR HUB

BMB-004

Rear spacing and standard XD driver is the perfect Enduro and All Mountain rear hub.



DISC MOUNT	6-Bolt
HOLE COUNT	28/32
GAUGE	14G
QR-TYPE	QR or 12mm
O.L.D.	148mm
AXLE	12x148
CASSETTE	A/D/H/C/G
WEIGHT	280g (H)
BEARING	4

J-BEND SERIES REAR HUB

BEB-004

Robust construction is able to handle the added torque of E-Bike applications.



F/R	R
HOLE COUNT	28/32
GAUGE	14G
QR-TYPE	12mm
O.L.D.	148mm
DERAILLEUR	Shimano/Sram
WEIGHT	417g
BEARING	4

J-BEND SERIES REAR HUB

BFB-004

Extra wide spacing is optimal for Fat Bike applications requiring a wide stance in an efficient system.



DISC MOUNT	6-Bolt
HOLE COUNT	32
GAUGE	14G
QR-TYPE	12mm
O.L.D.	197mm
DERAILLEUR	Shimano/Sram
WEIGHT	407g
BEARING	4



公司名: 大造熊科技股份有限公司
 地址: 428-72台中市大雅區鳳鳴路6-1號
 電話: 04-25606996
 傳真: 04-25606886
 信箱: bearpawls@bearpawls.com.tw

BEAR PAWLS, INC.
 1F, NO.6-1, Fengming Rd., Daya Dist.,
 Taichung City 42872, Taiwan
 TEL: +886-4-25606996
 FAX: +886-4-25606886

WWW.BEARPAWLS.COM





展 輪

JALCO INDUSTRY CO., LTD.

NO. 22, SEC. 1, CHANG YUAN RD., HUA TAN TOWNSHIP,
CHANGHUA COUNTY, TAIWAN

TEL: 886-4-7870767 7870768 FAX: 886-4-7870788

E-mail: peter@jalcorim.com E-mail: price@jalcorim.com

http://www.maddux-wheels.com

More stability of spokes' tension on
wheels due to nipple and rim wall contacted tightly.
Tension and Torque Stability system, called TTS.
US 2013/0169029 A1, Germany DE202012105076U1.

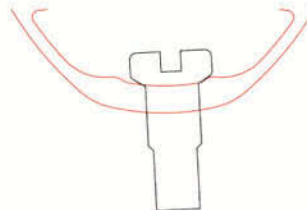
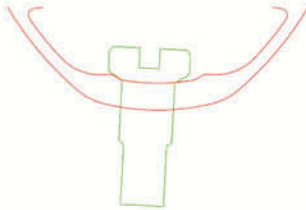

(10) United States
(12) Patent Application Publication
(41) CHEN

(10) Pub. No.: US 2013/0169029 A1
(41) Pub. Date: Jul. 4, 2013

(12) BICYCLE RIM
(71) Applicant: JALCO INDUSTRY CO., LTD.
Changhua (Taiwan) (TW)
(72) Inventor: HAN-FENG CHEN, CHANGHUA
SHIH (TW)
(73) Assignee: JALCO INDUSTRY CO., LTD.
CHANGHUA SHIH (TW)

(21) Appl. No.: 13744073
(22) Filed: Dec. 18, 2012
(30) Foreign Application Priority Data
Dec. 26, 2011 (TW) 100224615

Publication Classification
(51) Int. Cl.⁷: B60B 2/06 (2006.01)
G16C 2/00 (2013.01)
G16C 2/02 (2013.01)
G16C 2/04 (2013.01)

ABSTRACT
A bicycle includes a substantially diamond shaped frame and two support portions respectively formed on two opposite edges of the frame, wherein each support portion comprises a horizontal portion and a vertical portion. The horizontal portion of the support is divided into a first inclined face and a second inclined face. Each inclined face has a series of fins through holes and a series of fins through holes. Each inclined face has a series of fins through holes and a series of fins through holes in the diameter of the bicycle rim, where the fins through holes in the first inclined face are staggered to that in the second inclined face.

(10) Deutsches
Patent- und Markenamt

Gebrauchsmusterschrift

(11) Anmeldenummer: DE 20 2012 105 076 U1 (11) M-Num.: 8608 2106 (2013.01)

(21) Anmeldetag: 27.12.2012
(41) Eröffnungsdatum: 26.09.2013
(22) Beantragungsjahr in Frankfurt: 21.03.2013

(30) Prioritätsanspruch: 26.12.2011 TW (31) Name und Wohnort des Erfinders:
Langhelfer, Axel/Markus, 85671, München, DE

(71) Name und Wohnort des Erfinders:
JALCO INDUSTRY CO., LTD., Changhua, TW

Die folgenden Angaben sind über vom Anmelder angegebenen Unterlagen entnommen.
(30) Bezeichnung: Felgenreifung

(52) Hauptanspruch: Felgenreifung, umfasst eine Felge (10) und eine Nippel von jeweils einem Speichenanschluss (12) auf gegenüberliegenden Seiten (20), die in einem gemeinsamen Nippel und Nippelring (14) angeordnet sind, wobei die Nippel (12) den Nippelring (14) zum Durchdringen der Felge (10) durchdringen und die Nippel (12) die Felge (10) durchdringen und die Nippel (12) die Felge (10) durchdringen und die Nippel (12) die Felge (10) durchdringen.

www.maddux-wheels.com

Road rims

ID : 32
OD: 36.2
H : 18

Available for E-bike

Road rims

ID : 32
OD: 27.8
H : 18

E-bike ; TTS RIM

Road rims

ID : 44
OD: 39.8
H : 19

E-bike ; TTS RIM

Road rims

ID : 28
OD: 23.8
H : 18

E-bike ; TTS RIM

SHL36 (Tubless ready)
Size : 29er 622x32C
27.5" 584x32C
Weight : 590 g (29er) /
560 g (27.5")
Finished : Anod.BK
Joint : Sleeved
Option : Anod., Powder colors
Holes : 28,32

E-SHL32 (Tubless ready)
Size : 29er 622x28C
27.5" 584x28C
Weight : 555 g (29er) /
525 g (27.5")
Finished : Anod.BK
Joint : Sleeved
Option : Anod., Powder colors
Holes : 28,32

E-PHL44 OS (Tubless ready)
Size : 29er 622x40C
Weight : 765 g (29er)
Finished : Anod.BK
Joint : Pinned
Option : Anod., Powder colors
Holes : 28,32

E-PHL28 (Tubless ready)
Size : 29er 622x24C
27.5" 584x24C
Weight : 565 g (29er) /
535 g (27.5")
Finished : Anod.BK
Joint : Pinned
Option : Anod., Powder colors
Holes : 28,32



HL 42 OS (Tubless ready)
Size : 29er 622x38C
27.5" 584x38C
Weight : 610 g (29er) / 580 g (27.5")
Finished : Anod.BK
Joint : Sleeved
Option : Anod., Powder colors
Holes : 28,32



TWHL 28 OS (Tubless ready)
Size : 29er 622x25C
27.5" 584x25C
Weight : 495 g (29er) / 470 g (27.5")
Finished : Anod.BK
Joint : Sleeved
Option : Anod., Powder colors
Holes : 28,32



WHL 26 OS (Tubless ready)
Size : 29er 622x23C
27.5" 584x23C
Weight : 415 g (29er) / 395 g (27.5")
Finished : Anod.BK
Joint : Welded
Option : Anod., Powder colors
Holes : 28,32



PHL 320 OS (Tubless ready)
Size : 29er 622x29C
27.5" 584x29C
Weight : 545 g (29er) / 515 g (27.5")
Finished : Anod.BK
Joint : Pinned
Option : Anod., Powder colors
Holes : 28,32

Road & Cycle-cross



PHL 280 OS (Tubless ready)
Size : 29er 622x25C
27.5" 584x25C
Weight : 495 g (29er) / 470 g (27.5")
Finished : Anod.BK
Joint : Pinned
Option : Anod., Powder colors
Holes : 28,32



WHL 520 OS (Tubless ready)
Size : 29er 622x22C
Weight : 515 g
Finished : Anod.BK
Joint : Welded
Option : Anod., Powder colors
Holes : 32



WHL R 480 V (Tubless ready)
Size : 29er 622x21C
Weight : 480 g
Finished : Anod.BK
Joint : Welded
Option : Anod., Powder colors
Holes : 32



RT 405 (Tubular)
Size : 700C 622
Weight : 405 g
Finished : Anod. BK, CNC
Joint : Welded
Option : Anod., Powder colors
Holes : 28,32

Road & Cycle-cross



TR R 455 D (Tubless ready)
Size : 700C 622x16C
Weight : 445 g
Finished : Anod. BK
Joint : Welded
Option : Anod., Powder colors
Holes : 28,32

Road & Cycle-cross



TR R 455 D OS (Tubless ready)
Size : 700C 622x16C
Weight : 455 g
Finished : Anod. BK
Joint : Welded
Option : Anod., Powder colors
Holes : 28,32
Offset rim

Road & Cycle-cross



TR X 415 OS (Tubless ready)
Size : 700C 622x19C
Weight : 460 g
Finished : Anod. BK
Joint : Welded
Option : Anod., Powder colors
Holes : 28,32
Offset rim

Road & Cycle-cross



TR X 415 (Tubless ready)
Size : 700C 622x16C
Weight : 455 g
Finished : Anod. BK
Joint : Welded
Option : Anod., Powder colors
Holes : 28,32

Road & Cycle-cross

ID : 24
OD: 19
H : 24



SR 240 (Tubuleless ready)
Size : 700C 622x19C
Weight : 440 g
Finished : Anod. BK
Joint : Sleeved
Option : Stainless eyelets
Anod., Powder colors
Holes : 32

Road & Cycle-cross

ID : 26
OD: 21
H : 30



SR 500 (Tubuleless ready)
Size : 700C 622x21C
Weight : 520 g
Finished : Anod. BK
Joint : Sleeved
Option : Anod., Powder colors
Holes : 32

Road & Cycle-cross

ID : 24
OD: 19
H : 30



FR 300 (Tubuleless ready)
Size : 700C 622x19C
Weight : 515 g
Finished : Anod. BK
Joint : Sleeved
Option : Anod., Powder colors
Holes : 28,32

Road & Cycle-cross

ID : 24
OD: 19
H : 30



PPFR 300
Size : 700C 622x19C
Weight : 580 g
Finished : Anod. BK
Joint : Pinned
Option : Anod., Powder colors
Holes : 32

Road & Cycle-cross

ID : 21.5
OD: 16.6
H : 30



DRX 33
Size : 700C 622x17C
Weight : 550 g
Finished : Anod. BK
Joint : Pinned
Option : Anod., Powder colors
Holes : 28,32

Road & Cycle-cross

ID : 21.5
OD: 16.6
H : 24



DRX 24
Size : 700C 622x17C
Weight : 500 g
Finished : Anod. BK
Joint : Pinned
Option : Stainless eyelets
Anod., Powder colors
Holes : 28,32

MTB

ID : 26
OD: 21
H : 18



XCD 18 OS
Size : 29er 622x21C
27.5" 584x21C
26" 559x21C
Weight : 490 g (29er) / 465 g (27.5")
440 g (26")
Finished : Anod.BK
Joint : Pinned
Option : Anod., Powder colors
Holes : 28,32
Offset rim

MTB

ID : 28
OD: 22.6
H : 18



XCD 23
Size : 29er 622x23C
27.5" 584x23C
26" 559x23C
Weight : 570 g (29er) / 540 g (27.5")
510 g (26")
Finished : Anod.BK
Joint : Pinned
Option : Anod., Powder colors
Holes : 28,32

MTB

ID : 24.9
OD: 20
H : 30



PDM 30
Size : 29er 622x20C
27.5" 584x20C
26" 559x20C
Weight : 560 g (29er) / 530 g (27.5")
505 g (26")
Finished : Anod.BK
Joint : Pinned
Option : Anod., Powder colors
Holes : 28,32

MTB

ID : 38
OD: 32.8
H : 18



DD38
Size : 29er 622x33C
27.5" 584x33C
26" 559x33C
Weight : 600 g (29er) / 570 g (27.5")
540 g (26")
Finished : Anod.BK
Joint : Pinned
Option : Anod., Powder colors
Holes : 28,32

MTB

ID : 45.7
OD: 39.7
H : 19



DD45 (Tubuleless ready)
Size : 27.5" 584x40C
Weight : 710 g
Finished : Anod.BK
Joint : Pinned
Option : Anod., Powder colors
Holes : 28,32

Fat rims

ID : 90
OD: 86
H : 21.1



SNOWY 90
Size : 26" 559 x 86C
Weight: 1200 g
Finished: Anod. BK, eyelets
Joint : Welded
Option : Anod., Powder colors
Holes : 32, 36

E-Bike

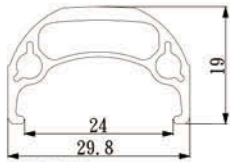

BM30
Pin joint
Size:29"/27.5"(650B)/
24"/20"

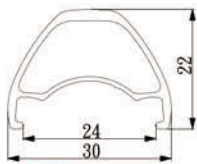

GTD30
Sleeved /Weld joint
Size:29"/27.5"(650B)/24"
for tubeless ready

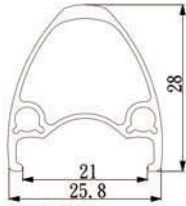

XD28
Pin joint
Size:29"/27.5"(650B)/24"
for tubeless ready

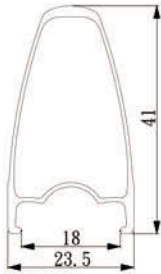

XRD
Weld joint
Size:700c
for tubeless ready

ROAD for tubeless ready

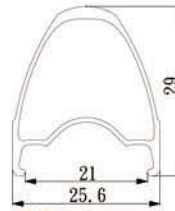

RV29
Sleeved joint
Size:700C/650C

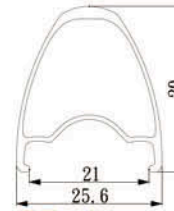

RD29
Sleeved joint
Size:700C/650C

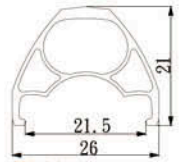

X45
Sleeved joint
Size:700C/650B

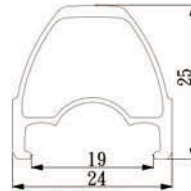

GTM25
Sleeved joint
Size:700C/650C

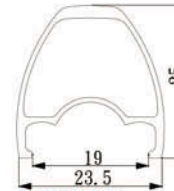

GTD25
Sleeved joint
Size:700C/650C

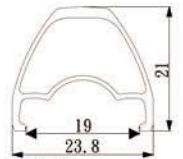

X35
Sleeved / Weld joint
Size:700C /650B

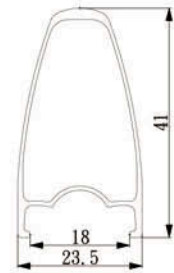

XRD
Weld joint
Size:700C

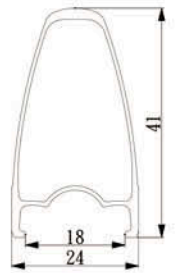

XRV
Weld joint
Size:700C

MTB for tubeless ready

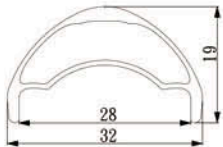

MB3.2h
Sleeved joint
Size:29"/27.5"(650B)

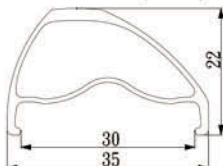

OCR3.5d
Sleeved joint
Size:29"/27.5"(650B)

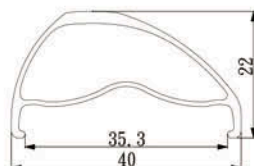

OCR4.0d
Sleeved joint
Size:29"/27.5"(650B)

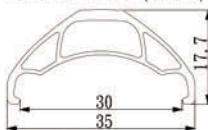

MB3.5
Sleeved joint
Size:29"/27.5"(650B)

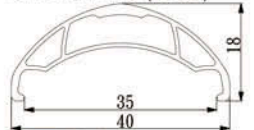

MB4.0
Sleeved joint
Size:29"/27.5"(650B)

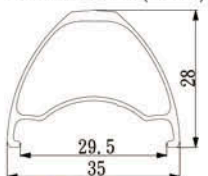

GTD35
Sleeved / Weld joint
Size:29"/27.5"(650B)

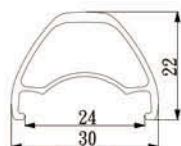

GTD30
Sleeved / Weld joint
Size:29"/27.5"(650B)

Mini Velo Bike

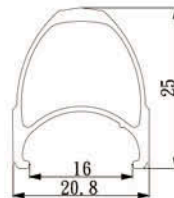

SR25
Sleeved joint
Size:451/406/355/349

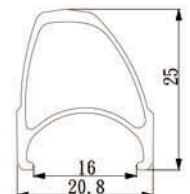

OCR25 - 16
Sleeved joint
Size:451/406/355/349

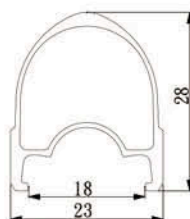

ER28
Sleeved joint
Size:451/406/355/349

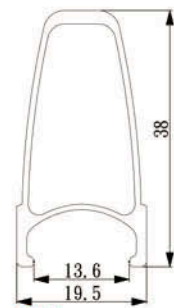

XF
Weld joint
Size:451/406

ASU
金特工業有限公司
GIN TER INDUSTRY CO., LTD.
www.rim-factory.com
ADD: 1, Lane 426, Sec. 3, jinma Rd.
Changhua, Taiwan.
E-mail: asucycle@gmail.com
TEL: +886-4-7281896
FAX: +886-4-7281796



HC-X351

SPOKE	32H 36H
FINISH	COLOR
OPTIONS	W/CNC
JOINT	PINNED

SIZE	WEIGHT (g)
20"x2.0"-3.0"/40x34	558g



HC-X353

SPOKE	32H 36H
FINISH	COLOR
OPTIONS	W/CNC
JOINT	SLEEVED

SIZE	WEIGHT (g)
20"x1-1/8"/451X21 20"/40x21	396g 355g



HC-X355

SPOKE	32H 36H
FINISH	COLOR
OPTIONS	-
JOINT	SLEEVED

SIZE	WEIGHT (g)
20"x1-1/8"/451X18 20"/40x18	335g 296g



HC-339

SPOKE	32H 36H
FINISH	COLOR
OPTIONS	W/CNC
JOINT	PINNED

SIZE	WEIGHT (g)
20"x2.0"-3.0"/40x34 16"x1-1/4"/34x34	560g 482g



HC-313

SPOKE	32H 36H
FINISH	COLOR
OPTIONS	-
JOINT	PINNED

SIZE	WEIGHT (g)
700cx1.75"-1.95"/622x25	684g
27.5"x1.75"-1.95"/584x25	635g
26"x1.75"-1.95"/559x25	598g
24"x1.75"-1.95"/507x25	564g
20"x1.75"-1.95"/40x25	450g
18"x1.75"-1.95"/355x25	400g



HC-315

SPOKE	32H 36H
FINISH	COLOR
OPTIONS	W/CNC
JOINT	PINNED

SIZE	WEIGHT (g)
27.5"x1.75"-1.95"/584x30	706g
20"x1.75"-1.95"/40x25	480g
18"x1.75"-1.95"/355x30	415g
16"x1-3/8"x1.75"-1.95"/349x30	408g



HC-513W

SPOKE	32H 36H
FINISH	COLOR
OPTIONS	W/CNC
JOINT	WELODED PINNED

SIZE	WEIGHT (g)
20"x1.75"-1.95"/40x30	488g



HC-317

SPOKE	32H 36H
FINISH	COLOR
OPTIONS	-
JOINT	WELODED

SIZE	WEIGHT (g)
20"x1.75"-1.95"/40x28	430g



HC-335

SPOKE	32H 36H
FINISH	COLOR
OPTIONS	W/CNC W/Eyelets
JOINT	PINNED

SIZE	WEIGHT (g)
29"x1.75"-1.95"/622x26	680g
27.5"x1.75"-1.95"/584x26	645g
26"x1.75"-1.95"/559x26	610g
24"x1.75"-1.95"/507x26	550g
20"x1.75"-1.95"/40x26	420g
18"x1.75"-1.95"/355x26	390g



HC-337

SPOKE	32H 36H
FINISH	COLOR
OPTIONS	W/Eyelets
JOINT	PINNED

SIZE	WEIGHT (g)
27.5"x2.125"/584x26	555g
24"x2.125"/507x26	470g
20"x2.125"/40x26	415g
18"x2.125"/355x26	370g



CH-300A

SPOKE	28H 32H 36H
FINISH	COLOR
OPTIONS	W/CNC W/Eyelets
JOINT	PINNED

SIZE	WEIGHT (g)
700C	764g
26"x1.75"-2.125"/559x24	670g
24"x1.75"-2.125"/507x24	600g
20"x1.75"-2.125"/40x24	480g
18"x1.75"-2.125"/355x24	425g
16"x1.75"-2.125"/305x24	370g



JS-30

SPOKE	28H 32H 36H
FINISH	COLOR
OPTIONS	W/CNC W/Eyelets
JOINT	PINNED

SIZE	WEIGHT (g)
20"x1.75"-2.125"/40x24	510g



HC-113

SPOKE 32H 36H
FINISH COLOR
OPTIONS W/CNC I W/Eyelets
JOINT PINNED

SIZE	WEIGHT (g)
20"x2.4"~3.0" / 40x40	606g
24"x2.4"~3.0" / 507x40	784g



HC-515A

SPOKE 28H 32H
FINISH COLOR
OPTIONS W/CNC I W/Eyelets
JOINT PINNED

SIZE	WEIGHT (g)
26"x2.125" / 559x40	575g (W/1Holes)
24"x2.125" / 507x40	468g
20"x2.125" / 406x40	527g
19"x2.125" / 387x40	389g (W/SingleTHoles)



HC-533S

SPOKE 28H 32H
FINISH COLOR
OPTIONS W/CNC
JOINT PINNED

SIZE	WEIGHT (g)
27.5"x2.125"~3.0" / 584x40	690g
26"x2.125"~3.0" / 559x40	557g (W/Tridles)
19"x2.125"~3.0" / 387x40	394g (W/SingleTHoles)



HS-28

SPOKE 28H 32H
FINISH COLOR
OPTIONS W/CNC | W/Eyelets
JOINT PINNED

SIZE	WEIGHT (g)
28"x2.125" / 559x32	559g
24"x2.125" / 507x32	485g
20"x2.125" / 406x32	409g
19"x2.125" / 387x32	437g



CH-23F

SPOKE 28H 32H
FINISH COLOR
OPTIONS W/CNC | W/Eyelets
JOINT PINNED

SIZE	WEIGHT (g)
26"x1.75"~2.125" / 559x24	530g
24"x1.75"~2.125" / 507x24	480g
20"x1.75"~2.125" / 406x24	408g
18"x1.75"~2.125" / 355x24	346g
16"x1.75"~2.125" / 305x24	300g
14"x1.75"~2.125" / 254x24	240g

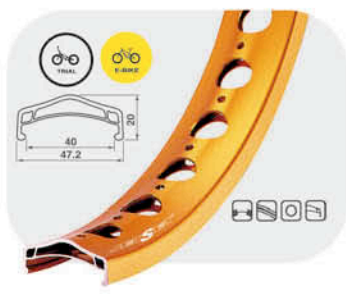

HS-2002

SPOKE 28H 32H
FINISH COLOR
OPTIONS W/CNC | W/Eyelets
JOINT PINNED

SIZE	WEIGHT (g)
27.5"x2.125" / 584x40	902g
26"x2.125" / 559x40	740g
24"x2.125" / 507x40	670g
20"x2.125" / 406x40	530g
19"x2.125" / 387x40	490g



HC-2002S

SPOKE 28H 32H
FINISH COLOR
OPTIONS W/CNC | W/Eyelets
JOINT PINNED

SIZE	WEIGHT (g)
26"x2.125" / 559x32	610g
24"x2.125" / 507x32	550g
20"x2.125" / 406x32	430g
16"x2.125" / 305x32	350g
12"x2.125" / 203x32	226g



HC-511

SPOKE 28H 32H
FINISH COLOR
OPTIONS W/CNC | W/Eyelets
JOINT PINNED

SIZE	WEIGHT (g)
700C2.125"~3.0" / 622x43	995g
27.5"x2.125"~3.0" / 584x43	935g
26"x2.125"~3.0" / 559x43	775g
24"x2.125"~3.0" / 507x43	700g
20"x2.125"~3.0" / 406x43	550g
19"x2.125"~3.0" / 387x43	510g



HC-DOWN33

SPOKE 32H 36H
FINISH COLOR
OPTIONS W/CNC I W/Eyelets
JOINT PINNED

SIZE	WEIGHT (g)
27.5"x2.125" / 584x26	794g
26"x2.125" / 559x26	785g



HC-DOWN35

SPOKE 32H 36H
FINISH COLOR
OPTIONS W/Eyelets
JOINT PINNED

SIZE	WEIGHT (g)
700C2.125"~3.25" / 622x26	662g
27.5"x2.125"~3.25" / 584x26	628g
26"x2.125"~3.25" / 559x26	603g



JS-DOWNZ

SPOKE 32H 36H
FINISH COLOR
OPTIONS W/CNC I W/Eyelets
JOINT PINNED

SIZE	WEIGHT (g)
700C2.125" / 622x35	900g
24"x2.125" / 559x35	807g
24"x2.125" / 507x35	725g



JS-2002

SPOKE 32H 36H
FINISH COLOR
OPTIONS W/CNC | W/Eyelets
JOINT PINNED

SIZE	WEIGHT (g)
36"	1080g
26"x2.125" / 559x35	770g
24"x2.125" / 507x35	695g
22"x2.125" / 456x35	625g
20"x2.125" / 406x35	565g
19"x2.125" / 387x35	520g
16"(1-3/8") / 305(349)x35	420(446)g



HC-517A

SPOKE 32H 36H
FINISH COLOR
OPTIONS W/Eyelets
JOINT PINNED

SIZE	WEIGHT (g)
26" / 559x64	1040g
26" / 559x64	950g (W/Circle Holes)
24" / 507x64	849g (W/Circle Holes)
20" / 406x64	724g (W/Circle Holes)



HC-3579

SPOKE 32H 36H 64H
FINISH COLOR
OPTIONS W/Eyelets
JOINT PINNED

SIZE	WEIGHT (g)
26" / 559x76	1170g
26" / 559x76	1050g (W/Circle Holes)
26" / 559x76	940g (W/□Holes)
24" / 507x76	885g (W/Double Circle Holes)



HC-5799

SPOKE 32H 36H 64H
FINISH COLOR
OPTIONS W/Eyelets
JOINT PINNED

SIZE	WEIGHT (g)
26" / 559x93	1300g
26" / 559x93	1048g (W/□Holes)
24" / 507x93	1195g

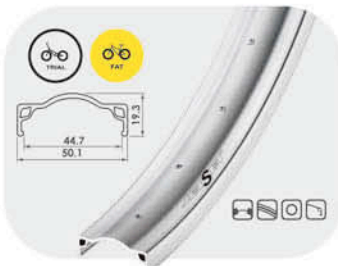

CH-513S

SPOKE 32H 36H
FINISH COLOR
OPTIONS W/CNC | W/Eyelets
JOINT PINNED

SIZE	WEIGHT (g)
700C / 622x45	850g
26" x3.0" / 559x45	750g
27.5" / 584x45	800g
24" / 507x45	690g
20" / 406x45	548g
18" / 355x45	482g
16" / 305x45	414g



HC-E337W

SPOKE 32H 36H
FINISH COLOR
OPTIONS W/Eyelets
JOINT WELDED

SIZE	WEIGHT (g)
27.5" / 584x26	494g



HC-399

SPOKE 32H 36H
FINISH COLOR
OPTIONS W/Eyelets
JOINT PINNED

SIZE	WEIGHT (g)
29" / 622x50	745g
27.5" / 584x50	678g
26" / 559x50	650g



HC-E339

SPOKE 32H 36H
FINISH COLOR
OPTIONS W/Eyelets
JOINT SLEEVED

SIZE	WEIGHT (g)
29" / 622x39	470g
27.5" / 584x39	418g



HC-E331

SPOKE 28H 32H 36H
FINISH COLOR
OPTIONS W/Eyelets
JOINT PINNED

SIZE	WEIGHT (g)
29" x2.1" - 3.25" / 622x26	630g
27.5" (650B)x2.1" - 3.25" / 584x26	588g
26" x2.1" - 3.25" / 559x26	570g



HC-397

SPOKE 28H 32H 36H
FINISH COLOR
OPTIONS W/Eyelets
JOINT SLEEVED

SIZE	WEIGHT (g)
29" x2.125" - 3.25" / 622x26	594g
27.5" (650B) x2.125" - 3.25" / 584x26	558g



HC-355T

SPOKE 28H 32H
FINISH COLOR
OPTIONS W/Eyelets
JOINT SLEEVED

SIZE	WEIGHT (g)
29" x1.5" - 1.75" / 622x18	454g
27.5" (650B) x1.5" - 1.75" / 584x18	424g



HC-358

SPOKE 28H 32H 36H
FINISH COLOR
OPTIONS W/Eyelets
JOINT PINNED

SIZE	WEIGHT (g)
29" / 622x17	480g
27.5" (650B) / 584x17	440g
26" x1.5" - 1.75" (1-3/8") / 559 (590)	420g (455g)
24" x1-3/8" / 540x17	412g



HC-393

SPOKE 28H 32H
FINISH COLOR
OPTIONS W/Eyelets
JOINT PINNED

SIZE	WEIGHT (g)
29" / 622x21	580g
27.5" (650B) / 584x21	545g
26" / 559x21	520g
24" / 520x21	493g
20" / 406x21	384g



CH-E210

SPOKE	32H 36H
FINISH	COLOR
OPTIONS	W/CNC W/Eyelets
JOINT	PINNED

SIZE	WEIGHT (g)
700C / 622x14	420g
24"x1.5"-1.75" / 559x14	550g
24"x1.5"-1.75" / 507x14	500g
20"x1.5"-1.75" (1-1/8") / 404(451)x14	400g(440g)
18"x1.5"-1.75" / 355x14	355g
14"x1.5"-1.75" (1-1/8") / 305(349)x14	295g(330g)
14"x1.5"-1.75" / 254x14	255g



CH-E211

SPOKE	32H 36H
FINISH	COLOR
OPTIONS	W/CNC W/Eyelets
JOINT	PINNED

SIZE	WEIGHT (g)
700C / 622x14	530g
24"x1.5"-1.75" / 559x14	475g
24"x1.5"-1.75" (1-1/8") / 507 (520) x14	425g(435g)
20"x1.5"-1.75" (1-1/8") / 404 (451)x14	350g(380g)
14"x1.5"-1.75" (1-1/8") / 305(349)x14	265g(270g)
14"x1.5"-1.75" / 254x14	210g



CH-E213

SPOKE	32H 36H
FINISH	COLOR
OPTIONS	W/CNC W/Eyelets
JOINT	PINNED

SIZE	WEIGHT (g)
700C x1.75"-1.95" / 622x21	700g
27.5"x1.75"-1.95" / 584x21	458g
24"x1.75"-1.95" / 559x21	630g
24"x1.75"-1.95" / 507x21	570g
20"x1.75"-1.95" (1-1/8") / 404(451)x21	455g(510g)
16"x1.75"-1.95" (1-1/8") / 305(349)x21	330g(390g)



CH-E220

SPOKE	32H 36H
FINISH	COLOR
OPTIONS	W/CNC
JOINT	PINNED

SIZE	WEIGHT (g)
700C / 622x14	590g
24"x1.5" / 559x14	520g
24"x1.5" / 507x14	470g
20"x1.5" (1-1/8") / 404(451)x14	390g(429g)
18"x1.5" / 355x14	320g
14"x1.5" (1-1/8") / 305(349)x14	280g(314g)



CH-E240

SPOKE	32H 36H
FINISH	COLOR
OPTIONS	W/CNC W/Eyelets
JOINT	PINNED

SIZE	WEIGHT (g)
700C / 622x18	580g
24"x1-3/8" / 590x18	550g
27.5" (650B) / 584x18	540g
26"x1.5"-1.75" / 559x18	520g
24"x1.5"-1.75" / 507x18	470g
20"x1.5"-1.75" / 406x18	380g
18"x1.5"-1.75" / 355x18	324g
14"x1.5"-1.75" (1-1/8") / 305(349)x18	280g(320g)
14"x1.5"-1.75" / 254x18	240g



CH-E270

SPOKE	32H 36H
FINISH	COLOR
OPTIONS	W/CNC
JOINT	PINNED

SIZE	WEIGHT (g)
700C / 622x18	730g
27.5" / 584x18	670g
24"x1.75"-1.95" (1-3/8") / 559(590)x18	655g(710g)
24"x1.75"-1.95" / 507x18	590g
20"x1.75"-1.95" / 406x18	470g



JS-913

SPOKE	20H 24H
FINISH	COLOR
OPTIONS	W/CNC
JOINT	SLEEVED

SIZE	WEIGHT (g)
700C/622x20	484g
27.5"/584x20	470g



HC-391

SPOKE	28H 32H
FINISH	COLOR
OPTIONS	W/CNC W/Eyelets
JOINT	SLEEVED

SIZE	WEIGHT (g)
26" / 559x14	445g
20"x1-3/8" / 451x14	356g
20" / 406x14	320g
18" / 355x14	276g



JS-190

SPOKE	24H 28H 32H 36H
FINISH	COLOR
OPTIONS	W/CNC
JOINT	PINNED

SIZE	WEIGHT (g)
700C / 622x14	580g
24"x1.0" (A50C) / 571x14	530g
24"x1.0" / 520x14	480g
20"x1-1/8" / 451x14	420g



JS-340L

SPOKE	28H 32H 36H
FINISH	COLOR
OPTIONS	W/CNC W/Eyelets
JOINT	SLEEVED

SIZE	WEIGHT (g)
700C / 622x13	395g
24"x1-3/8" / 590x13	355g
24"x1.0" / 520x13	326g
20"x1-3/8" / 451x13	285g



JS-380L

SPOKE	24H 28H 32H 36H
FINISH	COLOR
OPTIONS	W/Single Double Eyelets
JOINT	SLEEVED

SIZE	WEIGHT (g)
27"x1-1/4"-430x13	505g
700C / 622x13	440g
27.5" (A50B) / 584x13	430g
26"x1.0" (680C) / 571x13	420g
24"x1.0" / 520x13	370g
20"x1-1/8" / 451x13	320g



JS-680L

SPOKE	24H 28H 32H 36H
FINISH	COLOR
OPTIONS	W/CNC
JOINT	PINNED

SIZE	WEIGHT (g)
27"x1-1/4" / 430x12	440g
700x18C-23C / 622x12	420g
26"x1.0" (A60C) / 571x12	580g
24"x1.0" / 520x12	530g



和駿成企業股份有限公司
HER JIUNN CHENG ENTERPRISE CO., LTD.
 No. 50, Hsing Kung Rd., Chuan Hsing Ind. Area,
 Shengkang, Changhua County 509, Taiwan
Tel: +886-4-7990737-8 Fax: +886-4-7990020
E-mail: herjiunn@ms10.hinet.net

f 和駿成企業股份有限公司粉絲專頁

廣東省佛山市順德區-
 和駿成五金制品有限公司
Tel: 0757-28669391 Fax: 0757-28669390
Email: hjccn@hjccn.cn
Web: www.hjccn.cn
Postcode: 528300

無錫和駿成車業有限公司
 No.19 Chunhui Zhong Road, Xishan
 Economic, Development Zone, Wuxi Jiangsu
 Province, China
Tel: 0510-83770568 Fax: 0510-83770698
Email: wuxihjc@163.com



DA-500S

Double wall
 Holes: 28H 32H 36H 48H
 Gauges: 14G 13G 12G
 700C
 Silver anodized
 Optional: Color

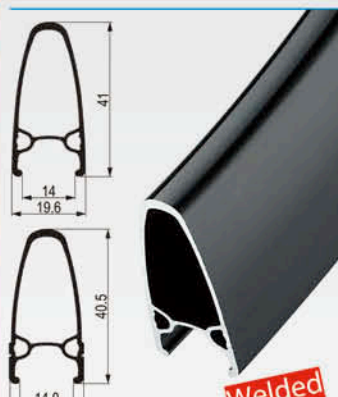

DA-400S/DA-410(DISC)

Double wall
 Holes: 28H 32H 36H 48H
 Gauges: 14G 13G 12G
 20x25C 20x1-3/8 700C
 Silver anodized
 Optional: Color CNC side wall
 Weight:580g(700C Welded)



DA-302S

Double wall
 Holes: 28H 32H 36H
 Gauges: 14G 13G
 16x13/8 18x25C 20x25C 20x13/8 650C 700C
 Silver anodized
 Optional: CNC, side wall, color, eyelets



DA-240

Double wall
 Holes: 28H 32H 36H
 Gauges: 14G 13G
 16x13/8 18x25C 20x25C 20x13/8 650C 700C
 Silver anodized
 Optional: CNC, side wall, color



DA-230S

Double wall
 Holes: 28H 32H 36H
 Gauges: 14G 13G
 20x25C 20x1-3/8 700C
 Silver anodized
 Optional: CNC, side wall, color



DP-153 / DP-153S DISC

Double wall
 Holes: 28H 32H 36H
 Gauges: 14G 13G 12G
 20x25C 20x13/8* 24x25C 26x25C 650C 700C
 Silver anodized
 Optional: color, eyelets



DA-301S

Double wall
 Holes: 28H 32H 36H
 Gauges: 14G 13G
 24x1.5 26x1.5 650B 700C
 Silver anodized
 Optional: CNC, side wall, color, eyelets



DA-17 / DA-17S

Double wall
 Holes: 32H 36H
 Gauges: 14G 13G
 24x1.5 24x1.5 26x1.5 650B 700C
 20x13/8 22x13/8 24x13/8 26x13/8
 Silver anodized
 Optional: CNC, side wall, color, eyelets



DX-188 DISC

Double wall
 Holes: 32H 36H
 Gauges: 14G 13G
 20x1.5 24x1.5 26x1.5 650B 700C
 20x13/8 22x13/8 24x13/8 26x13/8
 Silver anodized
 Optional: color, eyelets



DX-225 DISC

Double wall
 Holes: 32H 36H
 Gauges: 14G 13G
 20x1.5 24x1.5 26x1.5 650B 700C
 Silver anodized
 Optional: Color



DX-281 DISC

Double wall
 Holes: 32H 36H
 Gauges: 14G 13G
 20x1-3/8 20x1.5 24x1.5 26x1.5 650B 700C
 Silver anodized
 Optional: Color eyelets



DA-16S

Double wall
 Holes: 16H 20H 24H 28H 32H 36H
 Gauges: 14G 13G
 16"x1.5 16"x1-3/8 20x1.5 20x13/8 24x1.5
 26x1.5 650B 650C 700C
 Silver anodized
 Optional: CNC, side wall, color



DA-24/DA-24S

Double wall
 Holes: 32H 36H
 Gauges: 14G 13G
 20x1.5 24x1.5 26x1.5 650B 700C
 Silver anodized
 Optional: CNC, side wall, color



DP-18S

Double wall
 Holes: 20H 28H 32H 36H
 Gauges: 14G 13G
 20x1.5 24x1.5 26x1.5 700C
 Silver anodized
 Optional: CNC, side wall, color, eyelets



DP-19S

Double wall
 Holes: 20H 28H 32H 36H
 Gauges: 14G 13G
 20x1.5 20x13/8 24x1.5 26x1.5 650B 700C
 Silver anodized
 Optional: CNC, side wall, color, eyelets



DP-26 / DP26S

Double wall
 Holes: 32H 36H
 Gauges: 14G 13G
 20x13/8 24x13/8 26x13/8 700C
 Silver anodized
 Optional: GSW, color, eyelets



DA-28

Double wall
 Holes: 32H 36H
 Gauges: 14G 13G
 20x1.5 24x1.5 26x1.5 650B 700C
 Silver anodized
 Optional: CNC, side wall, color, eyelets



DMP-341

Double wall
 Holes: 28H, 32H, 36H
 Gauges: 14G, 13G
 18"x2.125 20"x2.125 24"x2.125
 26"x2.125 700C
 Silver anodized
 Optional: GSW, color



DMP-342

Single wall
 Holes: 28H 36H 48H
 Gauges: 14G 13G 12G
 18x2.125 20x2.125 24x2.125 26x2.125
 Silver anodized
 Optional: GSW, color, eyelets



DMP-36

Double wall
 Holes: 32H 36H
 Gauges: 14G 13G 12G
 18x2.125 20x2.125 24x2.125 26x2.125
 Silver anodized
 Optional: GSW, color



DA-325

Double wall
 Holes: 24H 28H 32H 36H 48H
 Gauges: 14G 13G
 20"x2.125 24"x2.125 26"x2.125 36"x2.125
 Silver anodized
 Optional: GSW, color, eyelets



DM-350

Double wall
 Holes: 32H 36H 48H
 Gauges: 14G 13G 12G
 20x2.125 24x2.125 26x2.125 36"x2.125
 Silver anodized
 Optional: GSW, eyelets, color

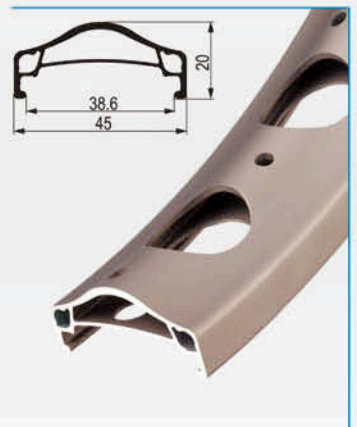

DA-451

Tubeless Ready

Double wall
 Holes: 32H 36H
 Gauges: 14G 13G
 19"x2.6 20"x2.6 24"x2.6 26"x2.6 27.5+3.0
 Silver anodized
 Optional: GSW, color, eyelets

			
<p>Model SDA-14</p> <p>Double wall Holes: 20H,24H,28H,32H,36H Gauges:12G, 13G, 14G 700C 622 X14 Silver anodizing OPTIONAL:CNC side walls/ ground side walls /color</p>	<p>Model DA-17</p> <p>Double wall Holes:24H, 28H, 32H, 36H Gauges:12G,13G,14G 24" 507×17 26" 559×17 700C 622×17 Silver anodizing OPTIONAL:CNC side walls ground side walls eyelets</p>	<p>Model DA-18</p> <p>Double wall Holes: 24H,28H, 32H, 36H Gauges:12G,13G,14G 20" 406×17 24" 507×17 26" 559×17 27.5(650B) 584×20 700C 622×20 Silver anodizing OPTIONAL:CNC side walls ground side walls</p>	<p>Model DA-20</p> <p>Double wall Holes:28H.32H.36H Gauges:12G.13G.14G 24" 507×13 26" 559×13 700C 622×13 Silver anodizing OPTIONAL:CNC side walls ground side walls eyelets</p>
			
<p>Model DA-24</p> <p>Double wall Holes:24H, 28H, 32H, 36H Gauges:12G,13G,14G 20" 406×18 24" 507×18 26" 559×18 27.5(650B) 584×18 700C 622×18 Silver anodizing OPTIONAL:CNC side walls ground side walls</p>	<p>Model DA-26</p> <p>Double wall(DISC) Holes:28H.32H.36H Gauges:12G.13G.14G 26" 559×20 27.5(650B) 584×20 700C 622×20 Silver anodizing OPTIONAL:Side walls eyelets</p>	<p>Model DA-230</p> <p>Double wall Holes:24H, 28H, 32H, 36H Gauges:12G,13G,14G 650C 571×13 700C 622×13 Silver anodizing OPTIONAL:CNC side walls ground side walls</p>	<p>Model DA-270</p> <p>Double wall Holes:24H, 28H, 32H, 36H Gauges:12G,13G,14G 24" 507×16 26" 559×16 700C 622×16 Silver anodizing OPTIONAL:CNC side walls ground side walls color eyelets</p>
			
<p>Model DA-280</p> <p>Double wall Holes:24H, 28H, 32H, 36H Gauges:12G,13G,14G 650C 571×13 700C 622×13 Silver anodizing OPTIONAL:CNC side walls ground side walls</p>	<p>Model DA-300</p> <p>Double wall Holes:32H , 36H Gauges:14G , 13G , 12G 24" 507×18 26" 559×18 700C 622×18 Silver anodizing OPTIONAL:CNC side walls ground side walls</p>	<p>Model DA-350(DISC)</p> <p>Double wall Holes: 32H, 36H Gauges:12G,13G,14G 20" 406×28 24" 507×28 26" 559×28 700C 622×28 Silver anodizing OPTIONAL: eyelets/color</p>	<p>Model DA-400</p> <p>Double wall Holes:28H.32H.36H Gauges:12G.13G.14G 700C 622×13 Silver anodizing OPTIONAL:CNC Side walls ground Side walls color</p>

			
<p>Model DA-600</p> <p>Double wall Holes:24H, 28H, 32H, 36H Gauges:12G,13G,14G 24" 507×16 26" 559×16 Silver anodizing OPTIONAL: eyelets</p>	<p>Model DA-2000</p> <p>Double wall Holes:28H.32H.36H Gauges:12G,13G,14G 24" 507×19 26" 559×19 700C 622×21 □ Silver anodizing OPTIONAL: eyelets</p>	<p>Model DA-6000</p> <p>Double wall(DISC) Holes:28H.32H.36H Gauges:12G.13G.14G 26" 559×21 27.5(650B) 584×21 700C 622×21 Silver anodizing OPTIONAL:Side walls eyelets</p>	<p>Model DP-15</p> <p>Double wall Holes: 32H, 36H Gauges:12G,13G,14G 20" 406×15 24" 507×15 26" 559×15 700C 622×15 Silver anodizing OPTIONAL:CNC side walls ground side walls /color/eye lets</p>
			
<p>Model DP-19</p> <p>Double wall Holes:28H.32H.36H Gauges:12G.13G.14G 20" 406×19 24" 507×19 26" 559×19 27.5(650B) 584×19 700C 622×19 Silver anodizing OPTIONAL:CNC side walls ground side walls eye lets</p>	<p>Model DP-21</p> <p>Double wall Holes:28H.32H.36H Gauges:12G.13G.14G 24" 507×21 26" 559×21 29" 622×21 27.5 (650B) 584×21 700C 622×21 Silver anodizing OPTIONAL:CNC side walls ground side walls eyelets</p>	<p>Model DP-24</p> <p>Double wall Holes:32H, 36H Gauges:12G,13G,14G 20" 406×24 24" 507×24 26" 559×24 700C 622×24 Silver anodizing OPTIONAL:CNC side walls ground side walls eyelets</p>	<p>Model DP-32</p> <p>Double wall Holes:28H.32H.36H Gauges:12G.13G.14G 20" 406×25 24" 507×25 26" 559×25 700C 622×25 Silver anodizing OPTIONAL:CNC side walls ground side walls</p>
			
<p>Model DP-50</p> <p>Double wall Holes:32H, 36H Gauges:12G,13G,14G 20" 406×14 24" 507×14 26" 559×14 700C 622×14 Silver anodizing OPTIONAL: ground side walls color eyelets</p>	<p>Model DM-300</p> <p>Double wall Holes:32H, 36H Gauges:12G,13G,14G 20" 406×24 24" 507×24 26" 559×24 Silver anodizing OPTIONAL:CNC side walls ground side walls</p>	<p>Model P-32</p> <p>Single wall (DISC) Holes: 28H, 32H, 36H Gauges:12G,13G,14G 20" 406×26 24" 507×26 26" 559×26 700C 622×26 Silver anodizing OPTIONAL:CNC side walls ground side walls</p>	<p>Model P-800</p> <p>Single wall Holes:32H, 36H Gauges:12G, 13G, 14G 24" 507×74 26" 559×74 Silver anodizing OPTIONAL:ground side walls / color</p>



DISC-AP23

Size: 24", 26", 700C (1.75-2.125)
 Optional: W/O, Silver, Black, Color
 (ED, powder / Liquid coated, Anodized)
 S.Holes: 20H, 24H, 28H, 32H, 36H
 Joint: sleeved / Pinned
 Gauges: 13G / 14G
 Finish: CNC, GSW, safty-lines



DA-380

Size: 26" (1.95-3.0)
 Optional: W/O, Silver, Black
 (ED, powder / Liquid coated, Anodized)
 S.Holes: 28H, 32H, 36H, 48H
 Joint: Pinned
 Gauges: 13G / 14G
 Finish: CNC, GSW, Eyelets, safty-lines



DP-300

Size: 24", 26", 700C (1.5-1.95)
 Optional: W/O, Silver, Black
 (ED, powder / Liquid coated, Anodized)
 S.Holes: 24H, 28H, 32H, 36H
 Joint: Pinned
 Gauges: 13G / 14G
 Finish: CNC, GSW, Eyelets, safty-lines



DISC-AP19

SIZE: 20" 24" 26" [650B] 29" (1.5 - 1.95)
 OPTIONAL: W/O, Silver, Black.
 (ED, Powder/liquid Coated, Anodized)
 S.HOLES: 24H, 28H, 32H, 36H, 48H.
 JOINT: Pinned
 GAUGES: 13G/14G
 FINISH: Eyelets.



DA-280

Size: 26", 700C (18C/23C)
 Optional: W/O, Silver, Black
 (ED, powder / Liquid coated, Anodized)
 S.Holes: 16H, 20H, 24H, 32H, 36H
 Joint: Pinned
 Gauges: 13G / 14G
 Finish: CNC, GSW, safty-lines



DA-21

Size: 26", 700C (1.75-1.95)
 Optional: W/O, Silver, Black
 (ED, powder / Liquid coated, Anodized)
 S.Holes: 20H, 24H, 32H, 36H
 Joint: Pinned
 Gauges: 13G / 14G
 Finish: CNC, GSW, Eyelets, safty-lines



DA-20

Size: 26", 700C (18C/23C)
 Optional: W/O, Silver, Black
 (ED, powder / Liquid coated, Anodized)
 S.Holes: 20H, 24H, 32H, 36H
 Joint: Pinned
 Gauges: 13G / 14G
 Finish: CNC, GSW, safty-lines

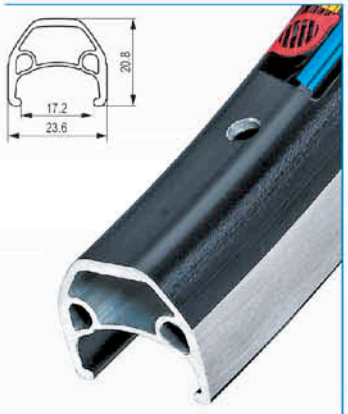

DA-18

Size: 26", 700C (1.5-1.95)
 Optional: W/O, Silver, Black
 (ED, powder / Liquid coated, Anodized)
 S.Holes: 20H, 24H, 32H, 36H
 Joint: Pinned
 Gauges: 13G / 14G
 Finish: CNC, GSW, Eyelets, safty-lines



DA-14

Size: 26", 700C (18C/23C)
 Optional: W/O, Silver, Black
 (ED, powder / Liquid coated, Anodized)
 S.Holes: 20H, 24H, 32H, 36H
 Joint: Pinned
 Gauges: 13G / 14G
 Finish: CNC, GSW, safty-lines



DP-38

Size: 20", 24", 26" (1.95-3.0)
 Optional: W/O, Silver, Black
 (ED, powder / Liquid coated, Anodized)
 S.Holes: 32H, 36H, 48H, 68H
 Joint: Pinned
 Gauges: 13G / 14G
 Finish: CNC, GSW, Eyelets, safty-lines



DP-20

Size: 20"- 700C (18C/23C)
 Optional: W/O, Silver, Black
 (ED, powder / Liquid coated, Anodized)
 S.Holes: 20H, 24H, 32H, 36H
 Joint: Pinned
 Gauges: 13G / 14G
 Finish: CNC, GSW, Eyelets, safty-lines

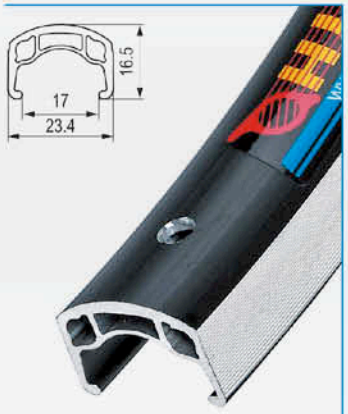

DP-17

Size: 20"- 700C (1.5-1.95)
 Optional: W/O, Silver, Black
 (ED, powder / Liquid coated, Anodized)
 S.Holes: 20H, 24H, 32H, 36H
 Joint: Pinned
 Gauges: 13G / 14G
 Finish: CNC, GSW, Eyelets, safty-lines



DISC-21

Size: 24", 26", 700C (1.5-1.95)
 Optional: W/O, Silver, Black, Color
 (ED, powder / Liquid coated, Anodized)
 S.Holes: 20H, 24H, 28H, 32H, 36H
 Joint: sleeved / Pinned
 Gauges: 13G / 14G
 Finish: CNC, GSW, safty-lines



DISC-01

SIZE: 20" 24" 26" [650B] 29"(1.5 - 1.75)
 OPTIONAL: W/O, Silver, Black.
 (ED, Powder/Liquid Coated, Anodized)
 S.HOLES: 24H, 28H, 32H, 36H, 48H, 68H.
 JOINT: Pinned
 GAUGES: 13G/14G
 FINISH: Eyelets.



MP-34

Size: 16", 20", 24", 26"(1.95-2.125)
 Optional: W/O, Silver, Black
 (ED, powder / Liquid coated, Anodized)
 S.Holes: 24H, 28H, 32H, 36H
 Joint: Pinned
 Gauges: 13G / 14G
 Finish: CNC, GSW, safty-lines



DISC-19

SIZE: 20" 24" 26" [650B] 29"(1.5 - 1.95)
 OPTIONAL: W/O, Silver, Black.
 (ED, Powder/Liquid Coated, Anodized)
 S.HOLES: 24H, 28H, 32H, 36H, 48H.
 JOINT: Pinned
 GAUGES: 13G/14G
 FINISH: Eyelets.



P-50

Size: 20", 24", 26"(2.125-3.0)
 Optional: W/O, Silver, Black
 (ED, powder / Liquid coated, Anodized)
 S.Holes: 24H, 28H, 32H, 36H
 Joint: Pinned
 Gauges: 13G / 14G
 Finish: CNC, GSW, safty-lines

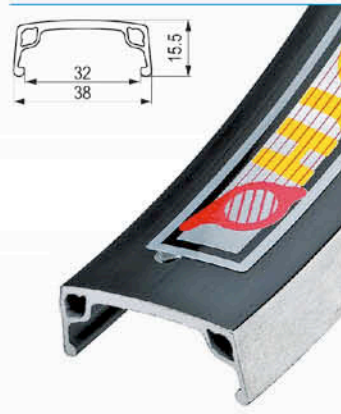

P-38

Size: 12", 14", 20", 24", 26"(1.95-3.0)
 Optional: W/O, Silver, Black
 (ED, powder / Liquid coated, Anodized)
 S.Holes: 24H, 28H, 32H, 36H
 Joint: Pinned
 Gauges: 13G / 14G
 Finish: CNC, GSW, Eyelets, safty-lines



P-20

Size: 12" 700C (1.5-1.95)
 Optional: W/O, Silver, Black
 (ED, powder / Liquid coated, Anodized)
 S.Holes: 24H, 28H, 32H, 36H
 Joint: Pinned
 Gauges: 13G / 14G
 Finish: CNC, GSW, Eyelets, safty-lines



DISC-23

SIZE: 20" 24" 26" [650B] 29"(1.5 - 1.95)
 OPTIONAL: W/O, Silver, Black.
 (ED, Powder/Liquid Coated, Anodized)
 S.HOLES: 24H, 28H, 32H, 36H, 48H.
 JOINT: Pinned
 GAUGES: 13G/14G
 FINISH: Eyelets.



DP-36

SIZE: 20" 24" 26" (1.5 - 2.5)
 OPTIONAL: W/O, Silver, Black.
 (ED, Powder/Liquid Coated, Anodized)
 S.HOLES: 24H, 28H, 32H, 36H, 68H, 140H
 JOINT: Pinned
 GAUGES: 13G/14G
 FINISH: Eyelets, GSW, CNC.

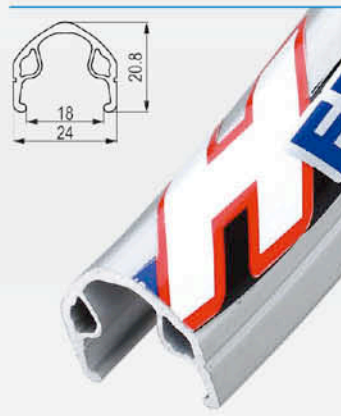

P-18S

Size: 12" 700C (1.5-1.95)
 Optional: W/O, Silver, Black
 (ED, powder / Liquid coated, Anodized)
 S.Holes: 28H, 32H, 36H, 48H
 Joint: Pinned
 Gauges: 13G / 14G
 Finish: CNC, GSW, safty-lines

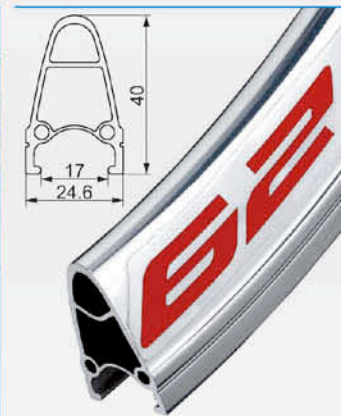

DH-400

SIZE: 26", [650B], 29"(1.5 - 1.95)
 OPTIONAL: W/O, Silver, Black.
 (ED, Powder/Liquid Coated, Anodized)
 S.HOLES: 24H, 28H, 32H, 36H, 68H,
 JOINT: Pinned
 GAUGES: 13G/14G
 FINISH: GSW, CNC.



DA-25

SIZE: 20" 24" 26" [650B] 29"(1.5 - 1.95)
 OPTIONAL: W/O, Silver, Black.
 (ED, Powder/Liquid Coated, Anodized)
 S.HOLES: 24H, 28H, 32H, 36H, 68H.
 JOINT: Pinned
 GAUGES: 13G/14G
 FINISH: Eyelets, GSW, CNC.



和駿成企業股份有限公司
HER JIUNN CHENG ENTERPRISE CO., LTD.
 No. 50, Hsing Kung Rd, Chuan Hsing Ind. Area,
 Shengkang, Changhua County 509, Taiwan
Tel: +886-4-7990737-8 **Fax:** +886-4-7990020
E-mail: herjiunn@ms10.hinet.net

廣東省佛山市順德區和駿成五金制品有限公司
GUANGDONG PROVINCE FOSHAN CITY SHUNDE HER JIUNN CHENG HARDWARE CO., LTD.
 Liandu Industrial Zone, Leliu shunde, Foshan, Guangdong China
Tel: 0757-28669391 • 28669392 • 28669896 **Fax:** 0757-28669390
Email: hjccn@hjccn.cn
Web: www.hjccn.cn **Postcode:** 528300



P-80X
 Size: 20"-29" (3.5"-4.0)
 Option: W/O, Silver, Black
 (ED, Powder/Liquid coated, Anodized)
 S.Holes: 28H, 32H, 36H, 48H.
 Joint: Pinned
 Gauges: 14G, 13G, 12G
 Finish: GSW, Eyelets.



DA-30 Double wall
 SIZE: 20"-29" (1.95"-2.5")
 OPTIONAL: W/O, Silver, Black
 (ED, Powder/Liquid coated, Anodized)
 S.HOLES: 20H, 28H, 32H, 36H.
 JOINT: Pinned
 GAUGES: 14G, 13G, 12G.
 FINISH: CNC GSW



DR-250
 Size: 20"-700C" (20C-23C)
 Option: W/O, Silver, Black
 (ED, Powder/Liquid coated, Anodized)
 S.Holes: 20H, 24H, 28H, 32H, 36H
 Joint: Pinned
 Gauges: 14G
 Finish: CNC, Gsw, Safty-lines



DISC-AP190 Double wall
 SIZE: 20"-29" (1.5"-1.95")
 OPTIONAL: W/O, Silver, Black
 (ED, Powder/Liquid coated, Anodized)
 S.HOLES: 20H, 28H, 32H, 36H.
 JOINT: Pinned
 GAUGES: 14G, 13G, 12G.
 FINISH: Eyelets

MTB-XC
 Rim: HJC DA-250 24H / 24H RED
 Hub: 24H / 24H; 4 sealed Bearings.
 O.L.D: F100 / R135;
 Material: AL-6061
 Color: Red, Pinned



DP-15
 Size: 12"-70C" (23C-25C)
 Option: W/O, Silver, Black
 (ED, Powder/Liquid coated, Anodized)
 S.Holes: 20H, 24H, 28H, 32H, 36H
 Joint: Pinned
 Gauges: 14G
 Finish: CNC, Gsw, Eyelets, Safty-lines



DISC-RP170 Double wall
 SIZE: 20"-29" (1.5"-1.95")
 OPTIONAL: W/O, Silver, Black
 (ED, Powder/Liquid coated, Anodized)
 S.HOLES: 20H, 28H, 32H, 36H.
 JOINT: Pinned
 GAUGES: 14G, 13G, 12G.
 FINISH: Eyelets



ROAD-GOLD
 Rim: HJC DA-280 20H / 24H Gold+CNC
 Hub: 20H / 24H; 4 sealed Bearings.
 O.L.D: F100 / R130;
 Material: AL-6061
 Color: Gold, Pinned

品亦冠工業有限公司

Pin Yi Guan Ind. Co., Ltd.

Tel: 886-4-8911755/ 886-48911759

Fax: 886-4-8928177

Email: kdrims@hotmail.com

www.kdrims.com



CX500

Aluminum 6061-T6

Joint Welded
 Diameter 700C 622x17
 Finish Polishing, Sandblasting, Brushing+Anodizing
 Weight 700g



KD RIMS
THE KINGDOM OF BICYCLE RIMS



OF250

Features

Offset Rims
 Tubeless Ready System

Tech Spec

Joint Welded, Sleeved
 Diameter 622 mm
 Weight 500g (622 mm)

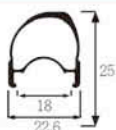

CX400

Features

High Profile with lightweight
 Durable with welded joint

Tech Spec

Joint Welded, Sleeved
 Diameter 622, 451, 406, 355, 349 mm
 Weight 560g (622 mm), 400g (451 mm)
 350g (406 mm), 320g (355 mm)
 315g (349 mm)

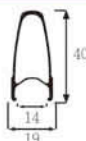

CX350

Features

Tubeless Ready System
 High and Fat shape

Tech Spec

Joint Welded, Sleeved
 Diameter 622, 451, 406 mm
 Weight 570g (622 mm)

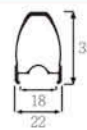

Options for all series of KD RIMS.

Size: 622 (700C), 559, 507, 451, 406, 355, 349mm

Finish: Polishing, Sandblasting, Brushing+Anodizing

Color: Various Colors of Anodizing or Powder Coated

Holes: Any combination of drilling holes.



CX300

Features

Lightweight
 Durable with welded joint

Tech Spec

Joint Welded, Sleeved
 Diameter 622, 451, 406, 355, 349 mm
 Weight 420g (622 mm)

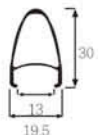

CX250

Features

Durable with welded joint

Tech Spec

Joint Welded, Sleeved
 Diameter 622, 451, 406, 355, 349 mm
 Weight 450g (622 mm)

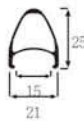

CX020

Features

Durable with welded joint

Tech Spec

Joint Welded, Sleeved
 Diameter 622, 451, 406, 355, 349 mm
 Weight 400g (622 mm)

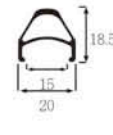

Customizing Your Own Bicycle Rims!

We offer service for customizing your own bike rims with high-quality performance. Contact us soon for your own brand.

享勵工業股份有限公司

Taiwan Factory

SHEANG LIH CYCLE INDUSTRY CO., LTD.

No.7, Hwan Gong Road, Yung Kang Dist., Tainan City, Taiwan Postal Code:71041
Tel:+886-6-2042077-8 Fax:+886-6-2337514

Vietnam Factory

SHEANG LIH CYCLE (VIETNAM) ENT. LTD.

No.21, Road DT743, Lot N, Song Than Industrial Zone II
Tan Dong Hiep Commune, Di An District, Binh Duong Province,
Vietnam Postal Code:824843

Tel:+84-274-3730188 Fax:+84-274-3730218

China Factory

BO YU METAL PRODUCTS CO., LTD.

No.158, Xinyuansan Road, Xinbei District, Changzhou City,
Jiangsu Province,China Postal Code:213031

Tel:+86-519-68586787-8 Fax:+86-519-68586779

E-Mail: slcycle@shining-cycle.com

A-360



Size	Weight(g)	ERD(mm)
700C(622-14)	527	584
Holes: 20H/24H/28H/32H/36H		
Option: GSW/CSW		
Joint: Sleeved		

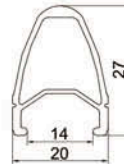

A-350



Size	Weight(g)	ERD(mm)
700C(622-12)	585	576
650C(571-12)	540	526
24"x1(520-12)	489	475
20"x1 1/8(451-12)	430	405
20"(406-12)	380	360

Holes: 18H/20H/24H/28H/32H/36H
Option: GSW/CSW
Joint: Pinned

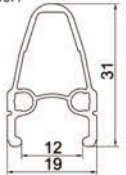

A-T300



Size	Weight(g)	ERD(mm)
700C(622-17)	601	577
Holes: 28H/32H		
Option:		
Joint: Pinned		

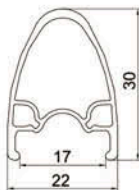

A-280



Size	Weight(g)	ERD(mm)
700C(622-15)	560	582
Holes: 20H/24H/28H/32H/36H		
Option:		
Joint: Pinned		

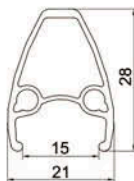

A-260



Size	Weight(g)	ERD(mm)
700C(622-13)	506	587
Holes: 20H/24H/28H/32H/36H		
Option:		
Joint: Pinned		

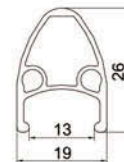

A-240



Size	Weight(g)	ERD(mm)
700C(622-15)	530	591
26"(559-15)	475	528

Holes: 28H/32H/36H
Option: Eyelets
Joint: Pinned



A-220



Size	Weight(g)	ERD(mm)
700C(622-15)	508	595
Holes: 20H/24H/28H/32H/36H		
Option: Eyelets/GSW/CSW		
Joint: Pinned		

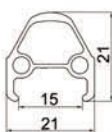

RC-200



Size	Weight(g)	ERD(mm)
700C(622-14)	520	600
Holes: 32H/36H		
Option: Eyelets/GSW/CSW		
Joint: Pinned		

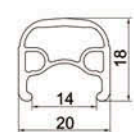

RR-300



Size	Weight(g)	ERD(mm)
700C(622-13)	400	596
650C(571-13)	374	546
20"x1 1/8(451-13)	291	425
18"(355-13)	235	333

Holes: 20H/24H/28H/32H/36H
Option: Eyelets/GSW/CSW
Joint: Sleeved

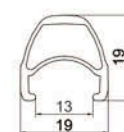

A-M8



Size	Weight(g)	ERD(mm)
700C(622-14)	510	602
650C(571-14)	475	552
24"x1(520-14)	426	501
20"x1 1/8(451-14)	370	431

Holes: 20H/24H/28H/32H/36H
Option: Eyelets/GSW/CSW
Joint: Pinned

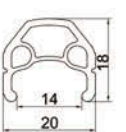

DB-X50



Size	Weight(g)	ERD(mm)
29"(622-45)	764	602
27.5"(584-45)	714	564
26"(559-45)	676	539

Holes: 32H/36H
Option:
Joint: Pinned

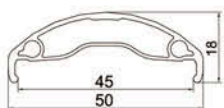

DB-X40



Size	Weight(g)	ERD(mm)
29"(622-35)	607	601
27.5"(584-35)	556	563
26"(559-35)	543	538

Holes: 32H/36H
Option:
Joint: Pinned

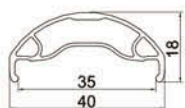

DB-X38



Size	Weight(g)	ERD(mm)
29"(622-38)	602	606
27.5"(584-38)	566	568
26"(559-38)	541	543

Holes: 32H/36H
Option:
Joint: Pinned

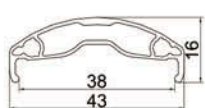

DB-42



Size	Weight(g)	ERD(mm)
26"(559-35)	762	539

Holes: 32H/36H
Option: GSW/CSW
Joint: Pinned

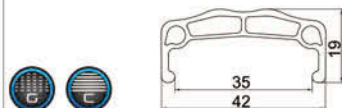

DB-32



Size	Weight(g)	ERD(mm)
26"(559-26)	603	529
20"(406-26)	439	375

Holes: 28H/32H/36H/48H
Option: Eyelets/GSW/CSW
Joint: Pinned



DB-31



Size	Weight(g)	ERD(mm)
29"(622-19)	514	594
27.5"(584-19)	484	556
26"(559-19)	462	531

Holes: 24H/28H/32H/36H
Option: Eyelets
Joint: Pinned



DB-30



Size	Weight(g)	ERD(mm)
700C(622-24)	553	600
27.5"(584-24)	516	563
26"(559-24)	495	538

Holes: 28H/32H/36H
Option: Eyelets
Joint: Pinned

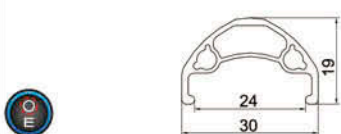

DB-T280



Size	Weight(g)	ERD(mm)
700C(622-19)	572	581

Holes: 28H/32H
Option: Eyelets
Joint: Pinned

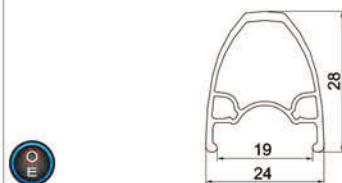

DB-25



Size	Weight(g)	ERD(mm)
700C(622-17)	513	602
27.5"(584-17)	482	563
26"(559-17)	462	540

Holes: 28H/32H/36H
Option: Eyelets
Joint: Pinned



DB-21



Size	Weight(g)	ERD(mm)
29"(622-21)	529	603
27.5"(584-21)	498	565
26"(559-21)	476	540

Holes: 24H/28H/32H/36H
Option: Eyelets
Joint: Pinned

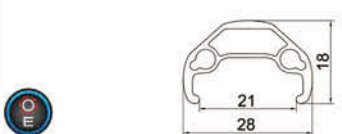

DB-19



Size	Weight(g)	ERD(mm)
700C(622-18)	500	600
26"(559-18)	450	540
24"(507-18)	408	488

Holes: 28H/32H/36H
Option: Eyelets
Joint: Pinned

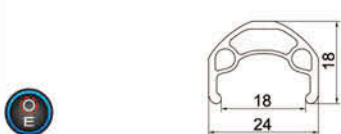

DB-18



Size	Weight(g)	ERD(mm)
29er/700C(622-19)	475	601
27.5"(584-19)	439	563
26"(559-19)	425	538
24"(507-19)	382	486

Holes: 28H/32H/36H
Option: Eyelets
Joint: Pinned





BX-38

Size	Weight(g)	ERD(mm)
26"(559-32)	725	544
24"(507-32)	660	492
20"(406-32)	530	390
16"(305-32)	405	290

Holes: 24H/32H/36H/48H
Option: Eyelets/GSW/CSW
Joint: Pinned

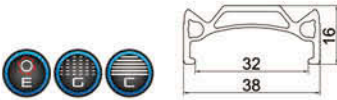

BX-36

Size	Weight(g)	ERD(mm)
20"(406-25)	690	372

Holes: 32H/36H/48H
Option: Eyelets/GSW/CSW
Joint: Pinned

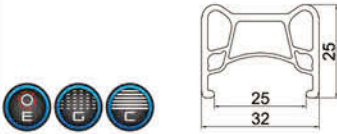

BX-34

Size	Weight(g)	ERD(mm)
26"(559-28)	572	540
20"(406-28)	417	386

Holes: 20H/28H/32H/36H/48H
Option: GSW
Joint: Pinned

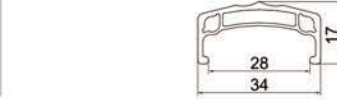

BX-32

Size	Weight(g)	ERD(mm)
700C(622-24)	588	606
27.5"(584-24)	555	569
26"(559-24)	530	544
24"(507-24)	480	492
20"(406-24)	385	390
16"(305-24)	290	290

Holes: 28H/32H/36H/48H
Option: Eyelets/GSW/CSW
Joint: Pinned



BX-28

Size	Weight(g)	ERD(mm)
26"(559-27)	664	540
20"(406-27)	484	386

Holes: 28H/32H/36H/48H
Option: Eyelets/GSW/CSW
Joint: Pinned



BX-25

Size	Weight(g)	ERD(mm)
20"(406-26)	403	389

Holes: 28H/32H/36H/48H
Option: GSW
Joint: Pinned



BX-24

Size	Weight(g)	ERD(mm)
20"(406-25)	441	390

Holes: 32H/36H/48H
Option: GSW
Joint: Welded



BX-16

Size	Weight(g)	ERD(mm)
20"(406-24)	445	390

Holes: 28H/32H/36H/48H
Option: Eyelets/GSW/CSW
Joint: Pinned



BX-14

Size	Weight(g)	ERD(mm)
24"(507-25)	462	492
22"(457-25)	417	442
20"(406-25)	370	390
16"(305-25)	280	290

Holes: 20H/28H/32H/36H/48H
Option: Eyelets/GSW/CSW
Joint: Pinned



SB-100

Size	Weight(g)	ERD(mm)
26"(559-94)	1170	536

Holes: 32H
Option: Eyelets/Reduce Weight Holes
Joint: Pinned

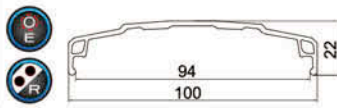

SB-90

Size	Weight(g)	ERD(mm)
26"(559-84)	918	535

Holes: 32H/36H
Option: Eyelets/Reduce Weight Holes
Joint: Pinned

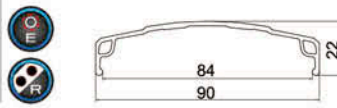

SB-80

Size	Weight(g)	ERD(mm)
26"(559-75)	900	536
24"(507-75)	880	484
20"(406-75)	710	383

Holes: 32H/36H
Option: Eyelets/Reduce Weight Holes
Joint: Pinned

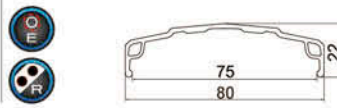



SB-60



Size	Weight(g)	ERD(mm)
24"(507-54)	549	488
20"(406-54)	476	387

Holes: 32H
Option: Reduce Weight Holes
Joint: Pinned

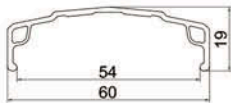

AS-T35



Size	Weight(g)	ERD(mm)
29"(622-35)	571	597
27.5"(584-35)	542	559

Holes: 32H
Option:
Joint: Sleeved

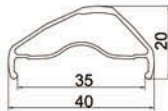

AS-30P



Size	Weight(g)	ERD(mm)
29"(622-30)	594	597
27.5"(584-30)	540	559

Holes: 32H
Option:
Joint: Pinned

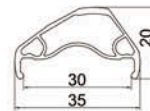

A-320

Size	Weight(g)	ERD(mm)
700C(622-19)	650	578
26"(559-19)	580	515
24"(507-19)	530	464
20"(406-19)	425	362

Holes: 28H/32H/36H
Option: GSW/CSW
Joint: Pinned

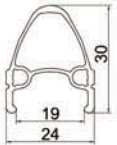

A-262



Size	Weight(g)	ERD(mm)
700C(622-17)	589	585

Holes: 20H/24H/28H/32H/36H
Option: GSW/CSW
Joint: Pinned

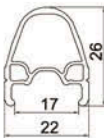

AS-210-P



Size	Weight(g)	ERD(mm)
700C(622-20)	482	595

Holes: 32H
Option:
Joint: Pinned

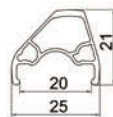

A-M6

Size	Weight(g)	ERD(mm)
700C(622-16)	530	596
26"(559-16)	475	534
24"(507-16)	430	482
20"x1 1/8(451-16)	385	425
20"(406-16)	345	380
16"x1 3/8(349-16)	305	325
16"(305-16)	301	282

Holes: 14H/20H/21H/24H/28H/32H/36H
Option: GSW/CSW
Joint: Pinned



A-M5

Size	Weight(g)	ERD(mm)
700C(622-14)	495	594
24"x1 3/8(540-14)	422	512
20"x1 1/8(451-14)	360	421

Holes: 20H/24H/28H/32H/36H
Option: GSW/CSW
Joint: Pinned

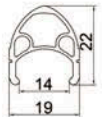

A-M4

Size	Weight(g)	ERD(mm)
29er/700C(622-19)	545	596
26"(559-19)	495	534
24"(507-19)	445	482
20"(406-19)	360	380

Holes: 20H/24H/28H/32H/36H
Option: Eyelets/GSW/CSW
Joint: Pinned

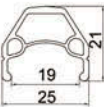

MT-96

Size	Weight(g)	ERD(mm)
700C(622-17)	515	602
26"x1 3/8(590-17)	490	571
26"(559-17)	465	540
24"(507-17)	420	488
20"x1 3/8(451-17)	374	431
20"(406-17)	340	386
18"(355-17)	300	335
17"x1 1/4(369-17)	303	350
16"x1 3/8(349-17)	295	330
16"(305-17)	255	286

Holes: 20H/24H/28H/32H/36H
Option: Eyelets/GSW/CSW
Joint: Pinned

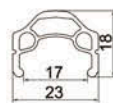

MT-86

Size	Weight(g)	ERD(mm)
700C(622-16)	490	600
26"(559-16)	440	538
20"(406-16)	325	384

Holes: 20H/24H/28H/32H/36H
Option: Eyelets/GSW/CSW
Joint: Pinned

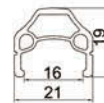

MT-46

Size	Weight(g)	ERD(mm)
28"(635-18)	537	616
29er/700C(622-18)	520	602
27.5"(584-18)	485	565
26"(559-18)	465	540
24"x1(520-18)	437	501
24"(507-18)	425	488
20"(406-18)	340	386

Holes: 20H/24H/28H/32H/36H
Option: Eyelets/GSW/CSW
Joint: Pinned

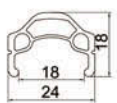



MT-26

Size	Weight(g)	ERD(mm)
700C(622-18)	515	608
26"(559-18)	465	546
24"(507-18)	420	494
20"(406-18)	335	392

Holes: 20H/24H/28H/32H/36H
Option: Eyelets/GSW/CSW
Joint: Pinned



MT-20

Size	Weight(g)	ERD(mm)
700C(622-17)	520	602
27.5"(584-17)	490	564
26"(559-17)	465	540
24"(507-17)	425	488
20"(406-17)	340	386

Holes: 20H/24H/28H/32H/36H
Option: Eyelets/GSW/CSW
Joint: Pinned



CT-46

Size	Weight(g)	ERD(mm)
28"(635-18)	494	616
29er/700C(622-18)	487	603
27.5"(584-18)	459	565
26"(559-18)	438	540
24"x1(520-18)	406	501
24"(507-18)	399	488
20"(406-18)	321	387

Holes: 20H/24H/28H/32H/36H
Option: Eyelets/GSW/CSW
Joint: Pinned

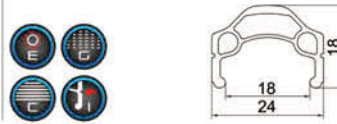

MP-50

Size	
700C(622-45)	26"(559-45)
27.5"(584-45)	24"(507-45)

Holes: 32H/36H
Option: GSW
Joint: Pinned

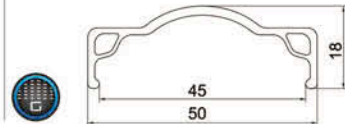

MP-32

Size	
26"(559-26)	24"(507-26)

Holes: 32H/36H
Option: GSW
Joint: Pinned

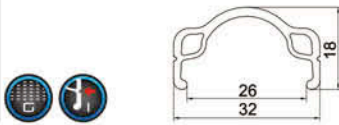

MP-22

Size	
26"(559-23)	24"(507-23)

Holes: 32H/36H
Option: GSW
Joint: Pinned

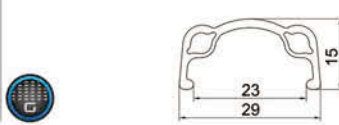

A-7N

Size	
700C(622-20)	26"(559-20)

Holes: 32H/36H
Option: GSW
Joint: Pinned

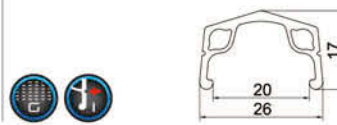

A-6N

Size	
26"(559-21)	18"(355-21)
24"(507-21)	16"(305-21)
22"(457-21)	14"(254-21)
20"(406-21)	12"(203-21)

Holes: 20H/24H/28H/36H
Option: GSW
Joint: Pinned

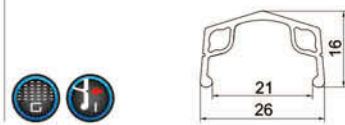

A-5N

Size	
26"x1 3/8(590-21)	18"(355-21)
26"(559-21)	16"(305-21)
24"(507-21)	14"(254-21)
22"(457-21)	12"(203-21)
20"(406-21)	

Holes: 20H/24H/28H/36H
Option: GSW
Joint: Pinned

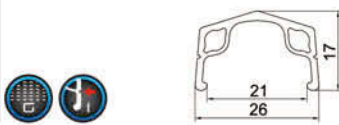

A-7X

Size	
26"(559-26)	20"(406-26)
24"(507-26)	18"(355-26)
22"(457-26)	16"(305-26)

Holes: 20H/24H/28H/32H/36H/48H
Option: Eyelets/GSW/Dimple
Joint: Pinned

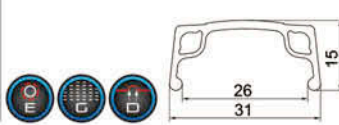

A-5X

Size	
700C(622-19)	20"(406-19)
26"(559-19)	18"(355-19)
24"(507-19)	16"(305-19)

Holes: 20H/24H/28H/32H/36H
Option: Eyelets/GSW/CSW
Joint: Pinned

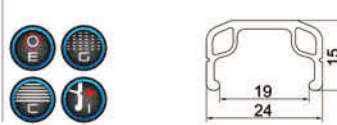

LP-60

Size	
27"x1 1/4(630-20)	22"x1 3/8(490-20)
26"x1 3/8(590-20)	20"x1 3/8(451-20)
24"x1 3/8(540-20)	18"x1 3/8(400-20)

Holes: 20H/24H/28H/32H/36H
Option: GSW
Joint: Pinned

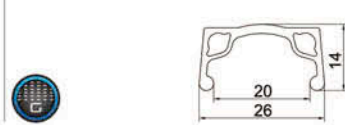



Saint Jump
Wheel Crafters

Hand build wheel with **PASSION**, and
Always in good form with **BEST SERVICE.**

TENY WHEEL

FOR STRONGER WHEEL & FASHION SHAPE

CARGO BIKE

NEW
VISION!



6 ADVANTAGES OF TENY WHEEL

- Wheel has high strength, it could be loaded 200 KGS
- Fashion shape to catch people's eyes
- No rust problem even after the rainy day
- More colors are available and to choose
- No need to use rim tape
- Acquired ISO 4210 testing certification



TENY RIM ENTERPRISE CO., LTD. 田霖企業股份有限公司

Tel: +886-6-2539738 Fax: +886-6-2539688 E-mail: T8634081@ms38.hinet.net Master@weitt-teny.com

No. 30, Lane 32, Chungcheng 1st St., Yung kang Dist., Tainan City, Taiwan



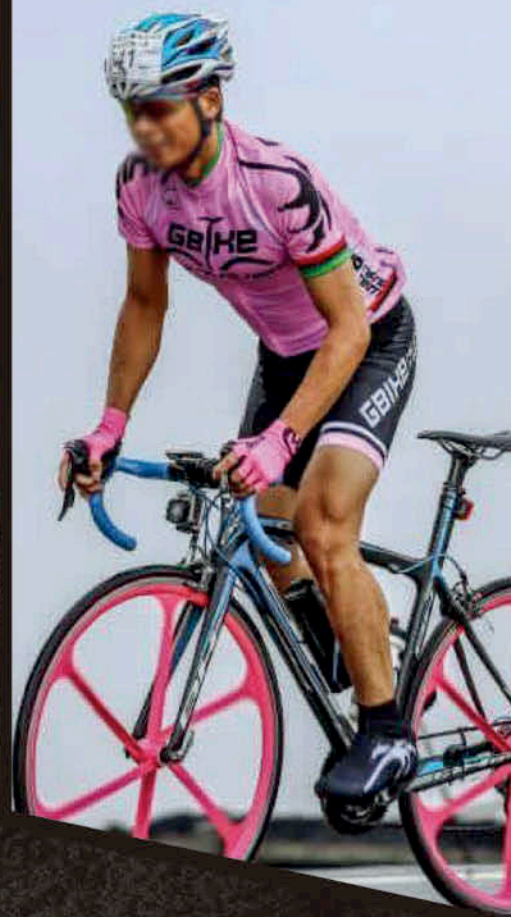

TENNY
RIM

TRAINING & TOUR FOR SPEED

TNR aeromechanics wheelset is good weapon which helps a player make training for triathlon competition, it has below advantages than regular spoke wheel.

1. Raises muscular endurance of thigh and leg - when a player rides uphill path, he must use more power to climb, times of riding and training, explosive force of muscle would be strengthen, when he use lighter wheelset in competition, he would feel his legs are lighter and easy to set all power free.

2. Strengthens vital capacity - When use this wheelset on training, player needs to spend more energy to finish all schedule, as time passes, vital capacity raised because of heavy training. When in the formal competition, player has huge advantage than others, not easy to feel tired and full of energy to do final sprint.

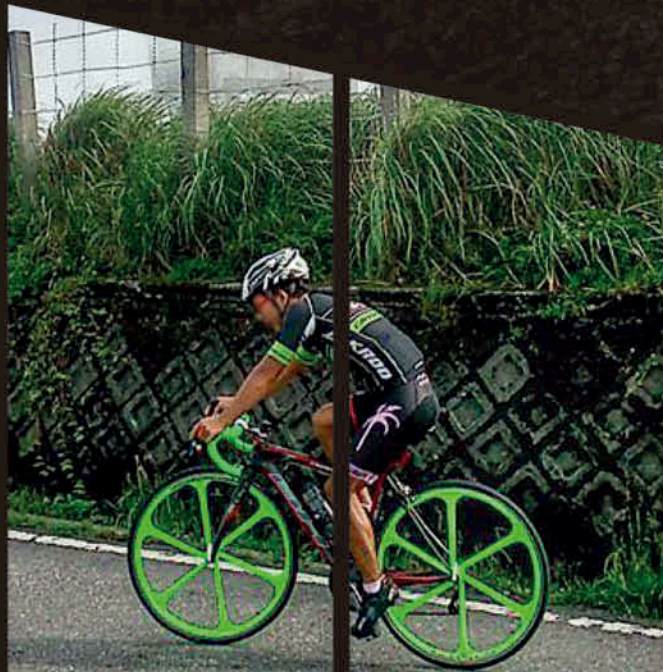

襪帶OEM製造 成品印刷 襪帶包裝 交期迅速 低MOQ

RIM TAPE Manufacturer

Made in Taiwan



RIM TAPE PRINTING

SMALL PACKAGE

Rim Tape Material 襪帶材質:

PVC: 0.4mm / 0.55mm / 0.65m

Nylon+PVC: 120psi / 145psi

In-house Developed Machines
自行研發機器

Completed Production Process
完整的製造流程

Automated Production Line
自動化生產



RIM TAPE with YOUR LOGO

Single-colour Printing 單色印刷
Multi-colour Printing 多色印刷

Tech Specification 產品規格

Length 尺寸	12" 14" 16" 18" 20" 24" 26" 28"
	650A 650B 650C 700C
Width 寬度	12mm~100mm
Hole 孔徑	A/V, F/V
Material 材質	Nylon + P.V.C. , P.V.C.
Others 其他	Customized Products 客製化產品

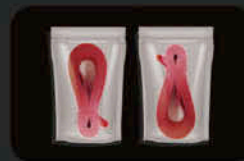

Zipper Bag



Box



Shrink Wrap
Rubber Band

鑠兆國際股份有限公司

Taichung, Taiwan

TEL 04-2317-8433 FAX 04-2317-8435 Mobile 0921-357-550 contact@strimtape.com



玉鉉

**YUH SHIUANN
INDUSTRIES CO.,LTD**

Add:NO.41-1 SHILIAU LN.,YUAN-LU
RD.,CHIHU CHEN,CHANGHUA,
TAIWAN.
Tel:886-4-8612997 Fax:886-4-8819941
E-mail:yuh.shiuann@msa.hinet.net
E-mail:unicycle@unicyce.com.tw
http://www.unicycle.com.tw



Mode HE-1(7A)

Steel,C-p or ED finish
Size: 12"x1.75~2.125
14"x1.75~2.125
16"x1.75~2.125
18"x1.75~2.125
20"x1.75~2.125
24"x1.75~2.125
26"x1.75~2.125



Model HE-2

Steel,C-p or ED finish
Size: 20"x2.125
24"x2.125
26"x2.125
36"x2.125



Model HE-3(7c)

Steel,C-p or ED finish
Size: 16"x1.75~2.125
18"x1.75~2.125
20"x1.75~2.125
24"x1.75~2.125
26"x1.75~2.125

**WE ARE SPECIALIZED IN
MANUFACTURING STEEL RIMS**



**Moedi HE-7X
(NON-Dimple)**

Steel,C-p or ED finish
16"x1.75~2.125
20"x1.75~2.125
24"x1.75~2.125
26"x1.75~2.125



**Moedi HE-7X
(Dimple)**

Steel,C-p or ED finish
16"x1.75~2.125
20"x1.75~2.125
24"x1.75~2.125
26"x1.75~2.125



Chopper

Steel,C-p or golden finish
16"x52Hor68H
20"x68Hor140H
24"x68Hor140H
26"x68Hor140H



Motorcycle

Spe.:1.85,1.6,1.40,1.20
size:14",15",16",17",18",
19",21"

E-MTB

TUBELESS READY

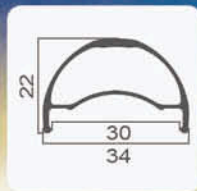
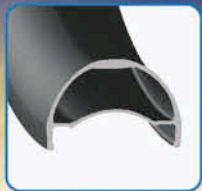

Model:GE30



Size:27.5"PLUS

Material:6061

Joint:Welded/Sleeved

Finish:Black anodized

Weight:550g

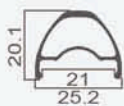

Model:GE21

Size:27.5"PLUS

Material:6061

Joint:Sleeved

Finish:Black anodized

Weight:420g

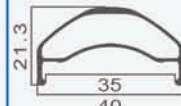
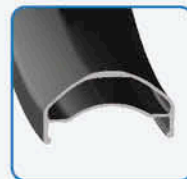

Model:GE35

Size:27.5"PLUS

Material:6061

Joint:Sleeved

Finish:Black anodized

Weight:590g

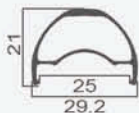

Model:GE25

Size:27.5"(584×25)

Material:6061

Joint:Sleeved

Finish:Black anodized

Weight:490g

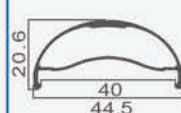

Model:FM40

Size:27.5"PLUS

Material:6061

Joint:Welded

Finish:Black anodized

Weight:625g

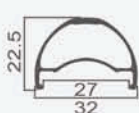

Model:GE27

Size:27.5"(584×27)

Material:6061

Joint:Sleeved

Finish:Black anodized

Weight:530g

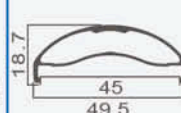

Model:FM45

Size:27.5"PLUS

Material:6061

Joint:Welded

Finish:Black anodized

Weight:690g



司浦特 複合材料科技有限公司

SPRINT COMPOSITE TECHNOLOGY LTD.

中國東莞廠 廣東省東莞市塘廈鎮四村管理區楊梅苑19號中品產業園A2棟101 TEL:+86 769 8847 1688
台北辦事處 新北市新店區寶元路一段87巷1號7樓 TEL : + 886 2 2913 6953

C02

CARBON RIM

創新技術

產品優勢

www.sprintrims.com
info@sprintrims.com

司浦特在複合材料深耕超過20年，多年來專注材料與工藝精進，歷經六年研發出領先全球，高度自動化碳纖維輪圈的製程技術，徹底改變了複合材料界對碳纖維輪圈的製造印象，成功將傳統手工製造容易形成的不穩定因素排除。

全新自動化製程除了比傳統手工貼料在品質上更穩定、結構更對稱及無斷點拼接之外，直接也大幅降低了生產成本。

廠內測試設備齊全，測試標準皆遵循國際知名品牌標準為依據，ISO及EN皆可達標。

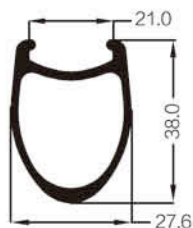

700C 3827U Clincher

Rim Depth: 38mm Rim Width: 27mm
Weight: 420g±10g SuperLight: 385±10g
Brake Type: Disc Brake & Caliper Brake
Finish: UD/Matt/Clear

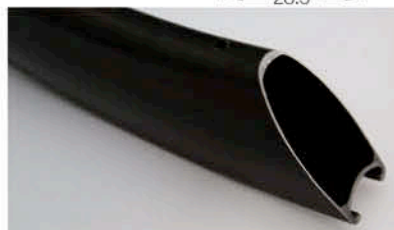
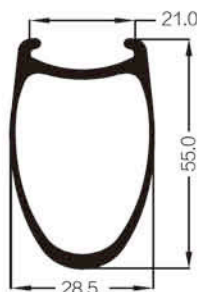

700C 5527U Clincher

Rim Depth: 55mm Rim Width: 27mm
Weight: 495g±10g
Brake Type: Disc Brake & Caliper Brake
Finish: UD/Matt/Clear

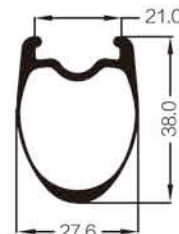

700C 3827T Tubeless

Rim Depth: 38mm Rim Width: 27mm
Weight: 420g±10g SuperLight: 385±10g
Brake Type: Disc Brake & Caliper Brake
Finish: UD/Matt/Clear

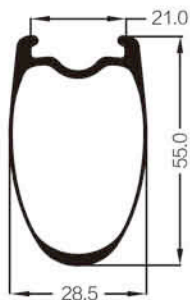

700C 5527T Tubeless

Rim Depth: 55mm Rim Width: 27mm
Weight: 495g±10g
Brake Type: Disc Brake & Caliper Brake
Finish: UD/Matt/Clear



700C 3825U Clincher

Rim Depth: 38mm Rim Width: 25mm
Weight: 385g±10g SuperLight: 365±10g
Brake Type: Disc Brake & Caliper Brake
Finish: UD/Matt/Clear

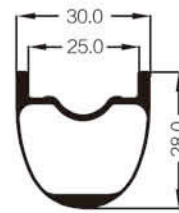

MTB 29" 2830H Hookless

Rim Depth: 28mm Rim Width: 30mm
Brake Type: Disc Brake
Finish: UD/Matt/Clear

RIM



Elite Aero

700C Wide Aero Carbon Clincher Rim

Item No. 032CW/042CW
Profile 32/42mm
Weight 465/475 ± 25g
Internal Width 21mm
Finish UD or 3K, Matt or Clear



Elite Tubeless

700C Wide Carbon Tubeless Ready Clincher Rim

Item No. 038CWT/050CWT/065CWT/088CWT
Profile 38/50/65/88mm
Weight 484/522/563/695g ± 25g
Internal Width 19mm
Finish UD or 3K, Matt or Clear

Disc Specific Version Available



Elite Tubeless - AWR Process

Item No. 038CWT-A
050CWT-A
065CWT-A
088CWT-A
Weight 440/458/522/633g ± 25g
Finish Blacken, Matt or Clear



◀ Hookless

Lightweight Disc

700C Wide Carbon Hookless / Hooked Disc Specific Clincher Rim

Item No. 030CHD / 040CHD/ 050CHD
Profile 30/40/50mm
Internal Width 19.4mm
Weight 373/416/449g ± 20g(Hookless)
399/441/477g ± 20g(Hooked)
Finish Blacken, Matt or Clear



MTB Hookless

27.5/29" XC Carbon Clincher Tubeless Ready (Disc Brake)

Item No. 722CT/922CT
Height 22mm
Weight 350/365g ± 20g
Internal Width 24mm
Finish Blacken UD, Matt or Clear

27.5/29" AM Carbon Clincher - Tubeless Ready (Disc Brake)

Item No. 729CT/929CT
Height 29mm
Weight 480/495g ± 20g
Internal Width 34.5mm
Finish Blacken, Matt or Clear



MTB Asymmetric

29/27.5" MTB Asymmetric Hookless Clincher Tubeless Ready (Disc Brake)

Item No. 925CAT/ 725CAT
Height 25mm
Offset 3mm
Weight 415/450g ± 25g
Internal Width 28mm
Finish UD or 3K, Matt or Clear



LOOKING FOR ALL WIDTH RANGE TUBELESS RIM?

WEINMANN OFFER RIM FOR TIRE 1.95" TO 3.0"

SATISFY YOUR NEED

NEW!

TUBELESS
(WELDING)



QX32 TL

29"X32C-42C (491克)
27.5"x2.20-2.35 (462克)
26"x2.20-2.35 (440克)

TUBELESS
(WELDING)



QX38 TL

700CX23C~28C (580克)

TUBELESS



U28 TL

29"X28C-38C (462克)
27.5"X2.20 (435克)
26"X2.20 (413克)

TUBELESS



U40 TL

29"X35C-42C (646克)
27.5"x2.2-2.8 (608克)
26"x2.2-2.8 (579克)

WEINMANN
HUIZHOU . CHINA
www.weinmanntek.com
sales@weinmanntek.com

WE CAN DO WHATEVER YOU NEED BY ECO-FRIENDLY MATERIAL

RIM TAPE

SECURITY & PROMOTE

JN/
JNU



NYLON

lightweight / durable / resisticle
thickness:0.5mm

JNA



NYLON with sticker

classic touch fastening / durable
easy to use
thickness:0.4mm

SHOW YOUR LOGO

Can be a little amount
to make sample !!



STICKER NYLON RIM TAPE

All sizes available as to customer's order

JP/
JPH



JP / PVC

flexible
thickness:0.6mm

JPH / PVC

All-weather performance / high flexible / high tensile
thickness:0.7mm / 1mm

JUH



TPU Eco-friendly material

thickness:0.7mm/0.9mm

JM

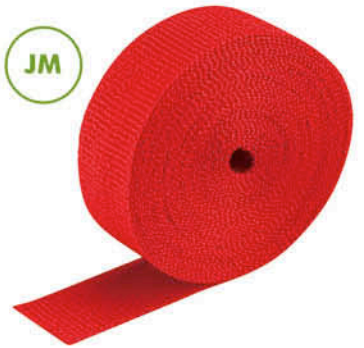

COTTON with sticker

Perfectly fit / easy to use
thickness:0.65mm

PUNCTURE-PROOF

JU



TPU Eco-friendly material

Temperature range:-20°C
thickness:0.8mm

JW



PVC Jet

Used between tires and inner tubes,
Puncture resistant.
Temperature range:-15°C ~ 14°C
thickness:1.2mm

Why Choose JOGON?

JOGON rim tape

traditional rim tape



V.S

UNDER THE SAME CONDITIONS
PASS THE SAME TIME

- Not easy to be cracked
- High Pressure Resistant
- High Temperature Resistant



JOGON INDUSTRIES CO.,LTD.
JOGON.COM.TW

TAIWAN

+886-37-756558 ☎ +886-37-750836
✉ NINE@JOGON-PAK.COM
🏠 No.8-9, PingYuan, TongXiao Town Miaoli County, Taiwan

• Compatible with dropouts. • Silica gel development, Welcome calling for cooperative development. / どうぞお気軽にお問い合わせ下さい

KUNSHAN CHINA

☎ 86-512-57617899
☎ 86-512-55160169
✉ KS@JOGON.COM.CN

SHENZHEN CHINA

☎ 86-755-81735109
☎ 86-755-81735185
✉ SZ@JOGON.COM.CN

RIM TAPE

SECURITY & PROMOTE

TUBELESS TAPE



PP Composition

thickness:0.12mm

PE Composition

thickness:0.12mm

PACKAGE



SPECIFICATION FORM

	JN	JNU	JNA	JP	JPH	JUH	JE	JW	JU	JKC	JKD
Material	Nylon W/PVC	Nylon W/TPU	Nylon with sticker	PVC	PVC High Tensility	TPU	PVC Jet	PVC Jet	TPU (Environmental)	PP Composition	PE Composition
Rim	12" - 28"	12" - 28"	Customized sizes available	12" - 28"	12" - 28"	12" - 28"	12" - 28"	Customized sizes available	Customized sizes available	10M 20M / 50M	10M 20M / 50M
Wide	11 - 100mm	11 - 100mm	Customized sizes available	11 - 100mm	11 - 100mm	11 - 100mm	11 - 100mm	25 - 52mm	25 - 52mm	Customized sizes available	Customized sizes available
Thick	0.5mm/0.8mm	0.5mm	0.4mm	0.6mm	0.7mm / 1mm	0.7mm/0.9mm	0.4mm	1.2mm	0.8mm	0.12mm	0.12mm

★ Passed non-toxic materials standards. ★ All sizes available as to customer's order / available for all kinds of bike whiil rims.

ORDERING INFO | ITEM NO. = Model + Rim + Wide + Thick + Color
EXAMPLE | JPH261407 = JPH 26 14 07 Y

VARIOUS MATERIAL FOR YOUR CHOICES

WELCOME YOU TO CALL FOR COOPERATIVE DEVELOPMENT





AUTO ASSEMBLY LINE FOR TUBELESS EYELET SYSTEM

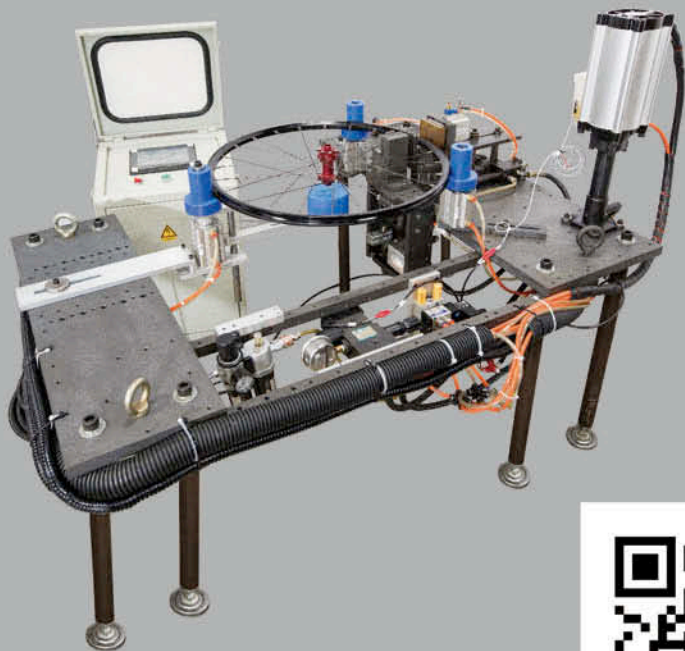

PATENT

US 12/799,307
EU 11159632.OCT
Taiwan I 280926
Taiwan I 401168

Easy Repair



Hand tool repair

Advantage:

- 1 Spoke can whirling 15°.
- 2 No shear generated.
- 3 No tapes.
- 4 No external holes.
- 5 For High and Low rims.
- 6 Repair without remove wheels.
- 7 Available for self-replace.
- 8 For both carbon and aluminum rims.
- 9 Auto-machine assembly.

優點

- 1 輪輻可環狀偏擺15°
- 2 無剪力產生
- 3 無浪帶帶
- 4 無材料外傷孔
- 5 高、低框適用
- 6 免拆輪維修
- 7 可用工具自行維修及換胎
- 8 適用破塊及鈣框
- 9 自動化組立

Ventaja

- 1 Anillos para rayos con ángulos hasta 15°.
- 2 Fabricados sin cortes.
- 3 Sin cintas.
- 4 Sin agujeros externos.
- 5 Disponibles para uso en aros altos y bajos.
- 6 Reparables sin remover las llantas.
- 7 Disponibles para reemplazarlos.
- 8 Compatible con aros de aluminio y fibra de carbon.
- 9 Auto-ensamble con maquina.

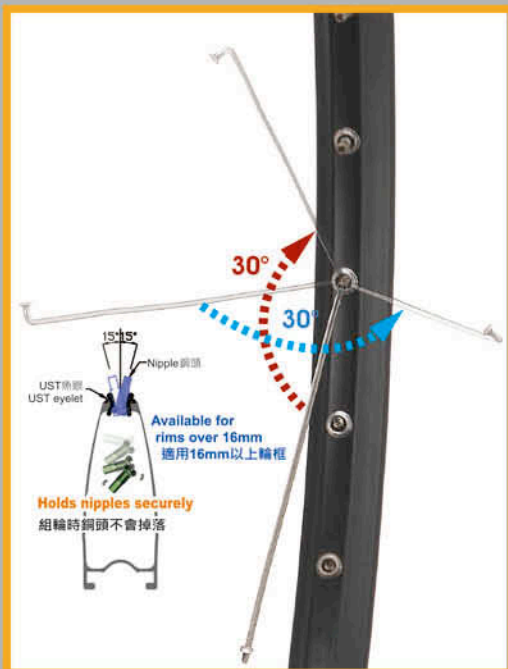

Vorteil

- 1 +/- 15° Speicherwinkel
- 2 Keine Kerbkräfte von Speichennippeln auf dem Felgenprofil
- 3 Kein Felgenband mehr notwendig
- 4 Keine Bohrungen im Felgenbett
- 5 Für Nieder- und Hochprofilfelgen
- 6 Sehr reparaturfreundlich
- 7 Austausch der Eyelets und Speichennippel erhältlich
- 8 Auf Aluminium- und Carbonfelgen einsetzbar
- 9 Felgen können problemlos auf vollautomatischen Einspeichmaschinen aufgebaut werden

Little Pins Create Great Wonders



U.S. patent No. 5470133



Specialized in making eyelets

TAIWAN:

MING CHUAN CORP.

Tel: 886-4-7612336 Fax: 886-4-7628883

E-mail: ho-milin@umail.hinet.net

CHIHA:

ZIV INT'L CO., LTD.

E-mail : lifuxp@vip.163.com

Tel:86-769-87682228 Fax: 86-769-87682223

Rim Eyelet

Patented in Many Countries

Double-layered Eyelet
Specifically for E-bike.

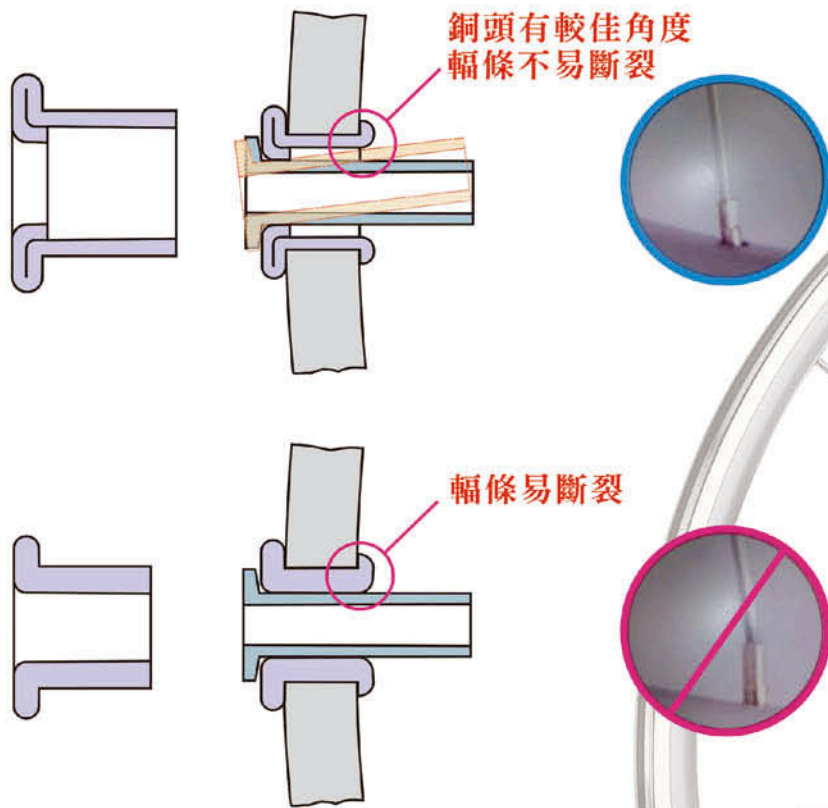

Rims equipped with the eyelets are easy to
spoke and the spoke has a better free angle
to find its direction from the rim to the hub.



Special Pin for automatic
rim joining machine.



PEGASUS METAL CO., LTD.

109, Jianguo N. Road, Changhua 500, Taiwan

E-mail: pegasus.metal@msa.hinet.net

Tel: 886-4-7366207 Fax: 886-4-7366208

www.pegasusmetal.com

All New Product

TAPE FOR TIRE & TUBE

We welcome overseas representatives to work with us opening up new markets.

Please contact us by fax.



Tape For Tire & Tube

1950 x 38mm

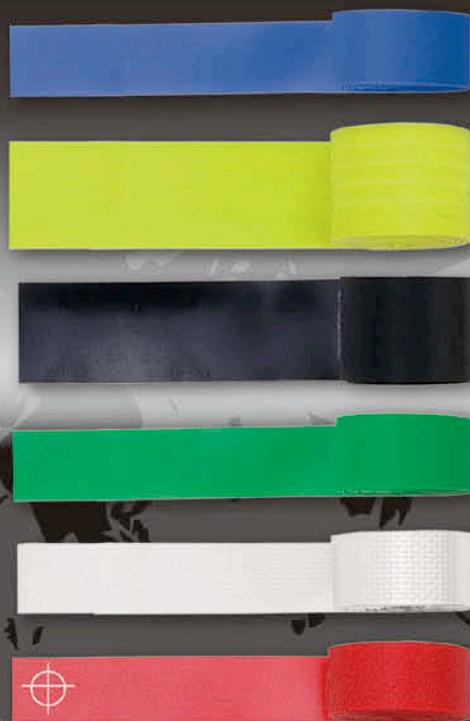

Show Your Logo

O.B.RIM

商品規格表

Specification

Model	Name	Rim Type	Wide	Thick	PSI	Remark
RJ-B (PVC)	一般型襯帶 (適用於單層圈)	12"~28"	14mm~80mm	0.55/0.65mm	80	O.E.M package D.I.Y package
RJ-A (NYLON)	耐用型襯帶 (適用於雙層圈)	12"~28"	14mm~100mm	0.5mm	120	O.E.M package D.I.Y package
RJ-AS (NYLON)	超耐用型襯帶	12"~28"	14mm~100mm	0.5mm	150	O.E.M package D.I.Y package

ITEM Number = Model + Rim + Wide + Thick
EX: RJA121404=Rja + 12 + 14 + 0.4

DIY 商品包裝樣式 Packaging



熱收縮膜
Heat shrink film



勸環企業有限公司

RUI JING INDUSTRIAL CO., LTD.

彰化縣永靖鄉瑚璉村錫壽路48號

No. 48, Xishou Rd., Yongjing Township, Hu Lian Village, Changhua County 512, Taiwan

Tel: 886-4-8243199

Fax: 886-4-8234007

E-mail: r6111@ms76.hinet.net

Mobile: 0919-009838

ADK TECHNOLOGY LIMITED
<http://www.adktec.com>

E-mail: kenneth@adktec.com / alex@adktec.com Contact: Kenneth Yen / Alex Chen
 No.792, Sec. 2, Taiwan Blvd., Xitun Dist., Taichung City 407, Taiwan Tel:886-4-36069630 Fax:886-4-36069633



MODEL:STRI01-WH(F/R)

700C Carbon Clincher rim
 Deep profile 60mm
 UDM Finish
 700C 20/24 holes
 O.L.D(F/R)-100mm/130mm
 Alloy Hub 6061-T6,SB or
 Shimano,SRAM,Campagnolo
 Spoke 14G stainless

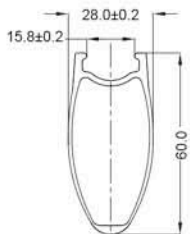

MODEL:STRI02-WH(F/R)

700C Carbon Clincher rim
 Deep profile 44mm
 UDM Finish
 700C 20/24 holes
 O.L.D(F/R)-100mm/130mm
 Alloy Hub 6061-T6,SB or
 Shimano,SRAM,Campagnolo
 Spoke 14G stainless

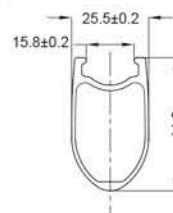

MODEL:AKRI16-WH(F/R)

700C Carbon Tubular rim
 Deep profile 38mm
 UDM Finish
 700C 20/24 holes
 O.L.D(F/R)-100mm/130mm
 Alloy Hub 6061-T6,SB or
 Shimano,SRAM,Campagnolo
 Spoke 14G stainless

DISC Available

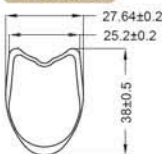

MODEL:AKRI17-WH(F/R)

700C Carbon Tubular rim
 Deep profile 55mm
 UDM Finish
 700C 20/24 holes
 O.L.D(F/R)-100mm/130mm
 Alloy Hub 6061-T6,SB or
 Shimano,SRAM,Campagnolo
 Spoke 14G stainless

DISC Available

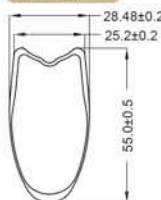

MODEL:AKRI18-WH(F/R)

700C Carbon Tubular rim
 Deep profile 88mm
 UDM Finish
 700C 20/24 holes
 O.L.D(F/R)-100mm/130mm
 Alloy Hub 6061-T6,SB or
 Shimano,SRAM,Campagnolo
 Spoke 14G stainless

DISC Available

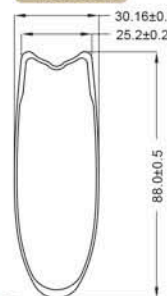

MODEL:AKRI20-WH(F/R)-Hookless

MTB 27.5+ Plus Carbon Tubeless Ready rim
 Deep profile 23mm
 UDM Finish
 MTB 27.5+28/28 holes
 O.L.D(F/R)-100mm/ 130mm
 Alloy Hub 6061-T6, SB or
 Shimano,SRAM, Campagnolo
 Spoke 14 stainless

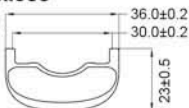

MODEL:AKRI21-WH(F/R)

MTB 27.5" Carbon Tubeless Ready rim
 Deep profile 28mm
 UDM Finish
 MTB 27.5" 28/28 holes
 O.L.D(F/R)-15x100mm/ 12x142mm
 Alloy Hub 6061-T6
 Shimano,SRAM FH available
 Spoke 14G/15G stainless

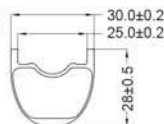

MODEL:AKRI22-WH(F/R)

MTB 29" Carbon Tubeless Ready rim
 Deep profile 28mm
 UDM Finish
 MTB 29" 28/28 holes
 O.L.D(F/R)-15x100mm/ 12x142mm
 Alloy Hub 6061-T6
 Shimano,SRAM FH available
 Spoke 14G/15G stainless

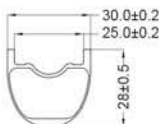

DISC
version

Model: AKRI24-D-WH(F/R)

700C Carbon Tubeless Ready rim
 Deep profile 38mm
 UDM Finish
 700C 28/28 holes
 O.L.D(F/R)-100mm/135 or 142mm
 Alloy Hub 6061-T6
 Shimano, SRAM, Campagnolo FH available
 Spoke 14G stainless

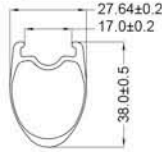

DISC
version

Model: AKRI25-D-WH(F/R)

700C Carbon Tubeless Ready rim
 Deep profile 55mm
 UDM Finish
 700C 28/28 holes
 O.L.D(F/R)-100mm/135 or 142mm
 Alloy Hub 6061-T6
 Shimano, SRAM, Campagnolo FH available
 Spoke 14G stainless

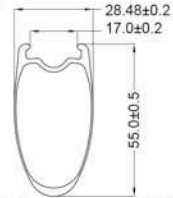

MODEL: AKRI24-WH(F/R)

700C Carbon Tubeless Ready rim
 Deep profile 38mm
 UDM Finish
 700C 20/24 holes
 O.L.D(F/R)-100mm/135 or 142mm
 Alloy Hub 6061-T6
 Shimano, SRAM, Campagnolo FH available
 Spoke 14G stainless

RIM
version

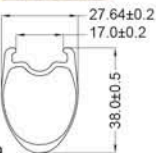

MODEL: AKRI25-WH(F/R)

700C Carbon Tubeless Ready rim
 Deep profile 55mm
 UDM Finish
 700C 20/24 holes
 O.L.D(F/R)-100mm/135 or 142mm
 Alloy Hub 6061-T6
 Shimano, SRAM, Campagnolo FH available
 Spoke 14G stainless

RIM
version

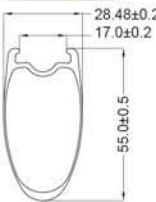

MODEL: AKRI26-WH(F/R)

700C Carbon Tubeless Ready rim
 Deep profile 88mm
 UDM Finish
 700C 20/24 holes
 O.L.D(F/R)-100mm/130mm
 Alloy Hub 6061-T6
 Shimano, SRAM, Campagnolo FH available
 Spoke 14G stainless

DISC
Available

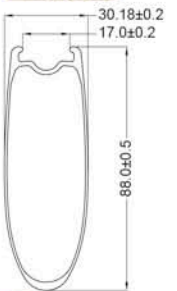

MODEL: AKRI13-WH(F/R)

700C Carbon Clincher rim
 Deep profile 38mm
 UDM Finish
 700C 20/24 holes
 O.L.D(F/R)-100mm/130mm
 Alloy Hub 6061-T6, SB or
 Shimano, SRAM, Campagnolo
 Spoke 14G stainless

DISC
Available

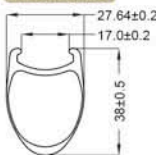

MODEL: AKRI14-WH(F/R)

700C Carbon Clincher rim
 Deep profile 55mm
 UDM Finish
 700C 20/24 holes
 O.L.D(F/R)-100mm/130mm
 Alloy Hub 6061-T6, SB or
 Shimano, SRAM, Campagnolo
 Spoke 14G stainless

DISC
Available

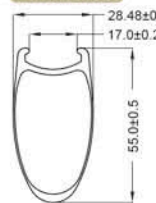

MODEL: AKRI15-WH(F/R)

700C Carbon Clincher rim
 Deep profile 88mm
 UDM Finish
 700C 20/24 holes
 O.L.D(F/R)-100mm/130mm
 Alloy Hub 6061-T6, SB or
 Shimano, SRAM, Campagnolo
 Spoke 14G stainless

DISC
Available

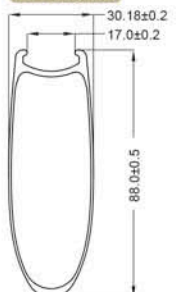

RUBAR[®]



SHADOW ASURA 50

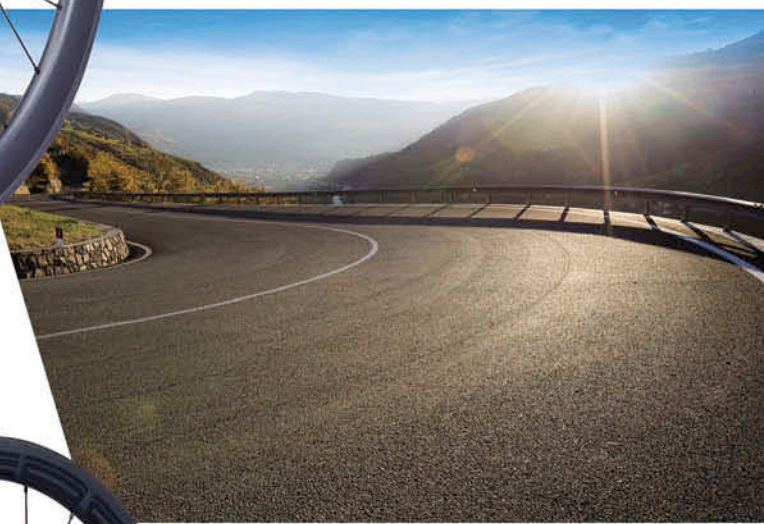

SHADOW ASURA 38



ACHIMAY ENTERPRISE CO.,LTD.

TEL:886-4-24633258 FAX:886-4-24629911

E-mail:achimay.tw@msa.hinet.net

No. 486-8, Fuya Rd., Xitun Dist., Taichung City 407,
Taiwan



張力釋放



手工組立輪組



應力釋放



偏擺值完全校正



歐盟國際標準
測試通過



▲ BWC-139LP
700C racing Carbon/alloy
clincher rim 55mm



▲ BWC-124-Disc
50mm full carbon clincher rim,
disc hub, 11 speed for road



▲ BWR-111
700C racing/track full carbon
tubular disc wheel (rear only)



▲ BWR-130
30mm full carbon tubular
rim, 29er, width: 24.8mm

▲ BWR-132
650B clincher rim
28mm

▲ BWR-133
29er clincher rim
30mm



▶ BCW-5002
Carbon credit
card wallet



▶ BCW-5003
Big wallet for paper money,
credit card w/coin pocket



▶ BCW-0017
carbon wallet
L95*W120*H20mm



New
▶ BCW-0022
carbon big wallet
L100*W190*H20mm



New
▶ BCW-0026
carbon hand bag size
20*10.5*2.5cm



▲ BWT-H
Valve extension tool



▲ BQR-013
Carbon lever, ti-axle at 42g/set, for MTB: BQR-018



▲ BQR-020
Through axle QR,
front 15mm, rear 12mm



▲ BQR-023
Through axle with bolt type,
front 15mm, rear 12mm

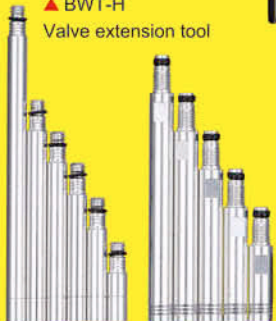

▲ BWT-Valve-T
In 25mm, 38mm,
50mm, 60mm,
70mm, 100mm



▲ BWT-Valve-H
30mm, 40mm,
50mm, 60mm,
70mm



▲ BWT-Valve-L
tubeless Valve stem
with round end: 35,
44, 60, 80 & 100mm



▲ BWT-Valve-L2
tubeless Valve stem
with square end: 29,
44, 55, 60, 70, 80,
90 & 110mm



▲ BWT-Valve-LE
tubeless Valve
extension: 38, 50
& 70mm



▲ CFA-4001
Carbon fiber assembly
compound, 2g, 6g, 80g, 300g



New



▲ BCN-226
Light mount & RD protector

hubsmith

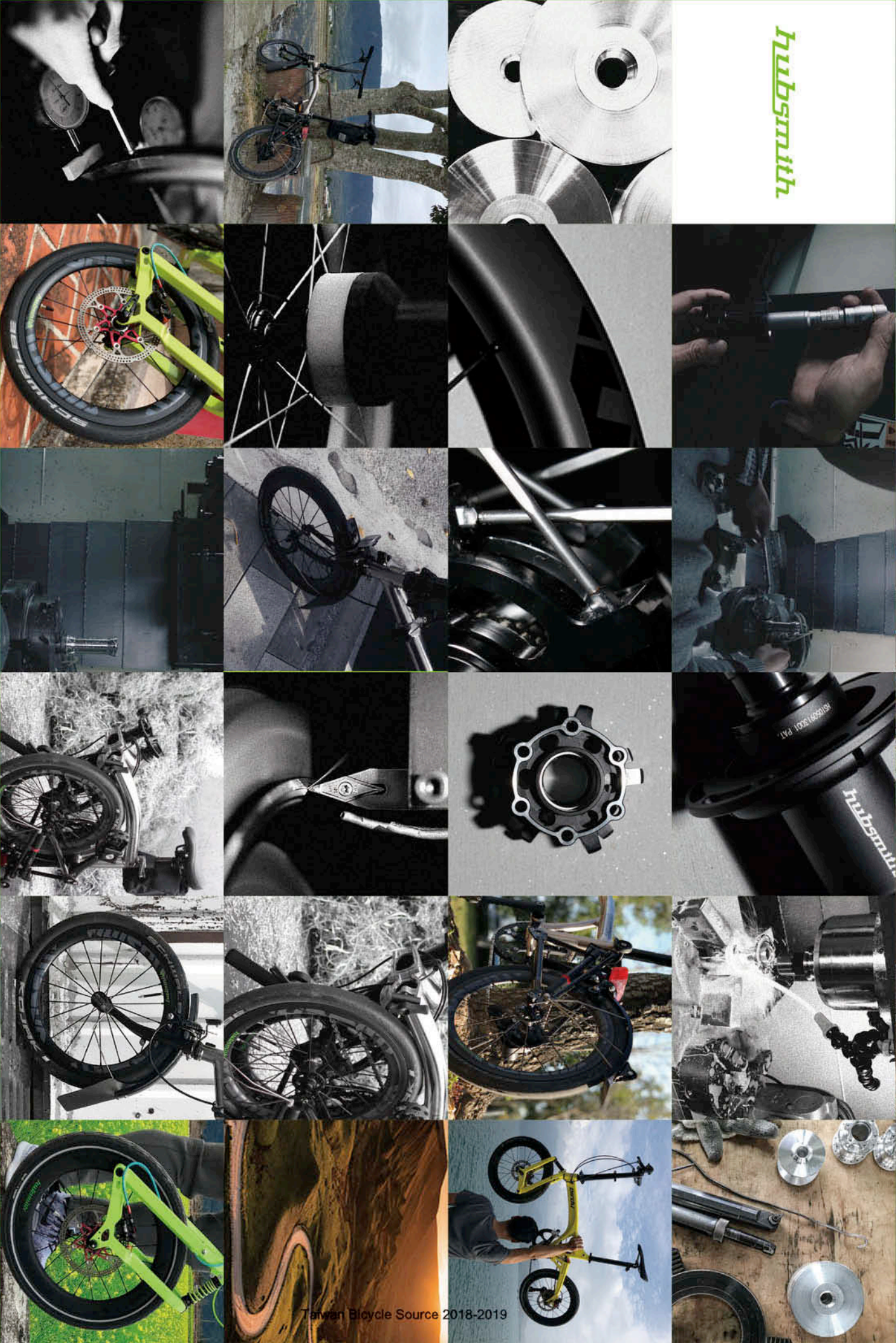

9 No.808, Sec7, Hanxi E. Rd., Fengyuan Dist., Taichung City 420, Taiwan
☎ +886 4 25379168 📧 ctf@hubsmith.com / hubsmith.taiwan@gmail.com

hubsmith.com



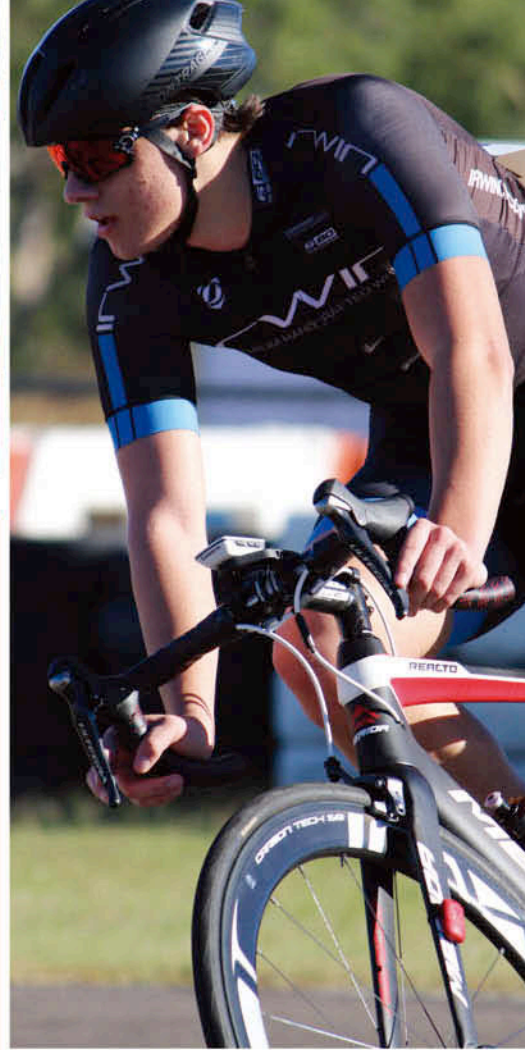

**POWERING THE WORLD'S
ELITE RACERS AND
TRIATHLETES TO
VICTORY.**



IRWIN™
INNOVATION DRIVEN. RACE PROVEN.

Driven by innovation, IRWIN designs and manufactures a highly distinctive range of wheelsets for the most demanding cyclists around the world.

LOOKING FOR DISTRIBUTORS

IRWIN CO., LTD.

TEL +886-2-8791-7296

FAX +886-2-8792-1259

E-MAIL sales@irwincycling.com

WWW.IRWINCYCLING.COM

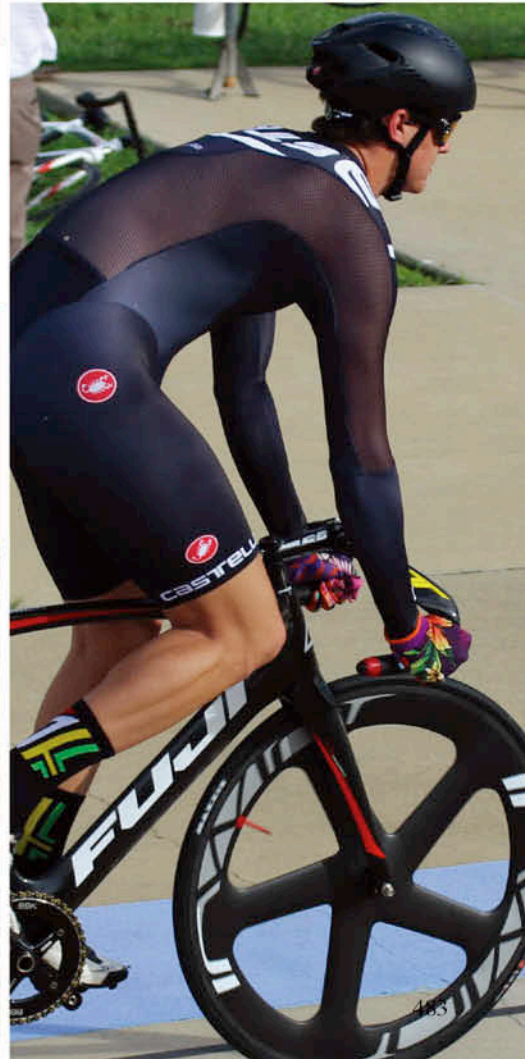

ROAD DISC

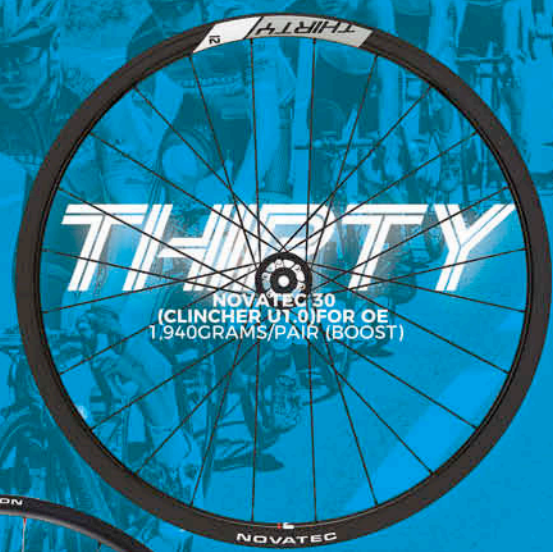
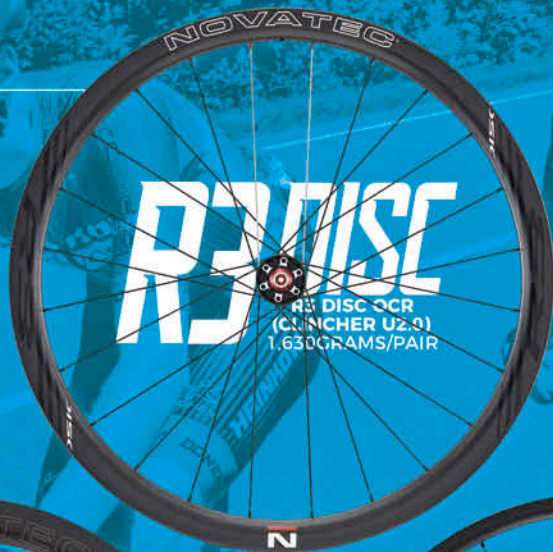

MTB

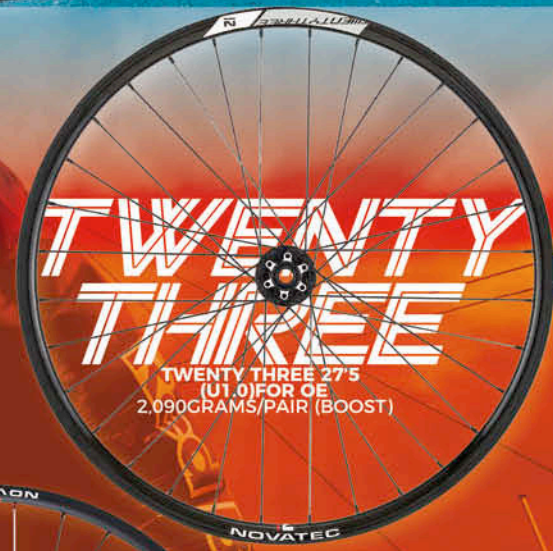
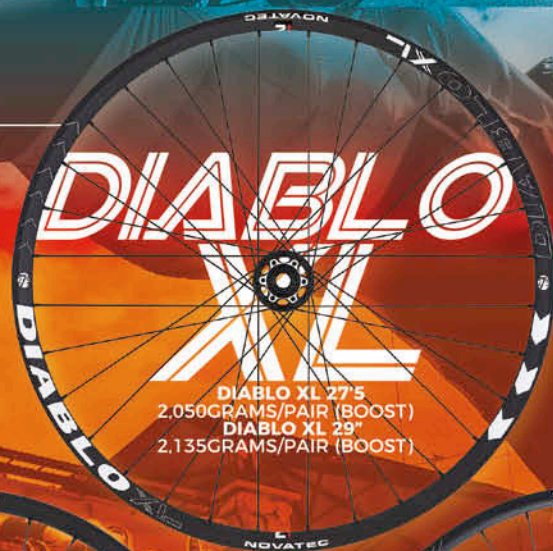

Kashima

ISO 9001

KASHIMA BIKE INTERNATIONAL CO.,LTD

TEL:886-4-7620861 www.kashima.com.tw

FAX:886-4-7620860 E-mail:bike@kashima.com.tw

MODEL:KA-RH50C ▶

CARBON 50MM RIMS RACING WHEELSET

M12*100/M12*142/TUBELESS READY

(Available with QR)



▶ MODEL:KA-RH700

ALLOY RIMS RACING WHEELSET

M12*100/M12*142 (Available with QR)



Tel:+886-4-8811109
 Email: info@speeforward.com
 Address:
 No.17-9, Lunzijiao Rd., Xihu Township,
 Changhua County 514, Taiwan

HAND WHEEL BUILDING



HAND BUILDING QUALITY YOUR WHEEL CHOICE

MTB
 ROAD
 PUSH BIKE
 TRI
 CYCLE
 BMX SFD WHEEL

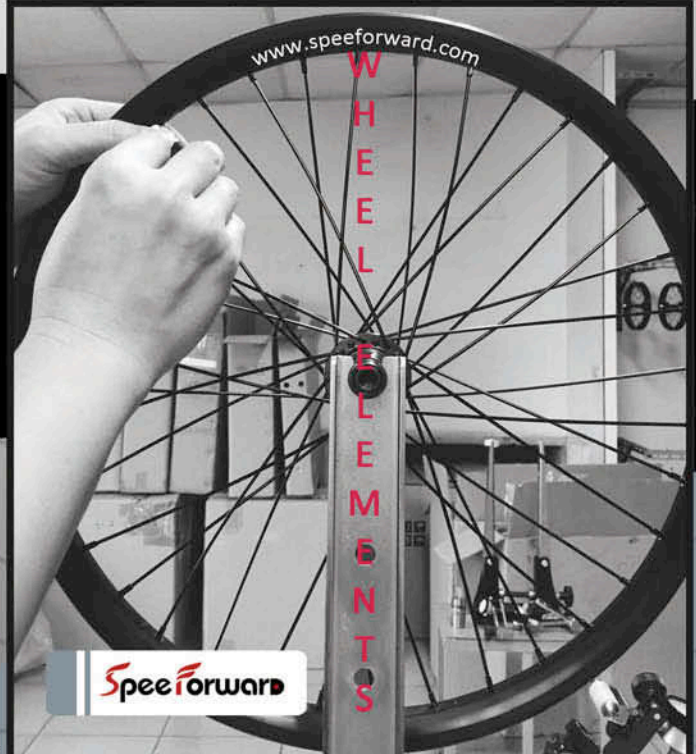

SpeeForward

www.speeforward.com
 W
 H
 E
 E
 L
 E
 L
 E
 M
 E
 N
 T
 S

S
 F
 D

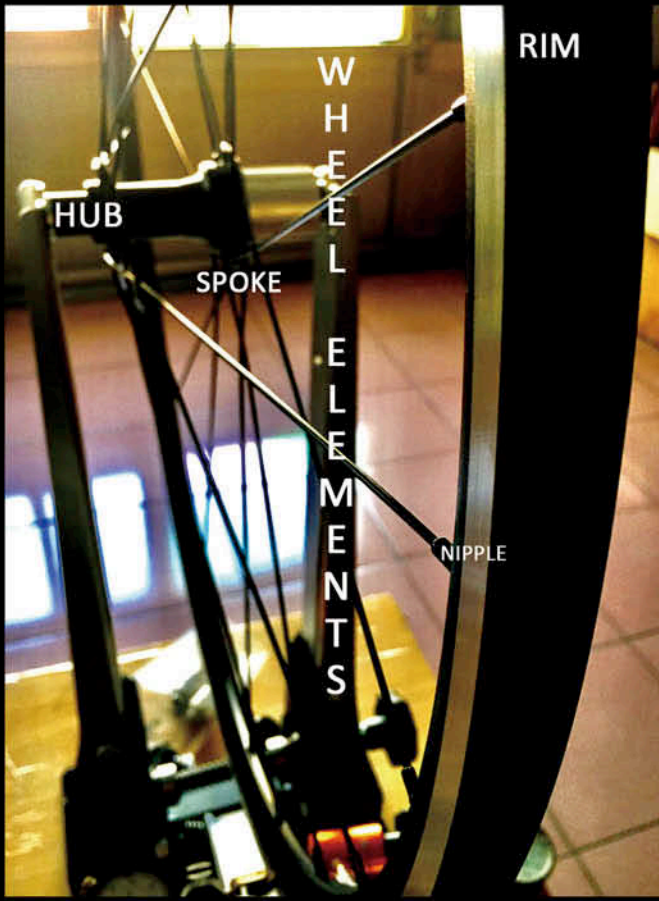

HUB
 SPOKE
 W
 H
 E
 E
 L
 E
 L
 E
 M
 E
 N
 T
 S
 NIPPLE
 RIM

OEM ODM



SFD



Road R58c

Size : 700C / 58
Rim Material : Carbon Fiber
Weight : F-805g R-945g
Spoke : Pillar / 1425
Freehub Body : Shimano
Tire type : Clincher

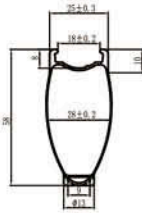

Road R45c R35c

Size : 700C / 45c
700C / 35c
Rim Material : Carbon Fiber
Weight : F-830g(45c) R-935g(45c)
Spoke : Pillar / 1425
Freehub Body : Shimano
Tire type : Clincher

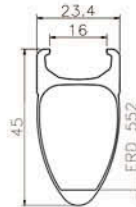

Road M25c

Size : 650B
Rim Material : Carbon Fiber
Weight : F-675g R-790g
Spoke : Pillar / 1425
Freehub Body : Shimano
Tire type : Clincher

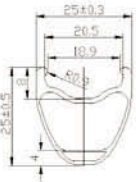

Road R48c

Size : 700C / 48
Rim Material : Carbon Fiber
Weight : F-725g R-875g
Spoke : Pillar / 1425
Freehub Body : Shimano
Tire type : Clincher

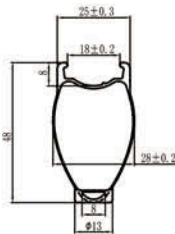

Road R38c

Size : 700C / 58
Rim Material : Carbon Fiber
Weight : F-800g R-915g
Spoke : Pillar / 1425
Freehub Body : Shimano
Tire type : Clincher

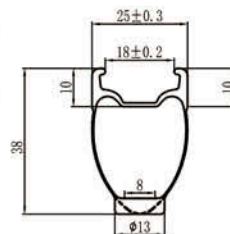



OXTEC
Multinational PATENT

Hubs have a
limitless angle of the
engagement
mechanism and lower
resistance structure,
which, difference
from a regular.



Tai-World MFG. Co., Ltd.

No. 773 Changsao Rd, Changhua City,
Changhua County, 50067 Taiwan
TEL:+88647511838 FAX:+88647512768
<http://www.masstec.com.tw>
Email:bike@masstec.com.tw



多元完整性的系列開發 環繞延展的速度美學概念



ADOLU

ADOLU 58.8
 USAGE: Road / Triathlon
 RIM: 700x58.8 / CARBON Fiber
 HUB: Sharp / Seal Bearing / SHIMANO, SRAM
 DT240 / Seal Bearing / SHIMANO, SRAM
 SPOKE: SAPIM CX-RAY / DT SWISS AEROLITE
 WEIGHT: Sharp / Sapim CX-RAY / 1550g
 DT240 / DT SWISS AEROLITE / 1490g



VULUNG

Vulung 38.8
 USAGE: Road / Triathlon
 RIM: 700x38.8 / CARBON Fiber
 HUB: Sharp / Seal Bearing / SHIMANO, SRAM
 DT240 / Seal Bearing / SHIMANO, SRAM
 SPOKE: SAPIM CX-RAY / DT SWISS AEROLITE
 WEIGHT: Sharp / Sapim CX-RAY / 1430g
 DT240 / DT SWISS AEROLITE / 1370g

信振複材
 THINKCHANGE
 碳纖維精品設計製造

-  續動循環(Rotating Maintain Design ; RMD)
透過結構計算及碳纖維疊手法讓轉動慣性最優化
-  框體鋼化(Solid Frame Design ; SFD)
藉由精密碳纖維疊管強化增強輪圈強度提升踩踏驅動剛性
-  溫度控管(Temperature Control ; TC)
大幅降低碳纖維交疊面積，提供穩定溫度控制
-  循跡設定(Traction Control Design ; TC)
24mm框寬，提供絕佳接觸面積更能穩定操控
-  六爪棘輪系統(6 pawls System)
順應車手的踩踏動作，迅速咬合，做出精準即時反應
-  2:1編法結構(2&1 LACING)
透過左右不同張力設定，提供最佳輪條張力平衡
-  加大花轆耳設計(OVERSIZE FLANGE)
縮短輪條長度提升側向剛性，及轉彎側傾的拉撐效能
-  內壓防水側蓋
兩側側蓋內縮至軸心內側，降低泥水侵入機率

2018 MTB CARBON RIMS

Model	XC		TRAIL			ENDURO			DH		PLUS	CX & Gravel
	MX930XC	MX932XC	MX932TR	MX935TR	MX942TR	MX935EN	MX942EN	MX935DH	MX942DH	MX950+	GCX28	
Weight	340	350	390	410	430	460	480	540	560	510	380	
Internal Width	24.5	26	26	29	36	29	36	29	36	43	21	
External Width	30	32	32	35	42	35	42	35	42	50	28	
Profile / Height	23.5	25	25	23.5	25	23.5	25	23.5	25	25	29	
ERD	598	595	595	598	595	598	595	598	595	595	589	
Tyre Fit	2.0-2.4	2.0-2.4	2.3-2.5	2.3-2.5	2.5-2.8	2.3-2.5	2.5-2.8	2.3-2.5	2.5-2.8	2.8-3.0	32-40mm	
Model	MX730XC	MX732XC	MX732TR	MX735TR	MX742TR	MX735EN	MX742EN	MX735DH	MX742DH	MX750+	GCX35 Road+	
Weight	320	330	370	390	410	440	460	520	540	470	360	
Internal Width	24.4	26	26	29	36	29	36	29	36	43	24	
External Width	30	32	32	35	42	35	42	35	42	50	32	
Profile / Height	23.5	25	25	23.5	25	23.5	25	23.5	25	25	35	
ERD	560	557	557	560	557	560	557	560	557	557	537	
Tyre Fit	2.0-2.4	2.0-2.4	2.3-2.5	2.3-2.5	2.5-2.8	2.3-2.5	2.5-2.8	2.3-2.5	2.5-2.8	2.8-3.0	32-47mm	

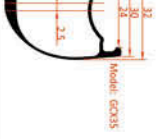
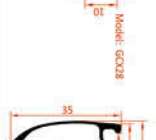
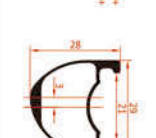
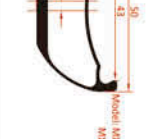
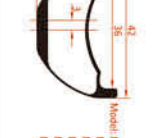
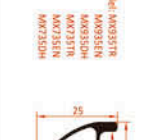
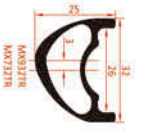
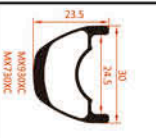

3/5/DISC WHEELS

23mm width
 Tubular & Clincher
 Front & Rear
 Road, Triathlon, Fixed Gear



Tri spokes:
 795g~1140g



Five spokes:
 795g~1140g



Disc spokes:
 1060~1400g

700c Road Rim Brake

Cinchler / Tubeless Ready										Tubular									
Model	RX30SH	RX38SH	RX38DH	RX45SH	RX50SH	RX50DH	RX60SH	RX88SH		Model	RT30S	RT38S	RT38D	RT50S	RT50D	RT60S	RT88S		
Height (mm)	30	38	38	45	50	50	60	88		Height (mm)	30	38	38	50	50	60	88		
Weight (g/pc)	430	470	470	480	500	500	560	680		Weight (g/pc)	310	360	360	410	410	470	530		
IW (mm)	18	18	18	18	18	18	18	18		IW (mm)	18	18	18	18	18	18	18		
IW (mm)	18	18	18	18	18	18	18	18		IW (mm)	18	18	18	18	18	18	18		
EW (mm)	28	27	27	28	28	28	28	28		EW (mm)	28	27	27	28	28	28	28		
ERD	553	569	569	555	545	545	525	469		ERD	553	569	569	545	545	525	469		
Resin System	Tg255° / Tg210°									Tg210°									
Brake Track	3K Twill / Basalt									3K Twill / Basalt									
Cross-section										Cross-section									
Cinchler / Tubeless Ready										Tubular									
Model	DX30S	DX38S	DX38D	DX45S	DX50S	DX50D	DX60S	DX88S		Model	DT30S	DT38S	DT38D	DT50S	DT50D	DT60S	DT88S		
Height (mm)	30	38	38	45	50	50	60	88		Height (mm)	30	38	38	50	50	60	88		
Weight (g/pc)	360	400	400	430	450	450	500	680		Weight (g/pc)	270	320	320	360	360	430	530		
IW (mm)	18	18	18	18	18	18	18	18		IW (mm)	18	18	18	18	18	18	18		
IW (mm)	18	18	18	18	18	18	18	18		IW (mm)	18	18	18	18	18	18	18		
EW (mm)	27	27	27	28	28	28	28	28		EW (mm)	28	27	27	28	28	28	28		
ERD	553	569	569	555	545	545	525	469		ERD	553	569	569	545	545	525	469		

700c Road Disc Brake

**WANT TO BECOME
A DISTRIBUTOR OR AGENT?**

visit us here



STORAX



Wheel: 26" / 27.5"
Weight: 520g / 540g
Holes: 32H / 36H

Double Butted
Rise: 20° / 40°
Length: 760 / 800 mm
Bar bore: 31.8 mm

Handle Grip Flight
TPR Kraton with exclusive
wear-resistance material

BCD: 104mm
(Narrow-Wide)
Material: AL7075
Teeth: 32T / 34T / 36T
Weight: 49g / 57g / 66g

Wheel: 26"
Weight: 520g
Holes: 32H / 36H
Width: 28mm

Double Butted
Rise: 0°
Length: 760 mm
Bar bore: 31.8 mm



信大工業股份有限公司
Hsing Ta Industrial Co., Ltd
台中廠(Taichung)
220台中市烏日區大明北路187-1號
No.187-1, Taiming N Rd., Wuri Dist.,
Taichung City, Taiwan.
T 886-4-23359257 F 886-4-23359903
Email:sales@ms.hti-pedal.com.tw

信大塑膠五金(深圳)有限公司
Hsing Ta Industrial(Shenzhen) Co., Ltd
深圳廠(China)
中國深圳市寶安區沙井鎮后亭村第三工業區沙松路69號
Bldg. #12, 3th Ind. Area, Hou-Ting Tsun,
Sha-Jing Town, Bao-An Dist., Shenzhen.
T 86-755-27222566 F 86-755-27562790
Email:sales@ms.hti-pedal.com.tw

SPOKES

Type MTB / Road / BMX / Trekking / City Material Sandvik 302T(18/10) / Stainless 304 / Steel Certificate JIS D 9420 / JIS B 0225
Thread Rolled (BC 56 / DIN 79012) Colors Silver / XD Black / XD matte Black / ED black / PVD colors / Powder coating colors

PRO	SANDVIK	H14	170-310mm	ø2.0 mm	6.5g
	XM	H15	170-310mm	ø1.8 mm	5.5g
	XD				
AERO	SANDVIK	HB423	170-310mm	ø2.0 mm	aero 2.3mm 6.5g
	Bladed	HB432	170-310mm	ø2.0 mm	aero 3.2mm 6.5g
	XM				
PRO DB	SANDVIK	HDB415	190-310mm	ø2.0 - 1.8 - 2.0mm	5.7g
	Double Butted	HDB416	190-310mm	ø2.0 - 1.6 - 2.0mm	4.7g
	XM	HDB417	190-310mm	ø2.0 - 1.5 - 2.0mm	4.3g
	XD	HDB415	straight pull	190-310mm	ø2.0 - 1.8 - 2.0mm
DB AERO	SANDVIK	HDBA415	190-310mm	ø2.0 - 1.8 - 2.0mm	aero 2.5mm 5.7g
	Bladed	HDBA416	190-310mm	ø2.0 - 1.6 - 2.0mm	aero 2.2mm 4.7g
	Double Butted	HDBA417	190-310mm	ø2.0 - 1.5 - 2.0mm	aero 2.0mm 4.3g
	XM	HDBA415	straight pull	190-310mm	ø2.0 - 1.8 - 2.0mm
XD					

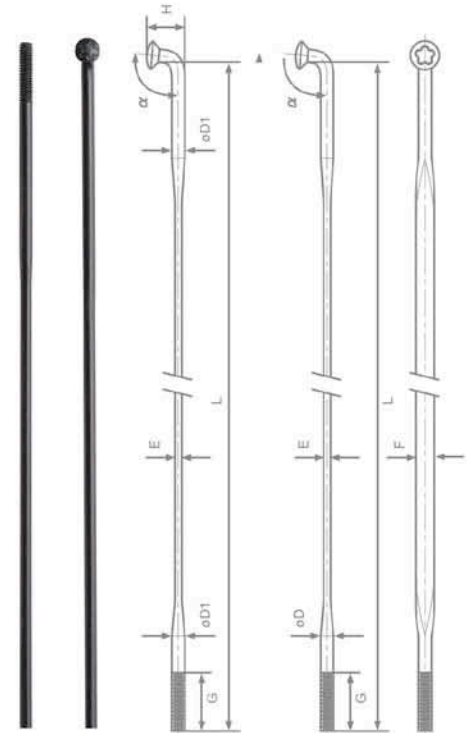

NIPPLES

PRO HIDDEN		PRO TRI HEAD	
Type	MTB / Road / Enduro	Type	MTB / Road / Enduro
Material	7075 aluminum / Brass	Material	7075 aluminum / Brass
Length	12 mm / 14 mm	Length	16 mm / 18 mm
Thread	Ø 2.0 mm	Thread	Ø 2.0 mm
Colors	Anodized colors NP silver / ED black	Colors	Anodized colors NP silver / ED black
Weight	Aluminum 0.28 grams / pcs (14G * 12 mm length)	Weight	Brass 1.18-1.19 grams / pcs Aluminum 0.397 grams / pcs (14G * 16 mm length)
LOW LEAD BRASS (Pb<100ppm) series		ALUMINIUM series	
Type	for all type	Type	for all type
Material	low lead brass (pb<100ppm)	Material	7075 aluminum
Length	12 mm / 14 mm / 16 mm	Length	12 mm / 14 mm / 16 mm
Certificate	CPSIA / REACH	Thread	BC 1.8 / 2.0
Thread	BC 1.8 / 2.0	Colors	anodized colors
Colors	NP silver / ED Black		



SHA DAR ACCESSORIES CO., LTD

No.4-2 Lane 20, Pae-Nae St., Shu Lin Dist., New Taipei City 23849, Taiwan

TEL: + 886 2 2686 8277 FAX: + 886 2 2681 5966 OEM: sales@pillarspoke.com A.M.: pillar@topventurer.com

TECHNOLOGY



Colour Series

Powder Coating [For Any Material]



Anodize Colour [For Alloy Nipple]



Ceramic Nanometer Ti Plating
[For Stainless Steel]



Nipple Series

External Nipple

TG Nipple

Internal Nipple [Hidden]



Type:PB14 / PT734



Type:PB14H / PT734H



Type:MV / HS



Type:DSN



Type:TG Brass / TG Alloy



Type:Hex 10



Type:5R

Tools / Accessories

■ Aero Spoke Holder



■ Spoke Wrench



■ Spoke Tension Meter



■ Tps Tool



■ Hand Tool



■ Spoke Box



■ Washer



Type:PW6035

Type:PW7048

■ Ruler



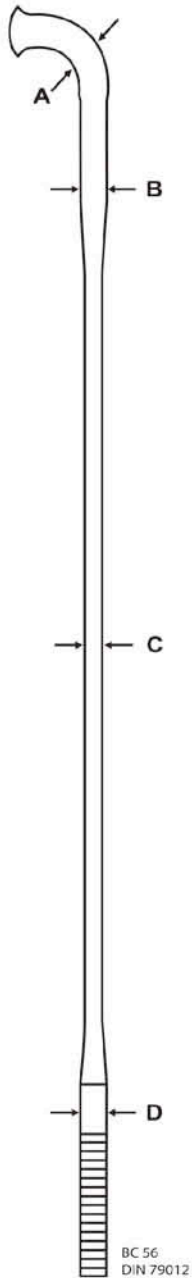

PLAIN GAUGE

SPOKE

BUTTED

SPOKE

AERO

SPOKE

New Product

WING

SPOKE

SUPER LITE

SPOKE

3D FORCE

SPOKE

	A (mm)	B (mm)	C (mm)	D (mm)	weight (260mm)
P 13	2.3	2.3	2.3	2.3	8.5 g
P 14	2.0	2.0	2.0	2.0	6.5 g
P 15	1.8	1.8	1.8	1.8	5.5 g
* PSR 13	2.5	2.3	2.3	2.3	8.5 g
* PSR 14	2.2	2.0	2.0	2.0	6.5 g
* PSR 15	2.0	1.8	1.8	1.8	5.5 g
PSB 34	2.3	2.3	2.0	2.0	6.8 g
PSB 45	2.0	2.0	1.8	1.8	5.6 g
PDB 1415	2.0	2.0	1.8	2.0	5.7 g
PDB 1416	2.0	2.0	1.6	2.0	4.7 g
PDB 1417	2.0	2.0	1.5	2.0	4.3 g
PTB 380	2.3	2.3	1.8	2.0	6.3 g
PTB 270	2.2	2.2	1.7	2.0	5.3 g
* PSR TB 2018	2.2	2.0	1.8	2.0	5.7 g
* PSR TB 2017	2.2	2.0	1.7	2.0	5.2 g
* PSR TB 2016	2.2	2.0	1.6	2.0	4.7 g
* PSR TB 2015	2.2	2.0	1.5	2.0	4.3 g
PSR QB 5380	2.5	2.3	1.8	2.0	6.3 g
PSR QB 4270	2.4	2.2	1.7	2.0	5.8 g
PA 1423	2.0	2.0	2.3 x 1.5	2.0	6.5 g
PA 1432	2.0	2.0	3.2 x 1.0	2.0	6.5 g
PA 1528	1.8	1.8	2.8 x 1.0	1.8	5.5 g
PBA 1425	2.0	2.0	2.5 x 1.05	2.0	5.7 g
PBA 1422	2.0	2.0	2.2 x 0.95	2.0	4.7 g
PBA 1420	2.0	2.0	2.0 x 0.95	2.0	4.3 g
* PSR Aero 1423	2.2	2.0	2.3 x 1.5	2.0	6.5 g
* PSR Aero 1432	2.2	2.0	3.2 x 1.0	2.0	6.5 g
* PSR Aero 1528	2.0	1.8	2.8 x 1.0	1.8	5.5 g
* PSR X-TRA 1425	2.2	2.0	2.5 x 1.05	2.0	5.7 g
* PSR X-TRA 1424	2.2	2.0	2.4 x 1.05	2.0	5.2 g
* PSR X-TRA 1422	2.2	2.0	2.2 x 0.95	2.0	4.7 g
* PSR X-TRA 1420	2.2	2.0	2.0 x 0.95	2.0	4.3 g
* PSR WING 23	2.2	2.0	2.3 x 1.5	2.0	5.7 g
* PSR WING 22	2.2	2.0	2.2 x 1.4	2.0	5.2 g
* PSR WING 21	2.2	2.0	2.1 x 1.3	2.0	4.7 g
* PSR WING 20	2.2	2.0	2.0 x 1.2	2.0	4.3 g
PST 14	2.2	2.0	2.0	2.0	4 g
PST AERO 1430	2.2	2.0	3.0 x 1.1	2.0	4 g
MEGA LITE SS	2.0	2.0	1.7 x 0.9	2.0	3.5 g
X-TRA LITE Ti	2.3	2.3	2.0 x 0.9	2.3	2.6 g

Items marked with * are available for 3D FORCE.



Alloy

PAT. Internal Nipple
Easy to lock

SIX UNION

Spokes & Nipples

Product Description

SPOKE

Changing The Way Bicycle Wheel Sets Are Made

SPECIFICATION : 8G to 15G

LENGH: Any Length By Order

MATERIAL: High Tension Stainless Steel,

Stainless Steel, Steel, Titanium

FINISH: UCP, ED, XD, POWDER COATING, CP , PVD

NIPPLES

MATERIAL: Titanium, Aluminum, Brass, Steel

SPECIFICATION: 8G to 15G

LENGH: 12/14/16/18/20/22mm

FINISH: UCP, ED, PC, CP



HIGH TENSION -STAINLEDD STEE



Titanium Nipple
PAT.



ARC Fit
For Motor **PAT.**



Powder Coating Spoke

ARC Fit Tools



AL Nipple



ARC-Fit Nipple Tools

ARC Fit
AL Nipple **PAT.**



ARC Fit
PAT.



Titanium Nipple

ED Color Spoke



六合機械企業股份有限公司

Six Union Machine Enterprise Co., Ltd.

51341 臺灣彰化縣埔心鄉中正路一段192號

51341 No.192 CHUNG JANG ROAD, SEC.1 PU SING CHANG HWA, TAIWAN

TEL : 886-4-8293156

FAX : 886-4-8294817

E-Mail: Jason@sixunion.com

Skype: jason-chen-

<http://www.sixunion.com>

DUBAI INTERNATIONAL
BICYCLE
EXHIBITION



Join us at the cycling exhibition for the MENA region

JANUARY 11TH - 12TH 2019 | DUBAI WORLD TRADE CENTRE



2nd Edition of the exhibition



Over 120 Independent bicycle dealers in the GCC



Over 55 Independent bicycle dealers in the UAE

Business visitors from 24 countries attended the 1st edition



@DubaiBicycleShow
#DubaiBicycleShow

DUBAIBICYCLESHOW.COM

Contact us for more information about participating at the exhibition

Jean Huang,

WHEEL GIANT INC.
886-4-7350500, 7352555

F: 886-4-7357860, 7360789
E: rep@mail.wheelgiant.com.tw

Organised by



RIMNETE

Assess Industry Co., Ltd.

#11, Lane 135, Section 5, ChanPing Rd. Shengang District,

Taichung City, Taiwan

Tel: +886 4 25623506 Fax: +886 4 25613868

sales@assess-hubs.com



DH07FD



M06FDQ/RDQ



M04FDQ/RDQ



M12FDQ/RDQ



RA08FQ/RQ

RA09RQ



RA32FDQ/RDQ



RA17FQ/RQ



BX03FSA/RSA



BX05RSA



CX07RSB



BX31FSA/RSA

<http://www.assess-hubs.com>



AE-920FDQ/RDQ



AE-970FDQ/RDQ



AE-806FD/RD



AE-718FQ/RQ



AE-641F/R



AE-701FQ/RQ



AE-436/AE-433A



AE-613F/AE-347R



C420F/R



AE-515/AE-505



AE-518



DX50RS

For Wheelchair

For Wheelchair



HUB FACTORY



Made in Taiwan

Freehub Body

THE SOUL OF THE BIKE.

Patented



6 Pawls System

Taiwan - M425782

China - ZL 2011 2 04061190

Germany - Nr. 20 2011 051 875.2

USA - US 8,443,951 B1

Anti-Bite

Anti-Bite System

Taiwan - M519075

China - ZL 2015 2 0925200.8

Germany - Nr. 20 2015 106 474

USA - Processing

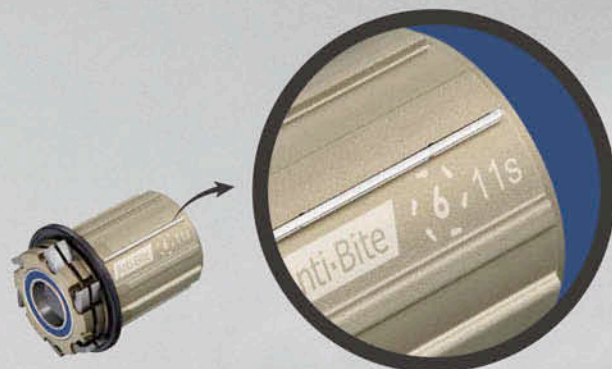

Our Freehub Body come with a 6 pawl system which doubles the points of engagement in our Road Hubs from 24 to 48 and in our Mountain Hubs from 27 to 54.

We have also added an Anti-Bite System of three small, hardened stainless splines to our Freehub body. Anti-Bite System is to prevent the gouging from the cassette to the Freehub Body, could leave ugly notches that make removing the cassette difficult.



MTB Hub
Boost / Centerlock
BX212F 140g



MTB Hub
Boost / Centerlock
BX212R 260g



www.bitexhubs.com
min@bitexhubs.com

We will be here with you.



MINI-74
For Folding Bike
Alloy, Sealed Bearing x 2pcs
PCD:29 / OLD:74, Weight:53g



FD-130QR (Disk)
For MTB-Disk, QR Type
Alloy Body, 28H / 32H / 36H.
Flange Space : 58mm
Flange PCD : 58mm



FD-130 (Disk)
For MTB-Disk, Nut Type
Alloy Body, 28H / 32H / 36H.
Flange Space : 58mm
Flange PCD : 58mm



QR-100 QR-135



RD-130QR (Disk)
For MTB-Disk, QR Type
Alloy Body, 28H / 32H / 36H.
Flange Space : 58mm
Flange PCD : 58mm



RD-130 (Disk)
For MTB-Disk, Nut Type
Alloy Body, 28H / 32H / 36H.
Flange Space : 58mm
Flange PCD : 58mm



F2001



F2002QR



F2003QR



R2101



R2102QR



R2103QR

型號	Model	F2001	R2101	F2002QR	R2102QR	F2003QR	R2103QR
本體	Shell	1Pc Cold Forged Alloy					
PCD長 孔數	P.C.D -Spoke Hole	C=38mmx28/36Hx14G	C=45mmx28/36Hx14G	C=38mmx28/36Hx14G	C=45mmx28/36Hx14G	C=38mmx28/36Hx14G	C=45mmx28/36Hx14G
葉距	Flange Distance	B=72	B=57	B=72	B=57	B=72	B=57
飛輪 XOLD長 X軸長	E(Freewheel) xA(O.L.D.) xD(Axle Length)	AxD=100x130	ExAxD=36.0x126x170	AxD=100x108	ExAxD=36.0x126x136	AxD=100x108	ExAxD=36.0x126x136
類別	Type	Nut-Type / Front	Nut-Type / Rear	QR-Type / Front	QR-Type / Rear	QR-Type / Front	QR-Type / Rear



R-220R F-068



R-220M (V-brake) F-120 (V-brake)



RD-240 (D-brake) FD-140 (D-brake)

型號	Model	F-068	R-220R	F-120	R-220M	FD-140	RD-240
本體	Shell	-	Forged 7075	1 Pcs Color Forged Alloy 6061	Forged 7075	Forged 7075	Forged 7075
PCD長	Cassette Body PCD Length	-	-	-	-	-	-
孔型-孔位	Hole Type & Offset	-	-	Round (Offset / Non-Offset) or Butterfly(Offset / Non-Offset) or Slotted (Offset / Non-Offset / Slope 5') to order	-	-	-
孔數	Hole Q'ty	-	-	10 / 12 / 16 / 18 / 20 / 24 / 28 / 32 to order	-	-	-
軸心	Axle	-	-	A6061-Hollow	-	-	-
培林	Sealed Bearing	(SB064159050B0)	(SB150260070B0) (SB150280070B0)	(SB150260070B0)	(SB150260070B0) (SB150280070B0)	(SB150260070B0)	(SB150260070B0) (SB150280070B0)
OLD長-軸長	OLD-Axle Length	(100x108)	(130x140)	(100x108)	(135x145)	(100x108)	(135x145)
防水	Waterproof Cap	-	-	-	Rubber	-	-
快拆	Quick Release (Option)	QR-100	QR-130	QR-100	QR-135	QR-100	QR-135
類別	Type	Front	Rear	Front	Rear	Disk-Front	Disk-Rear
車軸牙機	Rotator	-	-	-	-	-	-
適用於	For	Racing	Racing, MTB	MTB	Racing, MTB	MTB	MTB
表面塗裝	Finish	-	-	Anodized Silver, Anodized Black	-	-	-
重量	Weight	67g	210g	116g	215g	148g	237g

ASP1386BA



ASP7647BK-11S(TC)



ASP1426BA



ASP5757BH-11S(150T)



ASP1616BA



ASP7677BK-11S(TC)



ASP7697BH-11S(150T)



ASP7677BO-11S



ASP1316BA



ASP5607BG-11S



ASP1686BA



ASP7287BGA-11S



ASP1586BA



ASP7187BOA-11S



A1146BA



A1386BA





A1766BA



A5207BK-11S(TC)



A5857BH-11S(150T)



A7577BXO-11S



A5647BG-11S



A5047BG-11S



ASP8216B-M15(CX)



ASP8217BK-142(TC CX)



ASP8506B(CX)



ASP8507BH(150T CX)



A8406BX(CX)



A8407BH(150T CX)



A8586BX-M15



DA8237BK-142(TC)



ASP8516B-M15



ASP8517BOH-142(150T)



ASP8786B



ASP8787BOH-142(150T)



DA8426BX-M15



DA8427BOH-142(150T)



A8586BX-M15



A8587BOH-142(150T)



ASP8316B-M15-110(Boost)



ASP8317BK-148(TC Boost)



ASP8786B-M15-110(Boost)



DASP8787BOH-148(150T)



DA4841B-M15-110(Boost)



DA8576B-M15-110(Boost)



DA8237BK-148



DA8587BOH-148(150T)



DA8277B-148(Boost)



DA4083B-D





ASP8506B-M15(CX)



ASP8507BO-11S(CX)



A8406BX-M15(CX)



A8407BO-11S(CX)



ASP8356B



ASP8257B



DA8236B-QR



DA8277B-QR



ASP433B-M15



ASP4167B-142



DA8596B-QR



DA4577B-QR



A4786B-M15-135



A4786B-M15-150



A8777B-190-QR



A8777B-170-QR



A3633B-H



A3735B-H



UA4101BX (SUPERMAX29er)



T19(LEFTY)



A1343B-BOLT



A5045BH-BOLT



A2643B



A9585BX-14-9T



A1453B-BOLT



A6245BXP-14-BOLT



T4B



A5217B-FN-130



A4217B-FN-135



A4581B



A4587B



A4582B-TR





FORMULA ENGINEERING INC.

807, Feng Gong Rd., Sheng Kang Dist., Taichung City, Taiwan.
 Tel:886-4-25202755 Fax:886-4-25293478
 www.formulahubs.com E-mail:marketing@formulahubs.com



F / R	Mechanism	Spoke Count	O.L.D.	Axle Length	QR	Weight
EHL-148S	R	4SB	28 / 32	148mm	12mm	n/a 390g
EHL-148A	R	4SB	28 / 32	148mm	12mm	n/a 335g
EHL-1481	R	4SB	28 / 32	148mm	12mm	n/a 360g
EHL-1482	R	4SB	28 / 32	148mm	12mm	n/a 330g

*EHL-1481 for Sram XD system

F / R	Mechanism	Spoke Count	O.L.D.	Axle Length	QR	Weight
ECT-148S	R	4SB	28 / 32	148mm	12mm	n/a 375g
ECT-148A	R	4SB	28 / 32	148mm	12mm	n/a 320g
ECT-1481	R	4SB	28 / 32	148mm	12mm	n/a 340g

*ECT-1481 for Sram XD system

Boost Hub - 6 bolt



F / R	Mechanism	Spoke Count	O.L.D.	Axle Length	QR	Weight
DC-711	F	SB	28 / 32	110mm	15mm	n/a 185g
DHT-148S	R	4SB	28 / 32	148mm	12mm	n/a 395g
DHT-1481	R	4SB	28 / 32	148mm	12mm	n/a 360g

*DHT1481 for Sram XD system

F / R	Mechanism	Spoke Count	O.L.D.	Axle Length	QR	Weight
TD-711	F	SB	28 / 32	110mm	15mm	n/a 133g
TD-148S	R	4SB	28 / 32	148mm	12mm	n/a 310g
TD-1481	R	4SB	28 / 32	148mm	12mm	n/a 290g

*TD1481 for Sram XD system

Boost Hub - Center lock



F / R	Mechanism	Spoke Count	O.L.D.	Axle Length	QR	Weight
CL-811	F	SB	28 / 32	110mm	15mm	n/a 125g
CL-148S	R	4SB	28 / 32	148mm	12mm	n/a 360g
CL-1481	R	4SB	28 / 32	148mm	12mm	n/a 295g

*CL1481 for Sram XD system

F / R	Mechanism	Spoke Count	O.L.D.	Axle Length	QR	Weight
TC-711	F	SB	28	110mm	15mm	n/a 125g
TC-148S	R	4SB	28	148mm	12mm	n/a 310g
TC-1481	R	4SB	28	148mm	12mm	n/a 295g

TC1481 for Sram XD system

Road Disc



F / R	Mechanism	Spoke Count	O.L.D.	Axle Length	QR	Weight
RX-812	F	SB	24 / 28 / 32	100mm	12mm	n/a 138g
RX-300	R	4SB	24 / 28 / 32	142mm	12mm	n/a 300g
RX-301	R	4SB	24 / 28 / 32	142mm	12mm	n/a 300g

*RX301 for Sram XD system

F / R	Mechanism	Spoke Count	O.L.D.	Axle Length	QR	Weight
CL-712	F	SB	24 / 28 / 32	100mm	12mm	n/a 150g
RXC-142S	R	4SB	24 / 28 / 32	142mm	12mm	n/a 355g
RXC-142A	R	4SB	24 / 28 / 32	142mm	12mm	n/a 305g

P.A.T.M522867



**E-BIKE / HUB
HUB-EB758-R**

Holes : 32 / 36 H
AXLE : AL7075 T6
AXLE DIAM : OD. Φ 17 / ID. Φ 12
O.L.D : 148 mm
Bearings : 4 pcs
PCD : 58 mm
Weight : 284 g
NOTE : M12
Shimano 11 sp or
Sram XD Cassette



**E-BIKE / HUB
HUB-EB758-F**

Holes : 32 / 36 H
O.L.D : 110 mm
Bearings: 2 pcs
PCD : 58 mm
Weight : 194 g
NOTE : M15

RACE PROVEN!

Amoeba[®]
www.amoebaparts.com

Vist www.amoebaparts.com to see more

RACE PROVEN!
Amoeba[®]
www.amoebaparts.com

JINN-YEH Industrial Co., Ltd
Tel: +886-4-8815065 Fax: +886-4-8817065
Email: amoeba.tw@msa.hinet.net
46, Lane 201, Sec. 1 Ta-Shi Rd., Shi-Hu 514, Chang-Hua, TAIWAN



SANDELASTED BLACK / METAL GREY

WEIGHT 2,105 GRAMS/PAIR
RIM TYPE 21MMx31.8MM

XD641SB

WEIGHT 192G
SEAL BEARING 2
SPOKE HOLES 32
GAUGE 14
O.L.D 110MM
AXLE 20x110MM
P.C.D 58MM
F.T.F 59.5MM
OFFSET 5.9MM



XD262SB

WEIGHT 370G BOLT ON 440G
SEAL BEARING 4
SPOKE HOLES 32
GAUGE 14
O.L.D 135
AXLE 14x135x145MM
P.C.D 62MM
F.T.F 72.9MM
OFFSET 0.6MM
PAWLS 6 42T



ROAD DISC

D791SB

WEIGHT 156G
SEAL BEARING 2
SPOKE HOLES 24/28/32/36
GAUGE 14
O.L.D QR/9/12/15*100MM
AXLE QRx108MM
P.C.D 58/45MM
F.T.F 62MM
OFFSET 7.7MM



E-MTB

D811SB-B15

WEIGHT 147G
SEAL BEARING 2
SPOKE HOLES 24/28/32/36
GAUGE 14
O.L.D 110MM
AXLE 15MM
P.C.D 45MM
F.T.F 72MM
OFFSET 7.2MM



D792SB

WEIGHT 274G
SEAL BEARING 4
SPOKE HOLES 24/28/32
GAUGE 14
O.L.D QR/10/12x135MM
AXLE QRx145/X12x142MM
P.C.D 58/49MM
F.T.F 56.4MM
OFFSET 7.4MM
PAWLS 4



D162SB-SL

WEIGHT SRAM425G 11S-457G
SEAL BEARING 2
SPOKE HOLES 28/32
GAUGE 14
O.L.D 148MM
AXLE 12x148MM
P.C.D 62/58MM
F.T.F 62.2MM
OFFSET 7.5MM
PAWLS 5





THE BEST CHOICE FOR YOUR WHEELS

KT patented driver engaged system enhance a comfortable race and efficient shifting without drag, affordable for powerful pedaling when sprinting.

MADE IN TAIWAN ONLY

6 PAWLS 12 CLICKS SYSTEM

- 6 pawls & 6 springs
- AL7075 or CrMo freehub body compatible w/Shimano 11sp & Campy 9, 10, 11sp cassette
- BMX one-piece driver, optional for 8T, 9T, 10T, 11T 1/8" & 3/32"

PATENT NO.

TW I252815
US 7121394B2
DE 202005000114.7

NL 1030207
CN 201031894Y
DE 202007005699.0

TECHNOLOGIES

X-12 For Rear Hub

Compatible with syntace X-12 system. Only change end cap to fit.



• IDØ11x135mm
• IDØ12x142mm

IDØ5.2x135x145mm

4 in 1 For Front Hub

Converter end cap from ID5.2 to ID12mm, 15mm, 4 in 1 exchangeable.



IDØ5.2mm

IDØ9mm

IDØ12mm

IDØ15mm

TECHNOLOGIES



Only change cassette body.

- 6 Pawl 102T
- 4 Pawl 4 Spring
- 3 Pawl 3 Spring



FOR MTB OR E-BIKE SELECTION

Anti Bite

Press-fit Cr-Mo plate into Alloy cassette body prevent from free wheel bite into.

- 6 Pawl 102T
- 4 Pawl 4 Spring
- 3 Pawl 3 Spring



Spline (for E-Bike)

High torque Spline press-fit ratchet ring, instead of threaded ratchet ring for E-bike.

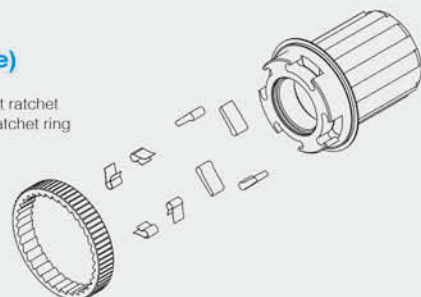

ROAD SERIES



QL-ZN1F

Spoke Hole: 14/16, 20
 Axle Dim.: IDø5.2x100x108mm
 Axle Material: AL7075
 Sealed Cartridge Bearings(SB): 2pcs
 Weight: 87g



QL-ZN1R



Spoke Hole: 14/20, 24
 Axle Dim.: IDø5.2x130x140mm
 Axle Material: AL7075
 Sealed Cartridge Bearings(SB): 4pcs
 Weight: 243g
 Freehub Body: AL7075 6 pawls 6 springs, compatible w/ Shimano or Campy 11sp cassette
 Option: AL7075 cassette body compatible w/Campy 11sp cassette: **QL-ZN1CR**



QL-2N9F

Spoke Hole: 14/16, 20
 Axle Dim.: IDø5.2x100x108mm
 Axle Material: AL7075
 Sealed Cartridge Bearings(SB): 2pcs
 Weight: 103g



QL-2NBF

Spoke Hole: 14/16, 20
 Axle Dim.: IDø5.2x100x108mm
 Axle Material: AL7075
 Sealed Cartridge Bearings(SB): 2pcs
 Weight: 100g



QL-4NAR



Spoke Hole: 14/20, 24
 Axle Dim.: IDø5.2x130x140mm
 Axle Material: AL7075
 Sealed Cartridge Bearings(SB): 4pcs
 Weight: 230g
 Freehub Body: AL7075 4 pawls 4 springs, compatible w/ Shimano or Campy 11sp cassette
(OE: QL-4NHR)



QL-2NKR



Spoke Hole: 14/20, 24
 Axle Dim.: IDø5.2x130x140mm
 Axle Material: AL7075
 Sealed Cartridge Bearings(SB): 4pcs
 Weight: 220g
 Freehub Body: AL7075 3 pawls 1 spring, compatible w/ Shimano or Campy 11sp cassette



QL-M88F

Spoke Hole: 14/20
 Axle Dim.: IDø5.2x100x108mm
 Axle Material: AL7075
 Flange PCD: 32mm
 Sealed Cartridge Bearings(SB): 2pcs
 Weight: 83g
(OE: QL-M8HF)



QL-ZL7R



Spoke Hole: 14/20, 24
 Axle Dim.: IDø5.2x130x140mm
 Axle Material: AL7075
 Flange PCD: L: 40 / R: 51mm
 Sealed Cartridge Bearings(SB): 4pcs
 Weight: 252g
 Freehub Body: AL7075 6 pawls 6 springs, compatible w/ Shimano or Campy 11sp cassette
 Option: AL7075 cassette body compatible w/Campy 11sp cassette: **QL-ZL7CR**
(OE: QL-ZH7R)



QL-4J7R



Spoke Hole: 14/20, 24, 28
 Axle Dim.: IDø5.2x130x140mm
 Axle Material: AL7075
 Flange PCD: L: 40 / R: 54mm
 Sealed Cartridge Bearings(SB): 4 pcs
 Weight: 245g
 Freehub Body: AL7075 4 pawls 4 springs, compatible w/ Shimano or Campy 11sp cassette
(OE: QL-4K7R)



QL-2K2F

Spoke Hole: 14/16, 20, 24
 Axle Dim.: IDø5.2x100x108mm
 Axle Material: AL7075
 Flange PCD: 32mm
 Sealed Cartridge Bearings(SB): 2 pcs
 Weight: 80g
(OE: QL-2VDF, 74g)



QL-2VBR



Spoke Hole: 14/20, 24
 Axle Dim.: IDø5.2x130x140mm
 Flange PCD: L:40 / R:49
 Sealed Cartridge Bearings(SB): 4pcs
 Weight: 233g
 Freehub Body: AL7075 3 pawls 1 spring, compatible 11sp cassette
 Option: AL7075 cassette body compatible w/campy 11sp cassette
(OE: QL-2VDR)



QL-GN1R

Spoke Hole: 14/24, 32
 Axle Dim.: IDø5.2x130x140mm
 Axle Material: AL7075
 Sealed Cartridge Bearings(SB): 2pcs
 Weight: 340g
 Freehub Body: Cr-Mo splined type 3 pawls, compatible w/ Shimano or Sram 11sp cassette

The most popular hub for all MTB system



6 PAWLS 18 CLICKS SYSTEM

6 pawls, 6 springs & 102 tooth
AL7075 or Cr-Mo freehub body compatible w/Shimano 11sp & Campy 9, 10, 11sp cassette / SRAM XX1.
BMX one-piece driver, optional for 8T, 9T, 10T, 11T 1/8" & 3/32".
DH, MTB, BOOST, E-BIKE...

DH, BOOST SERIES



QL-TW1F

4in1

EXCHANGEABLE CONVERTER CAPS

Spoke Hole: 14/32, 36
Axle Dim.: IDØ20x110mm
Axle Material: AL7075
Flange PCD: 58mm
Sealed Cartridge Bearings(SB): 2pcs
Weight: 210g
Option: Non-Disc **QL-PS3F**
Option: Center Lock: **QL-TL1F**
Option: IDØ15x110mm: **QL-TWEF** For Boost
Option: Center Lock: **QL-TLEF** For Boost (15x110mm)



QL-YZ5MR



Spoke Hole: 14/32, 36
Axle Dim.: IDØ12x150mm, IDØ12x157mm
Axle Material: AL7075
Flange PCD: 58mm
Sealed Cartridge Bearings(SB): 4pcs
Weight: 326g
Freehub Body: AL7075 6 pawls 6 springs, compatible w/
Shimano or Sram 11sp cassette
Option: Freehub body SRAM XD: **OE: QL-Y75XR**
Option: Ø17mm axle Center Lock:
OE: QL-Y45MR (Shimano) / QL-Y72XR (Sram)
(OE: QL-Y75MR Shimano / QL-Y75XR Sram)



QL-415MR



Spoke Hole: 14/32, 36
Axle Dim.: IDØ12x150mm, IDØ12x157mm
Axle Material: AL7075
Flange PCD: 58mm
Sealed Cartridge Bearings(SB): 4pcs
Weight: 317g
Freehub Body: AL7075 4 pawls 4 springs, compatible w/
Shimano or Sram 11sp cassette
(OE: QL-4H5MR)



QL-S3BF

Boost



Spoke Hole: 14/32, 36
Axle Dim.: IDØ5.2x110mm, IDØ15x110mm for Boost
Axle Material: AL7075
Flange PCD: 58mm
Sealed Cartridge Bearings(SB): 2pcs
Weight: 152g
Option: Converter end cap from ID5.2mm, ID12mm to
ID15mm
Option: IS6: **QL-S35F (OE: QL-S36F)**
Option: High-Low Flange: **QL-SLGF**
(OE: IS6: QL-8BFF Alloy axle, no CNC Disc)



QL-YZ2MR



Spoke Hole: 14/32, 36
Axle Dim.: IDØ12x148mm, IDØ5.2x148mm for Boost
Axle Material: AL7075
Flange PCD: 58mm
Sealed Cartridge Bearings(SB): 4pcs
Weight: 340g
Freehub Body: AL7075 6 pawls 6 springs, compatible w/
Shimano or Sram 11sp cassette
Option: Ø17mm axle Center Lock: **QL-Y42MR (Shimano)**
QL-Y42XR (Sram)
(IS6 Disc: OE: QL-Y72MR Shimano / QL-Y72XR Sram)



QL-4ABXR

Boost



Spoke Hole: 14/28, 32, 36
Axle Dim.: IDØ12x148mm, IDØ5.2x148mm for Boost
Axle Material: AL7075
Flange PCD: 58mm
Sealed Cartridge Bearings(SB): 4pcs
Weight: 295g
Freehub Body: AL7075 4 pawls 4 springs, compatible w/
Shimano or Sram 11sp cassette
Option: IS6 with Shimano driver: **QL-4AAMR**, 300g
IS6 with Sram XD driver: **QL-4AAXR**, 300g
(OE: QL-4HBMR Shimano / QL-4HBXR Sram)
(OE: QL-4H8MR Shimano / QL-4H8XR Sram)



QL-CN8F

Boost 4in1

Spoke Hole: 14/24, 28
Axle Dim.: IDØ15x110mm
Flange PCD: 40
Sealed Cartridge Bearings(SB): 2pcs
Weight: 135g
Option: Converter end cap from ID5.2mm, ID12mm to
ID15mm
Option: IS6: **QL-CN9F**



QL-YMHR



Spoke Hole: 14/24, 28
Axle Dim.: IDØ12x148mm
Flange PCD: R: 59.8mm, L: 39mm
Sealed Cartridge Bearings(SB): 4pcs
Weight: 296g
Freehub Body: AL7075 4 pawls 4 springs, compatible w/
Shimano or Sram 11sp cassette
Option: Center Lock: **QL-YMDMR**



QL-CM8MR



Spoke Hole: 14/24, 28
Axle Dim.: IDØ12x148mm
Axle Material: AL-7075
Flange PCD: R: 58mm, L: 40mm
Sealed Bearing: 4pcs
Weight: 284g
Freehub Body: AL7075 4 pawls 4 springs, compatible w/
Shimano or Sram 11sp cassette
Option: IS6 with Shimano driver: **QL-CM9MR**
IS6 with Sram XD driver: **QL-CM9XR**

MTB SERIES



QL-SL6F

4 in 1

Spoke Hole: 14/32, 36
 Axle Dim.: IDØ15x100mm
 Axle Material: AL7075-T6
 Flange PCD: L: 58 / R: 45mm
 Sealed Cartridge Bearings(SB): 2pcs
 Weight: 137g
 Option: Converter end cap from IDØ5.2mm, IDØ9mm, IDØ12mm to IDØ15mm
 Option: Center Lock: **QL-SL8F**
 Option: Same Dimension Flanges **QL-SL2F**
 (OE: **QL-8SHF, 157g**)



QL-YZ1MR

X-12



Spoke Hole: 14/28, 32, 36
 Axle Dim.: IDØ5.2x135x145mm, IDØ12x142mm
 Axle Material: AL7075, Ø15mm
 Flange PCD: 58mm
 Sealed Cartridge Bearings(SB): 4pcs
 Weight: 310g
 Freehub Body: AL7075 6 pawls 6 springs, compatible w/ Shimano or Sram 11sp cassette
 Option: Ø17mm axle Center Lock:
QL-Y41MR (Shimano) / QL-Y41XR (Sram)
 (IS6 Disc: OE: **QL-Y71MR Shimano / QL-Y71XR Sram**)



QL-4S1MR

X-12



Spoke Hole: 14/28, 32, 36
 Axle Dim.: IDØ5.2x135x145mm, IDØ12x142mm
 Axle Material: AL7075
 Flange PCD: 58mm
 Sealed Cartridge Bearings(SB): 4pcs
 Weight: 306g
 Freehub Body: AL7075 4 pawls 4 springs, compatible w/ Shimano or Sram 11sp cassette
 Option: Center Lock: **QL-4HCMR (Shimano) QL-4HCXR (Sram)**
 (OE: **QL-4HCMR Shimano / QL-4HCXR Sram**)



QL-9MCF

Spoke Hole: 14/24, 28
 Axle Dim.: IDØ15x100, 5.2x100x108, 9x100, 12x100mm
 Flange PCD: 40mm
 Sealed Cartridge Bearings(SB): 2pcs
 Weight: 140g
 Option: Converter end cap from IDØ5.2mm, IDØ9mm, IDØ12mm, IDØ15mm



QL-YMCMR

X-12



Spoke Hole: 14/24, 28
 Axle Dim.: IDØ5.2x135x145mm, IDØ12x142mm
 Flange PCD: L: 39 / R: 59.8mm
 Sealed Cartridge Bearings(SB): 4pcs
 Weight: 286g
 Freehub Body: AL7075 6 pawls 6 springs, compatible w/ Shimano 11sp or Sram XD cassette
 Option: IS6 with Shimano driver: **QL-YM1MR**
 IS6 with Sram XD driver: **QL-YM1XR**



QL-4MCMR

X-12



Spoke Hole: 14/24, 28
 Axle Dim.: IDØ5.2x135x145mm, IDØ10x135mm, IDØ12x135mm, IDØ12x142mm
 Flange PCD: L: 39 / R: 56.8mm
 Sealed Cartridge Bearings(SB): 4pcs
 Weight: 278g
 Freehub Body: AL7075 4 pawls 4 springs, compatible w/ Shimano 11sp or Sram XD cassette
 Option: IS6 with Shimano driver: **QL-4M1MR**
 IS6 with Sram XD driver: **QL-4M1XR**



QL-2L7F

4 in 1

Spoke Hole: 14/24, 28
 Axle Dim.: IDØ15x100mm
 Flange PCD: 40
 Sealed Cartridge Bearings(SB): 2pcs
 Weight: 125g
 Option: Converter end cap from ID5.2mm, ID9mm, ID12mm to ID15mm
 Option: Center Lock: **QL-2L9F**
 (OE: **QL-8LHF**)



QL-4L1MR

X-12



Spoke Hole: 14/24, 28
 Axle Dim.: IDØ5.2x135x145mm, IDØ12x142mm
 Axle Material: AL-7075
 Flange Pcd: L: 40 / R: 58mm
 Sealed Bearing: 4pcs
 Weight: 285g
 Freehub Body: AL7075 4 pawls 4 springs, compatible w/ Shimano 11sp or Sram XD cassette
 Option: Center Lock: **QL-4LLMR (Shimano) QL-4LLXR (Sram)**
 (OE: **QL-4LHMR Shimano / QL-4LHXR Sram**)



QL-SL2F

4 in 1

Spoke Hole: 14/32, 36
 Axle Dim.: IDØ15x100mm
 Axle Material: AL7075
 Flange PCD: 58mm
 Sealed Cartridge Bearings(SB): 2pcs
 Weight: 137g
 Option: Converter end cap from ID5.2mm, ID9mm, ID12mm to ID15mm
 Option: IDØ15x110mm center lock: **QL-S3BF**
 Option: Center Lock: **QL-SL1F**, Hi-Low Flange: **QL-SL8F**
 Option: Hi-Low Flange: **QL-SL6F (OE: QL-8SHF, 157g)**
 (OE: **QL-SH2F**)

ROAD DISC SERIES



QL-4W7F

4 in 1

Spoke Hole: 14/24, 28
 Axle Dim.: IDØ15x100mm, IDØ5.2x100x108mm, IDØ9x100mm, IDØ12x100mm
 Flange PCD: 40mm
 Sealed Cartridge Bearings(SB): 2pcs
 Weight: 115g
 Option: Converter end cap from IDØ5.2mm, IDØ9mm, IDØ12mm, IDØ15mm



QL-4W6MR



Spoke Hole: 14/24
 Axle Dim.: IDØ5.2x135x145mm, IDØ10x135mm, IDØ12x135mm, IDØ12x142mm
 Flange PCD: L: 40 / R: 58mm
 Sealed Cartridge Bearings(SB): 4pcs
 Weight: 248g
 Freehub Body: AL7075 4 pawls 4 springs, compatible w/ Shimano 11sp or Sram XD cassette



QL-4E1MR

X-12



Spoke Hole: 14/28, 32, 36
 Axle Dim.: IDØ5.2x135x145mm, IDØ12x142mm
 Axle Material: AL7075
 Flange PCD: 58mm
 Sealed Cartridge Bearings(SB): 4pcs
 Weight: 388g
 Freehub Body: Cr-MO 4 pawls 4 spring, compatible w/ Shimano 11sp cassette
 Option: IDØ12x142mm center lock: **QL-4BCMR**
 Option: IDØ12x148mm IS6 disc: **QL-4E2MR**
 Option: IDØ12x148mm center lock: **QL-4ECMR**

OE SERIES



QL-SD3F

4 in 1

Spoke Hole: 14/28, 32, 36
 Axle Dim.: IDØ5.2x100x108mm, IDØ12x100mm, IDØ15x100mm
 Axle Material: Alloy
 Flange PCD: 58 / 51mm
 Sealed Cartridge Bearings(SB): 2pcs
 Weight: 167g
 Option: Converter end cap from ID5.2mm, ID15mm
 Option: Center Lock: **QL-SC3F**
 Option: Without CNC Disc **QL-SS3F**



QL-4H4MR

X-12



Spoke Hole: 14/28, 32, 36
 Axle Dim.: IDØ5.2x135x145mm, IDØ12x142mm
 Axle Material: AL7075
 Flange PCD: 58mm
 Sealed Cartridge Bearings(SB): 4pcs
 Weight: 306g
 Freehub Body: AL7075 4 pawls 4 springs, compatible w/ Shimano or Sram 11sp cassette
 Option: Center Lock with Shimano driver: **QL-4HCMR**
 Center Lock with Sram XD driver: **QL-4HCXR**



QL-XD2R

X-12

Spoke Hole: 14/28, 32, 36
 Axle Dim.: IDØ5.2x135x145mm, IDØ12x142mm
 Axle Material: Cr-Mo
 Flange PCD: 58mm
 Sealed Cartridge Bearings(SB): 2pcs
 Weight: 430g
 Freehub Body: Cr-Mo threaded type 3 pawls, compatible w/Shimano 9, 10, 11sp cassette
 Option: Center Lock: **QL-XC2R**
 Option: Without CNC Disc **QL-XX2R**



QL-SD2F

Boost 4 in 1

Spoke Hole: 14/28, 32, 36
 Axle Dim.: IDØ5.2x110x118mm, IDØ12x110mm, IDØ15x110mm, IDØ20x110mm
 Axle Material: Alloy
 Flange PCD: 58 / 51mm
 Sealed Cartridge Bearings(SB): 2pcs
 Weight: 176g
 Option: Converter end cap from ID5.2mm, ID15mm
 Option: Center Lock: **QL-SC2F**
 Option: Without CNC Disc **QL-SS1F Boost**



QL-4H8XR

Boost



Spoke Hole: 14/28, 32, 36
 Axle Dim.: IDØ12x148mm, IDØ5.2x148mm for Boost
 Axle Material: AL7075
 Flange PCD: 58mm
 Sealed Cartridge Bearings(SB): 4pcs
 Weight: 295g
 Freehub Body: AL7075 4 pawls 4 springs, compatible w/ Shimano or Sram 11sp cassette
 Option: IS6: **QL-4HBMR Shimano / QL-4HBXR Sram**
 Center Lock: **QL-4HBMR Shimano / QL-4H8XR Sram**



QL-XD8R

Boost 11 SP

Spoke Hole: 14/28, 32, 36
 Axle Dim.: IDØ12x148mm, IDØ5.2x148x158mm
 Axle Material: Cr-Mo
 Flange PCD: 58mm
 Sealed Cartridge Bearings(SB): 2pcs
 Weight: 442g
 Freehub Body: Cr-Mo threaded type 3 pawls, compatible w/Shimano 9, 10, 11sp cassette
 Option: Center Lock: **QL-XC8R**
 Option: Without CNC Disc **QL-XX8R**

FAT BIKE SERIES



QL-TB1F

Spoke Hole: 14/28, 32, 36
 Axle Dim.: IDØ15x135mm, IDØ5.2x135x143mm
 Axle Material: AL7075-T6
 Flange PCD: 58mm
 Sealed Cartridge Bearings(SB): 2pcs
 Weight: 259g



QL-TB4F

Spoke Hole: 14/28, 32, 36
 Axle Dim.: IDØ15x150mm, IDØ5.2x150x158mm
 Axle Material: AL7075-T6
 Flange PCD: 58mm
 Sealed Cartridge Bearings(SB): 2pcs
 Weight: 278g
 Option: Center Lock: **QL-TC4F**



QL-4SAMR

Spoke Hole: 14/28, 32, 36
 Axle Dim.: IDØ5.2x190x200mm, 12x190mm, 12x197mm
 Axle Material: AL7075-T6
 Flange PCD: 58mm
 Sealed Cartridge Bearings(SB): 5pcs
 Weight: 374g
 Freehub Body: AL7075 4 pawls 4 springs compatible w/ Shimano 11sp and Sram
 Option: Sram XX1: **QL-4SAXR**
 Option: Center Lock: **QL-4CAMR**
 Option: IDØ12x170mm: **QL-4SDMR**

COSTER BRAKE SERIES



QL-307R-T

100% MADE IN TAIWAN ONLY

Spoke Hole: 14/36, 12/36
 Axle Material: Cr-Mo
 Flange PCD: 48.5mm
 Flange distance: 47.4mm
 Weight: 704g+94g (7 accessories)
 Surface: Chrome Plated (CP) or ED black



QL-3A8R

100% MADE IN TAIWAN ONLY
AL6061-T6 HUB BODY

Spoke Hole: 14/36
 Axle Material: Cr-Mo
 Flange PCD: 69mm
 Flange distance: 59mm
 Weight: 925g (7 accessories)
 Surface: Anodized color optional



ACCESSORIES (optional)



BMX SERIES

C04



QL-MH1F

Spoke Hole: 14/32, 36
 Axle Dim.: IDØ5.2x100x108mm
 Axle Material: AL7075
 Flange PCD: 58mm
 Sealed Cartridge Bearings(SB): 2pcs
 Weight: 234g
 Options: 3/8" solid axle: **QL-MH3F**
 Cr-Mo axle w/internal thread for M6 bolt:
QL-MHGF



QL-YKZR

Spoke Hole: 14/32, 36
 Axle Dim.: IDØ5.2x135x145mm, IDØ12x135mm
 Axle Material: AL7075
 Flange PCD: 58mm
 Sealed Cartridge Bearings(SB): 4pcs
 Weight: 337g
 Freehub Body: AL7075 6 pawls 6 springs, 1sp cog
 Option: Center Lock: **QL-YZCR**



QL-YKTR

Spoke Hole: 14/32, 36
 Axle Dim.: IDØ5.2x110x120mm
 Axle Material: AL7075
 Flange PCD: 58mm
 Sealed Cartridge Bearings(SB): 4pcs
 Weight: 325g
 Freehub Body: Cr-Mo 6 pawls 6 springs, 1sp cog
 Option: Internal Lock Ring: **QL-YKUR**



QL-Y29R

Spoke Hole: 14/36, 48
 Axle Dim.: M14 (Hollow ID5.2) x110x175, 180mm
 Axle Material: Cr-Mo
 Flange PCD: L: 51 / R: 53mm
 Sealed Cartridge Bearings(SB): 4pcs
 Weight: 480g
 Driver: 6 pawls 6 springs, one-piece forged driver (8, 9, 10, 11, 1/8") RHD
 Options: LHD driver: **QL-Y19R**
 RHD driver 3/8" solid axle: **QL-Y28R**



QL-Y25R

Spoke Hole: 14/32, 36
 Axle Dim.: M10 (Hollow w/internal thread M6) x110x120mm
 Axle Material: AL7075
 Flange PCD: L: 51 / R: 53mm
 Sealed Cartridge Bearings(SB): 4pcs
 Weight: 385g
 Driver: 6 pawls & 6 springs, forged cassette 1sp RHD
(OE: QL-625PR)



QL-X41R

Spoke Hole: 14/32, 36
 Axle Dim.: M14 (Hollow ID5.2) x110x175, 180mm
 Axle Material: Cr-Mo
 Flange PCD: L: 51 / R: 53mm
 Sealed Bearing: 4pcs
 Weight: 462g
 Driver: L3 + R3 with 6 spring, one piece forged driver
 BMX for 8T, 9T, 10T, 11T 1/8" & 3/32"
(OE: QL-X4AR)



TRACE SERIES



QL-3U8R

ONE-PIECE DRIVER
 Spoke Hole: 14/36
 Axle Dim.: 3/8"x110x175, 180mm
 Axle Material: Cr-Mo
 Flange PCD: 46mm
 Sealed Cartridge Bearings(SB): 3pcs
 Weight: 485g
 Driver: Forged one piece freecoaster driver (9T 3/32") RHD
 Options: M14 axle adaptor: **QL-3T8R**
 M14 through axle: **QL-391R**
 3/8" axle & 8T driver: **QL-3A8R**



QL-DF1F

Spoke Hole: 14/32, 36
 Axle Dim.: Hollow w/internal thread M9 x100mm
 Flange PCD: 38mm
 Sealed Cartridge Bearings(SB): 2pcs
 Weight: 120g (no bolt)



QL-DF1R

Spoke Hole: 14/32, 36
 Axle Dim.: Hollow w/internal thread M10 x120mm
 Flange PCD: 45mm
 Sealed Cartridge Bearings(SB): 2pcs
 Weight: 173g (no bolt)



QL-M74F

Spoke Hole: 14/20, 24, 28
 Axle Dim.: IDØ5.2x74x82mm
 Axle Material: AL7075
 Flange PCD: 32mm
 Sealed Cartridge Bearings(SB): 2 pcs
 Weight: 68g



QL-DF6F

Spoke Hole: 14/32
 Axle Dim.: 3/8"x100x140mm
 Axle Material: Cr-Mo
 Flange PCD: 62.5mm
 Sealed Cartridge Bearings(SB): 2pcs
 Weight: 274g
 Options: M9x1.0 solid axle: **QL-DQ9F**
 M9x1.0 hollow axle: **QL-DF2F**



QL-DF6R

Spoke Hole: 14/32
 Axle Dim.: 3/8"x120x165mm
 Axle Material: Cr-Mo
 Flange PCD: 62.5mm
 Sealed Cartridge Bearings(SB): 2pcs
 Weight: 383g
 Freehub: L: fixed gear / R: BC1.37x24T
 Cog options: 14, 16, 17, 18T
 Options: M10x1.0 solid axle: **QL-DQ9R**
 M10x1.0 hollow axle: **QL-DF2R**



THROUGH AXLE DYNAMO HUB



JH-KD5F

Boost 4in1

Weight: 456g
 Brake type: Disc Brake
 Axle Type: QR 15 / 12 / 5.2mm (one hub can be compatible with 3 different end cap)
 Flange Diameter: 66mm
 Spoke P.C.D: 58mm
 Spoke Holes: 28H / 32H / 36H
 O.L.D: 100mm; 110mm for Boost (JH-KD1F)
 Sealed Cartridge Bearing (SB): 2 PCS



JH-KC5F

Boost 4in1

Weight: 448g
 Brake type: Centerlock
 Axle Type: QR 15 / 12 / 5.2mm (one hub can be compatible with 3 different end cap)
 Flange Diameter: 66mm
 Spoke P.C.D: 58mm
 Spoke Holes: 28H / 32H / 36H
 O.L.D: 100mm; 110mm for Boost (JH-KC1F)
 Sealed Cartridge Bearing (SB): 2 PCS

ACCESSORY

4in1 For Front Hub

Converter end cap from ID5.2 to ID12mm, 15mm, 4 in 1 exchangeable



IDØ15mm & Ø12mm

IDØ5.2mm

CONVERTER KIT

for MTB front hub OLD 100mm to 110mm (Boost)



QR DYNAMO HUB



JH-KC6F

Weight: 405g
 Brake Type: Centerlock Brake
 Axle Type: QR
 Flange Diameter: 60mm
 Spoke P.C.D: 52mm
 Spoke Holes: 32H / 36H
 O.L.D: 100mm
 Sealed Cartridge Bearing(SB): 2PCS(6000)



JH-KD6F

Weight: 415g
 Brake Type: Disc Brake
 Axle Type: QR
 Flange Diameter: 66mm(Disc side) & 60mm
 Spoke P.C.D: 58mm(Disc side) & 52mm
 Spoke Holes: 32H / 36H
 O.L.D: 100mm
 Sealed Cartridge Bearing(SB): 2PCS(6000)



JH-KV6F

Weight: 395g
 Brake Type: V-Brake
 Axle Type: QR
 Flange Diameter: 60mm
 Spoke P.C.D: 52mm
 Spoke Holes: 32H / 36H
 O.L.D: 74mm / 100mm
 Sealed Cartridge Bearing(SB): 2PCS(6000)

~ K 1280

AC-6V3W

Kx6 Series / QR Dynamo Hub system
Kx5 Series / Thru Axle 15 & 12mm Dynamo Hub System

INTER-3 REAR HUB

The proliferation of bicycle commuters and the associated bike-sharing programs, have resulted in an upturn in demand for the various components specifically designed for the commuter bicycle market. None more so than high quality, performance-focused internal-gear hub systems.

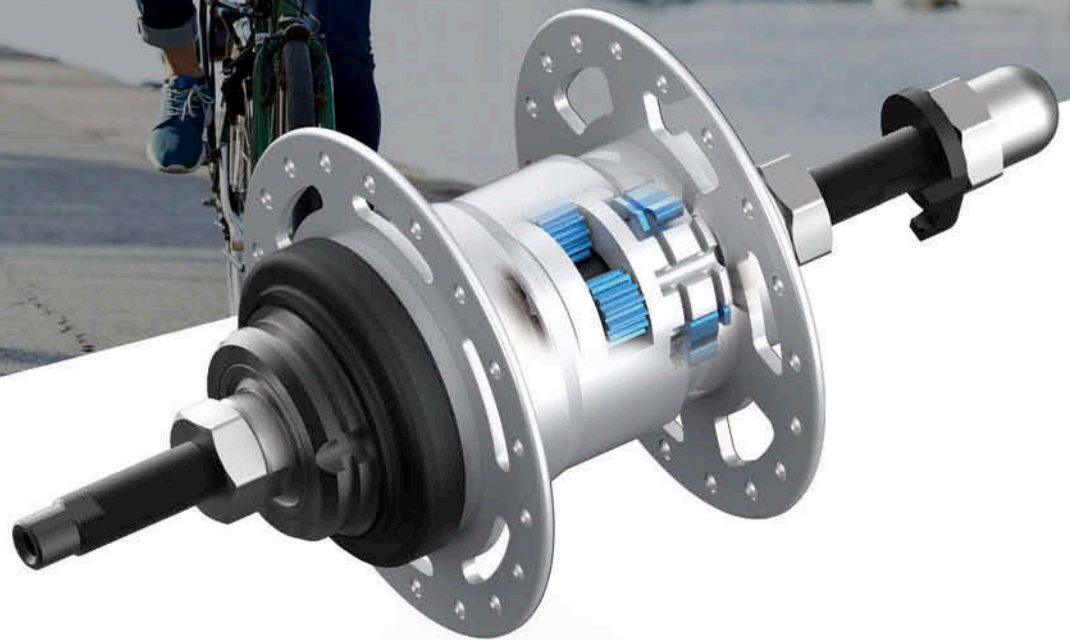

FR-H03R

Brake Type: V-Brake
 Color: Satin Silver
 Speeds: 3
 Gear Ratio: 0.733 / 1.000 / 1.360
 O.L.D: 120mm
 Spoke hole Size: 2.8mm
 Spoke Holes: 32H / 36H
 Axle Length: 181.6mm
 Flange Distance: 52.7mm
 PCD: L: 74.2 / R: 74.2mm
 Hub Shell Material: Steel
 Surface Finish: Painting
 Weight: 916g
 Sprocket: 14T, 16T, 18T, 19T, 20T, 22T

SPEED3

FR-H13R

Brake Type: Disc-Brake
 Color: Satin Silver
 Speeds: 3
 Gear Ratio: 0.733 / 1.000 / 1.360
 O.L.D: 135mm
 Spoke hole Size: 2.8mm
 Spoke Holes: 32H / 36H
 Axle Length: 181.6mm
 Flange Distance: 52.7mm
 PCD: L: 74.2 / R: 74.2mm
 Hub Shell Material: Steel
 Surface Finish: Painting
 Weight: 1035g
 Sprocket: 14T, 16T, 18T, 19T, 20T, 22T

SPEED3

FR-H23R

Brake Type: Drum-Brake
 Color: Satin Silver
 Speeds: 3
 Gear Ratio: 0.733 / 1.000 / 1.360
 O.L.D: 120mm
 Spoke hole Size: 2.8mm
 Spoke Holes: 32H / 36H
 Axle Length: 181.6mm
 Flange Distance: 52.7mm
 PCD: L: 74.2 / R: 74.2mm
 Hub Shell Material: Steel
 Surface Finish: Painting
 Weight: 977g (without drum brake)
 Sprocket: 14T, 16T, 18T, 19T, 20T, 22T

SPEED3



NAN HAI INDUSTRIAL CO., LTD

No. 58, Ho Hsing Rd., Houli District, Taichung City 42148, TAIWAN
 TEL: 886-4-25567147~8 FAX: 886-4-25574452
 Email: nanhai8@ms48.hinet.net
 www.nanhai-hubs.com



NH-992/993
 Sealed Bearing
 Spoke Hole: 28/32/36H
 992: 387g/993: 338g

NH-995/990/890
 990/995: Alloy Wheel Chair Tricycle
 890: Steel Wheel Chair Tricycle
 Spoke Hole: 20/28/32/36H

NH-991/790AA
 Sealed Bearing
 Spoke Hole: 20/28/32/36H



NH-1707WLTAR 286g
 Sealed Bearing
 Spoke Hole: 28/32/36H



NH-1701WLF
 Sealed Bearing
 Spoke Hole: 28/32/36H



NH-1704WLTAF
 Sealed Bearing
 Spoke Hole: 28/32/36H



NH-1705WLTAR
 Sealed Bearing
 Spoke Hole: 28/32/36H



NH-1802WLTAR
 Sealed Bearing
 Spoke Hole: 28/32/36H



NH-1801WLTAF
 Sealed Bearing
 Spoke Hole: 28/32/36H



NH-2050R 196g
Sealed Bearing
24H, O.L.D.: 130mm
Axle: 140mm

NH-2050F 94g
20H, O.L.D.: 100mm
Axle: 108mm

NH-2051R 220g
Sealed Bearing
24H, O.L.D.: 130mm
Axle: 140mm

NH-2051F 94g
20H, O.L.D.: 100mm
Axle: 108mm

NH-2001R /2001F (4 Sealed)
Spoke Hole: (F) 18/20/24H, (R) 24H
Axle Dim: (F) Φ 9x100x110mm
(R) Φ 10x130x140mm
Flange PCD: (F) 35mm, (R) 39-50,57mm
Weight: (F) 103g, (R) 221g



NH-2005SR 233g/**2005UF** 74g/**2005SF**
Sealed Bearing
Spoke Hole:20/28/32H

NH-2006R 337g/**2006F** 127g
Sealed Bearing
Spoke Hole:20/28/32/36H

NH-2003R 380g/**2007F** 134g
Loose Ball
Spoke Hole:20/28/32/36H



NH-190R/150F (4 Sealed)
Spoke Hole : 32/36H
Axle: (F)M15x150mm
(R)M12x190/197mm
Flange P.C.D. : 58mm
Weight: (F) 230g (R) 339g

NH-2000SR 377g/**2000SF** 195g
Sealed Bearing
Spoke Hole: 32/36H

NH-2000RSA 446g/**2000FSA** 255g
Loose Ball
Spoke Hole: 32/36H



NH-2008R /2008FQR(LOOSE BALL)
Spoke Hole : 20/28/32/36H
O.L.D.: (F) 72,75mm/ (R) 135mm
Axle Length: (F) 110/115/120/125mm
(R) 145mm

NH-1607TAR/1601TAF
Sealed Bearing
Spoke Hole: 28/32/36H

NH-2002R-M12 (4 Sealed)/2002F-M15
Spoke Hole : 24H
O.L.D.: (F) 100mm (R) 135mm
Axle Length: (F) 108mm (R) 145mm
Weight: (F) 174g (R) 292g



NH-745RQR/745FQR
Loose Ball
Spoke Hole: 20/28/32/36H

NH-745R/745F
Loose Ball
Spoke Hole: 20/28/32/36H

NH-766R/765F
Loose Ball
Spoke Holes: 20/28/32/36H



NH-762RQR/761FQR
Loose Ball
Spoke Holes: 20/28/32/36H

NH-724R/739F/703F
Steel Hub
Spoke Holes: 14Cx36H

NH-752-1R/713-1F
752-1R Cold Forged Rear Hub
Spoke Holes: 14Cx36H/12Cx36H



NH-722AS-M12: M12XP1.5X165B
NH-722AS-M14: M14XP1.5X145B
NH-7DQ-M10: M10X148.5
NH-7BQ-M9: M9X112MM

NH-795AS-M15/795AS-M12
M15XP1.5X150BX159A
M12XP1.5X121.5BX130.5A

NH-794A/792A/794D/792D
Alloy Lever Axle is CR-MO or Titanium
Axle: (F) M5x109/112/115mm
(R) M5x144/148.5/152mm



NH-794/792/794AS/792AS/793/791
794: Steel lever, M5x139/143/148.5mm
792: Steel lever, M5x103/109/112mm
794AS: Alloy lever, M5x139/144/148/151.5mm
792AS: Alloy lever, M5x109/112/115mm
793: M10x136/140/145mm
791: M9x108mm

NH-301/302/307/308/305/306/317/318
301: Front hub cone 5/16"
302: Rear hub cone 3/8"
307: Front hub cone QR M9
308: Rear hub cone QR M10
305: Front nut and washer 5/16 X26T
306: Rear nut and washer 3/8 X26T
317/318: Anti-scratching heavy load nut, M9/M10, 3/8"26T

NH-310/314/312/309/316/311
NH-310: Rear Flange cap 3/8"
NH-309: Front Flange Cup 5/16
NH-314: Rear Hub Cup 3/8"
NH-316: Rear Hub Cup, 29.3, 29.5mm
NH-312: Rear Hub Cup 3/8"
NH-311: Front Hub Cup 5/16"



neco

Professional Bike
Parts Manufacturers

NECO TECHNOLOGY INDUSTRY CO., LTD

www.necoparts.com



MS03F / MS03R

HUB SHELL	Alloy
AXLE MATERIAL	CR-MO
SEALED BEARING QTY	F:2 / R:4
OLD	F: 100mm / R: 135mm
PCD	58mm
SPOKE HOLES	14G×20H/24H/28H/32H/36H
WEIGHT	F: 274g / R: 353g
FINISH	Silver & Black



MS08F / MS08R

HUB SHELL	Alloy
AXLE MATERIAL	CR-MO
SEALED BEARING QTY	F:2 / R:4
OLD	F: 100mm / R: 135mm
PCD	58mm
SPOKE HOLES	14G×20H/24H/28H/32H/36H
WEIGHT	F:210g / R: 341g
FINISH	Silver & Black



MS641F/MS641R

HUB SHELL	Alloy
AXLE MATERIAL	CR-MO
ROLLING SYSTEM	Loose Ball
OLD	F: 100mm / R: 135mm
PCD	F: 38mm / R: 45mm
SPOKE HOLES	14G×20H/24H/28H/32H
WEIGHT	F: 155g / R: 245g
FINISH	Black / Silver / Blue / Golden



MS3951F/MS3951R

HUB SHELL	Alloy
AXLE MATERIAL	CR-MO
ROLLING SYSTEM	Loose Ball
OLD	F: 100mm / R: 135mm
PCD	F: 58mm / R: 58mm
SPOKE HOLES	14G×20H/24H/28H/32H
WEIGHT	F: 270g / R: 475g
FINISH	Black / Silver / Blue / Golden

Rove (NECO3-1+NECO4+RECTIFIER) Dynamo Hub Power Generator-UPS System

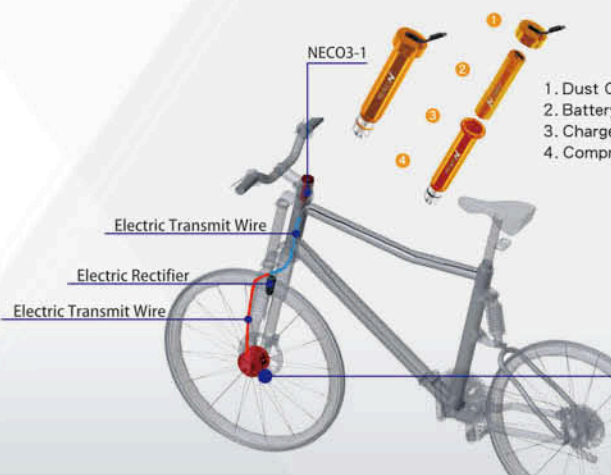

1. Dust Cover
2. Battery
3. Charger
4. Compression Plug



NECO4
Patent No.China : 5257748
5V-2A=10W
Global Maximum Bicycle
Dynamo Generator





Differential & Axle

Differential & Axle Components:

- Differential Models:**
 - DG72N: Weight: 542g, Size: 66mm*102mm
 - DG72NJT: Weight: 595g, Size: 66mm*102mm
 - ETGN: Weight: 410g, Size: 86*81mm
 - ETG DML: Weight: 453g, Size: 86mm*101mm
 - DG72NCS: Weight: 629g, Size: 66mm*131mm
 - ETGCS: Weight: 566g, Size: 60mm*98mm
 - DG72C HD (heavy duty): \varnothing 25mm axle
- Axle Models:**
 - UN Axle
 - HO Axle
 - SH-01
 - HO AXLE \varnothing 19mm
 - UN AXLE \varnothing 15mm & 17mm
 - \varnothing 25mm HO AXLE HD
- Adapters & Connectors:**
 - UJ-01
 - UJ-02 for FD HUB
 - UJ-02 for HD HUB
 - UJ-03-DHB 159 double head adapter for CS type differential
 - UJ-04-DM-HCW
 - UJ-05 CS132
 - HD adapter
- Hubs & Axle Assemblies:**
 - FD-HUB 36H
 - FD-HUB 36H
 - FD-HUB 36H
 - NUJ-FD axle
 - NUJ-HC axle
 - Axle Stopper
 - FD-HUB HD 36H & 48H
- Freewheels:**
 - SS22, 24, 26AR 7 speed freewheel
 - one speed freewheel
- Other Components:**
 - Lonely axle FDHUB
 - Lonely axle HC for HCWS



HARD CORE WHEEL

HC-5



20" (406) 24" (507) 26" (559) 27.5" (584)
HC-5 20" (406) HC-5 24" (507) HC-5 26" (559) HC-5 27.5" (584)

HC-3



16" (305) 20" (406) 24" x 1-3/8 (540)
HC-3 16" (305) HC-3 20" (406) HC-3 24" x 1-3/8 (540)

RIM FEATURES

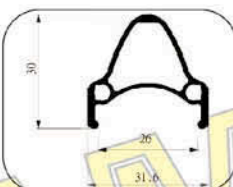
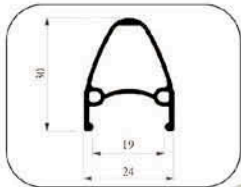

20" 24" 26" 27.5" RIM 20" (406) WD RIM

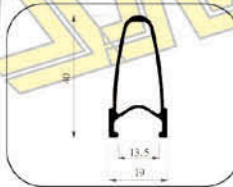
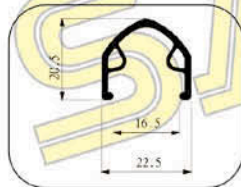

16" 305 RIM 24" (540), 700C RIM

AXLE FEATURES



HC 100F-SA DB



HC 135R-SA DB



HC 100F



HC-135R



HC TRI



HC-TRI
Ø 15mm axle
Ø 20mm axle



HC 100F-DB



HC 135R-DB

HC-5 700C (622) for FIX GEAR



HUB FEATURES



FRONT HUB

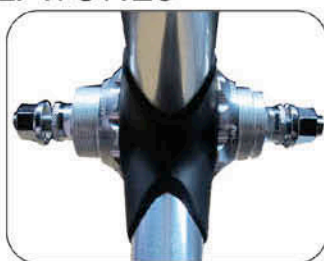

REAR HUB



FASTACE PERFORMANCE

ROAD



DH870FAS



DH870RASNY



RH613FAS



RH613RASNY



RH631FAS



RH631RASNY



RA213FAS



RA213RASTE

MTB



DH868FAS



DH868RASNY



DL812FCS



DL812RCSNS



DL829FAS



DL829RASNS



DA209RCSTX



DA211RCSTE

BMX



XE169RAS9T



XE158RASGH



XH860FAS



XH861RASNE



XS936FAS



XS936RAS



XL801RASNA

Tel : 886-4-26110058 Fax : 886-4-26112737

E-mail : sales@fastace.com.tw

台中市清水區臨港路7段303號

 303, Sec. 7, Lingang Rd., Qingshui Dist.,
Taichung City 436, Taiwan

MTB ROAD

DS901FAS



DS901RASTE

FOLDING

WH807FBS



WH807RASNV



WH825RASNU



WH827RUSNU

ACCESSORIES

HENSAS06



HENMAS03



HMNMA04



HENMAS07



HCGMSS02(STEEL)

 HSYMCS01
(Sealed bearing)

HENEAS01



HENBAS01(ALLOY)



Single Speed Freewheel 1/2"x1/8"

Material : Cr-Mo

Thread : B1.37 x 24

Finish : BLK / CP

Available : 16T ~ 18T



Single Speed Freewheel 1/2"x1/8"

Material : Steel

Thread : M30 x P1.0

Finish : BLK / CP

Available : 13T ~ 16T

FAST ACE



fastace.com



DC-R33

holes	32/36H
spec	M10*135W/M12*135W/M12*142W axle AL7075, disc
FREE BODY	6 pawls alloy shimano 8-11S cassette, 54T ratchet, 108 clicks, Sram XD free body available
Flange PCD	62mm
s.bearing	5
Weight/g	321



DC-R34

holes	32/36H
spec	M12*148W, axle AL7075, disc
FREE BODY	6 pawls alloy shimano 8-11S cassette, 54T ratchet, 108 clicks, Sram XD free body available
Flange PCD	62mm
s.bearing	5
Weight/g	328



XDC-F06

holes	24H
spec	M9*100W/M15*100W
FREE BODY	X
s.bearing	2
Weight/g	145



XDC-R06

holes	24H
spec	M10*135W/M12*142W
FREE BODY	3 pawls alloy shimano 11S cassette, W/washer for 10 speed
s.bearing	4
Weight/g	255



XRC-R08

holes	24H
spec	M10*130W
FREE BODY	3 pawls alloy shimano 11S cassette, W/ washer for 10 speed, campy free body available
s.bearing	4
Weight/g	231

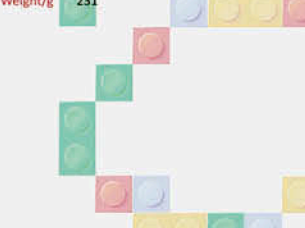

RC-R40

holes	24H
spec	M10*130W
FREE BODY	3 pawls alloy shimano 11S cassette, W/washer for 10 speed, campy free body available
s.bearing	4
Weight/g	244

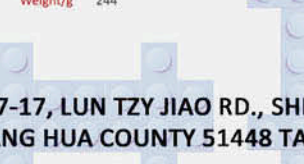

XRC-R09

holes	24H
spec	M10*130W
FREE BODY	3 pawls alloy shimano 11S cassette, W/washer for 10 speed, campy free body available
s.bearing	4
Weight/g	225



XRC-F09

holes	20H
spec	M9*100W
FREE BODY	X
s.bearing	2
Weight/g	82



CL-F27

holes	24H
spec	M9*100/M12*100/M15*100W
FREE BODY	X
s.bearing	2
Weight/g	147
Center lock	



CL-R27

holes	24H
spec	M10*135W/M12*142W
FREE BODY	6 pawls alloy shimano 11S cassette, 36T ratchet, 72 clicks, W/washer for 10 speed
s.bearing	4
Weight/g	285
Center lock	

YU HUB INDUSTRY

TEL+886-4-8811738/9
FAX+886-4-8812386
info@wheelmate.com.tw

NEW

NEW PRODUCT

www.yuhub.com.tw



MTB



XDC-F05

holes 32H
spec M9*100/M15*100W
FREE BODY X
s.bearing 2
Weight/g 180



XDC-R05

holes 32H
spec M10*135/M12*142W
FREE BODY 3 pawls alloy shimano 11S cassette
s.bearing 4
Weight/g 310



XDC-F03

holes 28H
spec M9*100/M15*100W
FREE BODY X
s.bearing 2
Weight/g 130



XDC-R03

holes 32H
spec M10*135/M12*142W
FREE BODY 3 pawls alloy shimano 11S cassette
s.bearing 4
Weight/g 300



XDC-F04

holes 32H
spec M15*110W
FREE BODY X
s.bearing 2
Weight/g 190
Boost MTB



XDC-R04

holes 32H
spec M12*148W
3 pawls alloy shimano 11S cassette
s.bearing 4
Weight/g 320
Boost MTB



XDC-F07

holes 24H
spec M15*110W
FREE BODY X
s.bearing 2
Weight/g 162
Boost MTB



DC-F27

holes 32H
spec M15*110W
FREE BODY X
Flange PCD 58/45mm
s.bearing 2
Weight/g 144
Boost MTB



XDC-R07

holes 28H
spec M12*148W
FREE BODY: 3 pawls alloy shimano 11S cassette
s.bearing 4
Weight/g 263
Boost MTB

DC-R27

holes 32H
spec M12*148W
FREE BODY 3 pawls alloy shimano 8-11S cassette, 5ram 11S available
Flange PCD 58/58mm
s.bearing 4
Weight/g 294
Boost MTB



NO 17-17, LUN TZY JIAO RD., SHI HWU,
CHANG HUA COUNTY 51448 TAIWAN

www.yuhub.com.tw



YU HUB INDUSTRY



TEL+886-4-8811738/9
 FAX+886-4-8812386
 info@wheelmate.com.tw

NEW NEW PRODUCT

www.yuhub.com.tw

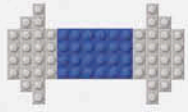

BMX RACING



BR-R03

holes 32/36H
 spec M10*110W, axle alloy, with M10*P1.5*30L bolt
 FREE BODY 6 pawls alloy shimano 15 cassette, 54T ratchet, 108 clicks, W/16T cog
 Flange PCD 45/62mm
 s.bearing 4
 Weight/g 408
 disc for BD-R03



BR-03F

adaptor for M20*100W

holes 36H
 spec M10*100W
 Flange PCD 47mm
 s.bearing 2
 Weight/g 224



FIX GEAR



FA-01F

holes 24H
 spec M9*100W*140L
 s.bearing 2
 Weight/g 198



FA-01R/FA-02R

holes 24H
 spec M10*120W*166L
 FREE BODY fix+fix
 s.bearing 2
 Weight/g 223
 FA-02R for fix/free thread

FREEWHEEL

- Fast engagement
- Forged crmo material



TRIAL FREEWHEELS

TFW-135.9B

spec 9pawls-16/17/18 tooth, ED finished sealed bearing
 Weight/g 175
 REMARKS 135 clicks

SHIMANO SPLIND FOR ITEM NO.: SFW-135.9 (Weight 170g)
 Titanium material available (Weight 118g)



BMX RACING FREEWHEEL

90.6B

spec 6pawls-16tooth, ED finished alloy and crmo material available sealed bearing
 Weight/g 143
 REMARKS 90 clicks



BFW-F9-108B

spec 9pawls-16/17/18 tooth, ED finished sealed bearing
 Weight/g 177
 REMARKS 108 clicks

NO 17-17, LUN TZY JIAO RD., SHI HWU,
 CHANG HUA COUNTY 51448 TAIWAN

www.yuhub.com.tw



POWERWAY

POWERWAY INDUSTRIAL CO., LTD.

No.43-7, Tianxin, Yuanli Town, Miaoli Country 358, Taiwan

Tel : +886-37-860570 Fax : +886-37-860575

Email : hinhin@ms45.hinet.net



R51 ROAD
O.L.D : 100/130mm



R36 ROAD
O.L.D : 100/130mm



R60 ROAD
O.L.D : 100/130mm



R12 ROAD
O.L.D : 100/130mm



R13 ROAD
O.L.D : 100/130mm



BOOST
O.L.D : F-110/R-148mm
End cap : F-M15,R-M12



M71 MTB
O.L.D : 100/135mm
End cap changeable



M82 BOOST
O.L.D : F-110/R-148mm
End cap : F-M15,R-M12



M74 FAT BIKE
O.L.D : F-135/R-191mm
End cap changeable



CT31 CENTER LOCK
O.L.D : 100/135mm
End cap changeable

center lock rotor mounting system licensed by Shimano

PATENTED ALLOY SPOKE





遠鋁工業股份有限公司

YUAN HONG BICYCLE PARTS CO., LTD.

No.37, Dingpi, Dapi Township, Yunlin-County 63144, Taiwan

Tel: 886-5-5916855 FAX: 886-5-5916635

E-mail: shen@yh-motoo.com



433028

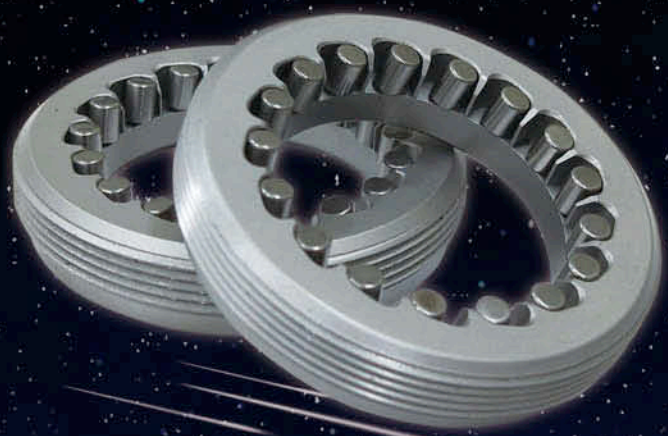

431727

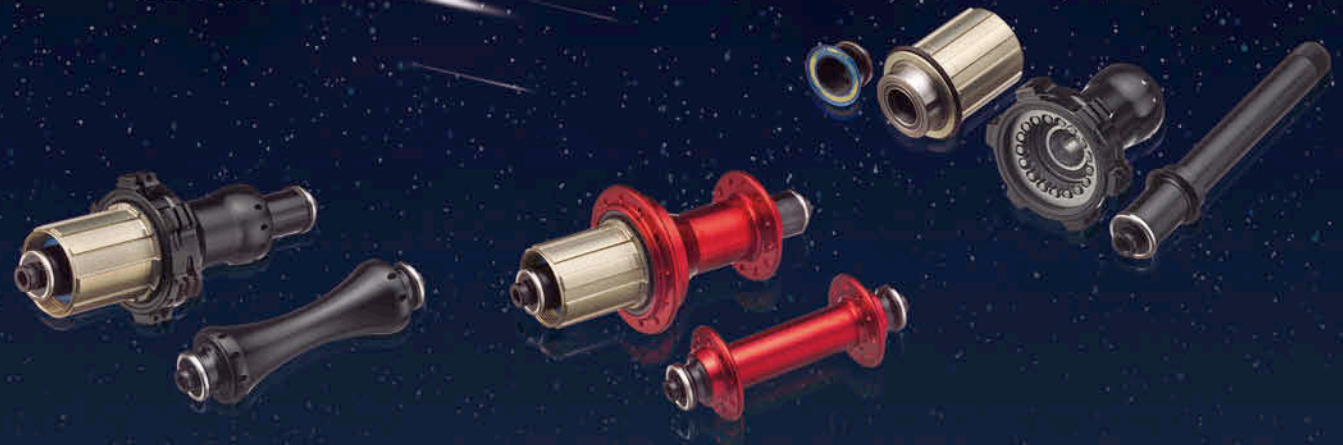

New Hub Innovative Technology.

- 1. 360 degree full-coverage bite. (breakthrough no tooth ratio)
- 2. 360-degree full-empty clutch idle.
(smooth idling speed is slow, speed is fast)
- 3. Break the traditional hub structure, new structure invention patent.
(Through multiple patents.)
- 4. System performance, high output, low friction, stable torque.

DATI

Design Accurate Technology i deal

HUB
www.datibike.com

MTB



DA-XI
259g



DA-M5-F
126g



DA-M4-F
178g



DA-M5R
240g



DA-M4R
279g



DA-M6-F 130g



DA-M6R 250g



ROAD



DA-VIGGER
185g



DA-R1-F
100/74
66g



DA-R2-F
76g



DA-R1-R
191g



DA-R2-R
223g



DA-AERO-F
65g



DA-R4-F
73g



DA-S1-F
284g



DA-AERO-R
200g



DA-R4-R
191g



DA-S1-R
335g

BUNGARUS-LINK

Bungarus-link is constructed by small pieces of alloy housing together with connectors. It's appearance just like Bungarus's spine structure and skin. The main concept is coming from Bungarus's sharp and smooth.

Product introduction:

- New Innovative Design: small pieces of alloy housing connected with POM connectors. Unique and smooth.
- Superlight Weight: 18g/1 meter.
- Perfect for internal routing
- No inner tube design



AICAN

www.aicanbike.com
aican.bicycle@gmail.com

GRUPO WEILICO, Co., Ltd. NO.38-2, YAXIU 3RD RD., DAYA DIST., TAICHUNG CITY 428, TAIWAN

TEL:+886-4-25686030

FAX:+886-4-25680862

datibike@gmail.com



ISO 9001 APPROVED

立翰

RIM MASTER INDUSTRIAL CO., LTD.
 No. 11, KAI FA 5TH RD, PAO AN TSUEN,
 REN DER HSIANG, TAINAN CITY, 717 TAIWAN.
 TEL: 886(6)2663521-3 FAX: 886(6)2660065
 E-mail: rimtr@ksts.seed.net.tw
 http://www.rimmaster.com.tw



BICYCLE TIRE VALVES



BICYCLE TIRE VALVES



VALVES FOR MOPED, MOTOR-CYCLE, SCOOTER AND CART TIRES



BICYCLE TIRE VALVES



BICYCLE TIRE VALVES



VALVES FOR MOPED, MOTOR-CYCLE, SCOOTER AND CART TIRES



VALVES FOR TRUCK, BUS, TRACTOR AND EM-TIRE



TUBELESS TIRE (SNAP-IN) VALVES

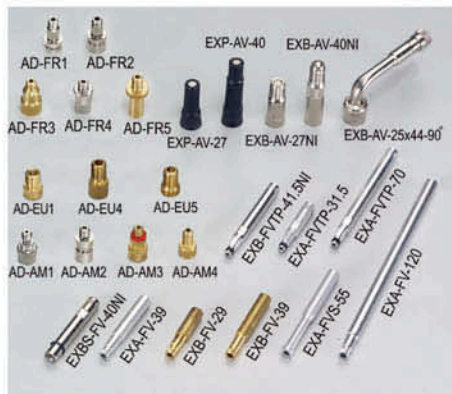

ADAPTOR & EXTENSION



TOOL & INDUSTRIAL VALVES



CAPS & EASY PUMP

TIRE VALVE

TUBELESS VALVE & ACCESSORIES

PROFESSIONAL
PRODUTOR For
GLOBAL Markets



1. Bicycle - MTB & ROAD, RACING

1-1 Presta TYPE (French) Colorful

- ✓ DJ720AL38 ✓ DJ720AL45
- ✓ DJ720AL60 ✓ DJ720AL80
- ✓ DJ720AL100



1-2 Extension

- ✓ FXAL40 ✓ FXAL80
- ✓ FN22AL ✓ FN30AL



1-3 Schrader TYPE (American) Colorful

- ✓ DJ455AL



2. Accessories

- ✓ Cores
- ✓ Caps
- ✓ Nuts
- ✓ O-ring

3. TPMS VALVE FOR BIKE

- ✓ IT'S UNDER PROCESSING
- ✓ DO WELCOME YOUR JOINT TO DEVELOP
- ✓ THESE NEW TPMS VALVES FOR BIKES

Supply Various Bike Valves,
Presta Tubeless Valve, Schrader Tubeless
Valve, etc.

Top-one Bike Valves Manufacturer, Our Expe-
rience is Worth Your Trust, Contact Us!

We are Global Market Leader in Bike Valve,
Road Bike Valve, MTB Valve, Visit Us!



TEL: 886-7-6951569
FAX: 886-7-6952370
E-mail: ytcentco@ms66.hinet.net
http://www.taiwanvalve.com/
http://www.tan.com.tw
Y.T. Chen Enterprise Co., Ltd.
No. 16, Lane 279, Taiping Road, Luju
Dist. Kaohsiung City 82142, Taiwan



CHIN CHANG PLASTIC INDUSTRY CO., LTD.

No.23, Dawei Rd., Dali District, Taichung, Taiwan.

TEL: 886-4-24064852 . 24067688 FAX: 886-4-24062579

E-mail:a4062579@seed.net.tw / service@chinchang.com.tw

http://www.chinchang.com.tw

Bicycle Wheel



Model:CC-260 Unicycles

Size: 14", 16", 18", 20"

Material:PP or Nylon

PU Tire,Air Tire

Model:CC-260

Size:12", 14", 16", 18", 20"

Material:PP or Nylon+FRP

PU Tire, Air Tire



Model:CC-223S

Size: 12"

Material: PP or Nylon

Air Tire



Model:CC-261

Size: 8"

Material:PP

EVA Tire



Model:CC-271

Size: Nylon 8"

Material: Nylon

Air Tire



Model:CC-224

Size: 10"

Material:PP

EVA Tire ,Air



Model:CC-266-2

Size:12"

Material: PP or Nylon

PU Tire,Air Tire



Bicycle Wheel



Model:CC-226

Size: 16"
Material: PP
Air Tire, EVA Tire
Coater brake available



Model:CC-228

Size:20"
Material: PP or Nylon+FRP
Air Tire
Coater brake available

Model:CC-221

Size: 12"
Material:PP
Air Tire, EVA Tire



CC-221D
Fixed cog

CC-221B
Freewheel type

CC-221C
Coater brake type

CC-221A
For Scooter



Model:CC-261

Size: 8"
Material:PP
EVA Tire



Model:CC-233

Size: 2.5" / 2.8-4"
Material: PP

Model:CC-230

Size: 8"
Material: Nylon, EVA Tire
Outer diameter:200mm



Model:CC-263A

Size: 165 x 37
Solid Rubber Tire



Model:CC-287

Size: 4" 300-4
Material: PP
Air Tire



Model:CC-286

Size: 6" 400-6
Material: PP
Air Tire



Model:CC-258

Chainwheel Cover
Material: PP

CHIN CHANG

www.chinchang.com.tw

Taiwan Bicycle Source 2018-2019



CHUN SHING ENT CO.,LTD

No.10, Shanjiao Ln., Jianmin Rd., Dali Dist., Taichung City 412, Taiwan

Tel: +886-4-24911759 Fax: +886-4-24912163

E-mail: song3300330@gmail.com/ song3300330@yahoo.com.tw

Executive: Hsieh Chen Pin



Model: 001A

Size: 14", 16", 18", 20"

Material: pp Impact And Weather-resistant

FRP PU Tire, Air Tire

For Unicycle



Model: 005

Size: 8"+7", 8"+8"+10"+8", +10"+7", 12"+7"

Material: PP and EVA Tire

For Unicycle, cart



011A

011B

011C

011D

Model: 011A, 011B, 011C, 011D

Size: 20"

Material: PP impact and weather-resistant

For caliper and coaster brake bikes



002A

002B-2

002B-3

Model: 002A, 002B

Size: 12", 14", 16"

Material: PP and EVA Tire

For BMX and Scooter



008

008-1

Model: 008, 008-1

Size: 14", 16", 18", 20"

Material: PP and EVA Tire

FRP PU Tire, Air Tire

For BMX and Scooter



014A

014B

014C

014D

Model: 014A, 014B, 014C, 14D

Size: 12", 14", 16"

Material: PP impact and weather-resistant

For caliper and coaster brake bikes, tool cabinet



012



Crank set

Model: 012

Size: 8", 9.5, 10", 12", 14", 16"

Material: EVA Tire

For Bicycle

536



015A

015B

015C

Model: 015A, 015B, 015C

Size: 12"

Material: EVA, PP/air tire

For BMX and Scooter



2"~8" CASTERS



12"~24" COMPOSITE WHEELS



5"~8" CASTER SETS

12"~26" SPOKED WHEELS



HUB TYPE



Specialized in developing and manufacturing all kinds of flexible and rigid PU foam products, vacuum foam system, PU integral foam, HR foam, Elastomers, Gel, Wood Imitation are available from choice.



OEM & ODM orders are welcome

LEAD SINCE



- LS-V601**
PU Vacuum foamed Recumbent seat & rest; Plywood base w/T-nuts
Seat:290x405x64mm
Rest:425x365x70mm
Vinyl top
- LS-V602**
PU Vacuum foamed Recumbent seat & rest; Plywood base w/T-nuts
Seat:280x395x64mm
Rest:485x385x83mm
Vinyl top
- LS-623**
PU foamed Recumbent seat & rest; W/thin plywood leathered cover; Plywood base w/T-nuts
Seat:500x450x65mm
Rest: 450x350x75mm
Vinyl top
- LS-AF002**
PU foamed Recumbent seat & rest; W/thin plywood leathered cover; Plywood base w/T-nuts
Seat:310x420x60mm
Rest:495x405x65mm
Vinyl top
- LS-AE001**
Recumbent seat & rest; HR foam w/EM cover ; Plywood base w/T-nuts
Seat:305x475x70mm
Rest:485x370x104mm
Vinyl top
- LS-R01**
PU one-piece design seat Steel tube base
385x475x60mm
- LS-R02**
PU Self-Skinning Foam, One-piece design Seat
Size: 400x410x190 (T:72)mm



- LS-V04**
PU vacuum foamed seat Steel plate base w/3 bolts
280x285x55mm
Vinyl top
- LS-V06**
PU vacuum foamed seat Steel plate base w/3 bolts
230x295x65mm
Vinyl top
- LS-V10**
PU vacuum foamed seat Steel plate base w/3 bolts
330x320x68mm
Vinyl top
- LS-V08**
PU vacuum foamed seat Steel plate base w/3 bolts
274x260x58mm
Vinyl top
- LS-B40**
PU integral foamed, plywood base w/T-nuts
Size:260x320x60m/m
- LS-B41**
PU integral foamed, plywood base w/T-nuts
Size:290x310x65m/m



- LS-B20**
Unicycle Saddle
Size: 324x127x55mm
PU self-skinning foam, W/Metal base W/seat post;O.D.:22.2mm or W/steel rails W/clamp
Tube length:180mm(7")
- LS-284**
MTB Saddle 292x165mm
EM top w/HR foam, Molded plastic base; W/steel rails W/clamp
- LS-05**
PU roller pad; Integral foam
Size: 200x102mm (ID:1")
- LS-08**
PU roller pad; Integral foam
Size: 178x102mm (ID:1")
- LS-AF003**
PU Vacuum Foam Seat; W/sponge leather; W/plastic base
Size: 620x330x140mm
- LS-E29**
Rower Seat; PU integral foam Plywood base w/ T-nuts
Size: 270x380x46mm



- LS-W264**
PU Solid tire 320x100mm
- LS-W260**
PU Solid tire 260x85mm
- LS-W253**
PU Solid tire 210x64mm
- LS-W241**
PU Solid tire 200x75mm
- LS-W247**
PU Solid tire 200x50mm
- LS-W240**
PU Solid tire 200x50mm
- LS-W237**
PU Solid tire 200x50mm
- LS-W221**
PU Solid tire 200x50mm
- LS-W201**
LS-W201 PU Solid tire w/Plastic hub 200x50mm
- LS-W234**
PU Solid tire 190x27mm
- LS-W250**
PU Solid tire 7x1-3/4"
- LS-W246**
PU Solid tire 6x2"



PU Infilled Tyre, Puncture Free Tyre
Size: 7 x 1-3/4, 200 x 50, 260 x 85, 3.00-4, 4.00-5, 4.10/3.50-5, 3.00-8, 3.50-5 etc...

Elastomer Wheel



- LS-W216** (4") \$ 100x24 MM
- LS-W217** (5") \$ 127x27 MM
- LS-W218** (6") \$ 152x27 MM
- LS-W219** (6") \$ 152x36 MM



22"x1-3/8 24"x1-3/8 24"x1 24"x1
PU solid tyre

LEAD SINCE INDUSTRY CO., LTD.

立欣工業股份有限公司 彰化縣50544鹿港鎮彰濱工業區工業東三路15號
No. 15, Industrial E-3 Rd., Changbin Industrial Park, Lukang Town, Changhua Hsien 505, Taiwan.
Tel: 886-4-7810889, 7810329 Fax: 886-4-7810662, 7810434
E-mail: lead.since@msa.hinet.net lead.since@umail.hinet.net
http://www.leadsince.com.tw

Forks & Sub-Assembly

Excellent Smoothness in Omni-Directional Maneuverability

Nylon Forks Sub-Assembly Series

Available : 5" / 6" / 7" / 8" Nylon Rim

Aluminum Fork Sub-Assembly Series

Available : 3" / 4" / 5" / 6" Aluminum Rim



FK12 Series



FK458 Series



FK488 Series



PU Wheels Series

High Strength | Ultra Light Weight | Comfort | Performance | Precision | Durable Abrasion Resistance

Aluminum Rim / PU Tire Series

3" / 4" / 5" / 6" Width 1" & 1.4"



Nylon Rim / PU Tire Series

5" / 6" / 7" / 8" / 12"



8" - 200*50mm



Nylon Fork Series



Accessories

Foot Pedals
12" / 14" / 16" / 18"



Leg Rest (PVC Forming)



Anti-Tipping System



Adjustable

Arm Rest (PVC Forming)



Tube-Spacer



Rollator Screw



DISCOVER OUR WORLD OF CYCLING

Fotoquellen: 1-7 Markus Greber // 8 Daniel Simon



Europe's No.1 Bicycle Magazines.



Delius Klasing Publishing | P.O. Box 10 16 73 | 81369 Munich | Germany | www.delius-klasing.de
 Marion Hellmann | Phone: (+49) 89 729 60 237 | E-mail: m.hellmann@delius-klasing.de