



傳動系統

Transmission Parts

CHAINWHEELS AND CRANKS

Rivet Type

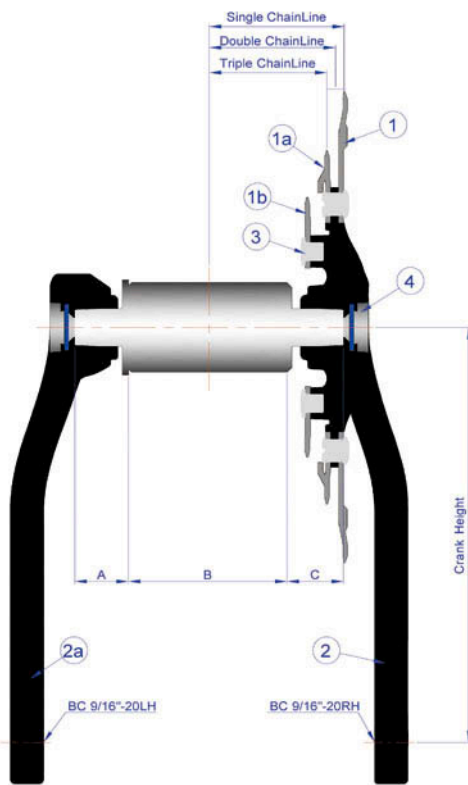

ITEM	COMPONENTS	ITEM	COMPONENTS
1		3	Rived
1a	Chainring	Outer	
1b		Middle	4 Pvc Cap
2	Crank	Inner	
2a		RH	
		LH	

Bolt Type

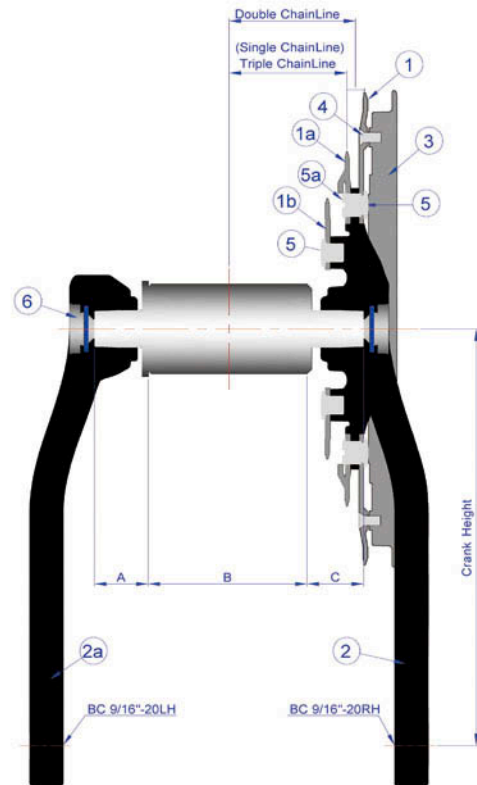

ITEM	COMPONENTS	ITEM	COMPONENTS
1		3	Chain cover
1a	Chainring	Outer	
1b		Middle	4 Screw
2	Crank	Inner	5 Fixing Bolt
2a		RH	5a Nuts
		LH	6 Axle Bolt

TRANSMISSION PARTS ADVERTISERS



D01 Chainwheels/Cranks

Andel Enterprise Co., Ltd. 瑞隆.....	544-547
First Bicycle Components Co., Ltd. 輪鋒.....	548
G-Ma Engineering Co., Ltd. 巨馬.....	549
Hsiang An Ent. Co., Ltd. 祥安.....	550-551
I Ling Ent. Co., Ltd. 毅麟.....	562
Jien Yuan Industry Co., Ltd. 健源.....	552-555
Jye Sen Ent. Co., Ltd. 傑森.....	556-557
Lunge Industry Co., Ltd. 輪俚.....	558-561
Neco Technology Industry Co., Ltd. 誌慶.....	563
Samox Components Co., Ltd. SAMOX.....	564-569
Shun Shing Bicycle Co., Ltd. 舜興.....	570-575
Sr Suntour Inc. 榮輪.....	576
Toptrans Company Ltd. 捷翰.....	577
Ufor Enterprise Co., Ltd. 侑鋒.....	578-579
Whole Man Enterprise Co., Ltd. 浩盟.....	580-583



Brand Companies

Peakbuyer Co., Ltd. 日澄.....	584
-----------------------------	-----



D02 Chains

Drivetrain Tech Solution Inc 傳誠.....	586-587
Kmc Chain Ind. Co., Ltd. 桂盟.....	588-589
Lixing Chain Co., Ltd. 力興鏈條.....	594
Taya Chain Co., Ltd. 大亞鏈條.....	590-591
Yaban Chain Industrial Co., Ltd. 雅邦.....	592-593



D03 Freewheels/Sprockets

Dnp (Long Yih Industry Co., Ltd.) 龍億工業.....	595
James White Co., Ltd. 品昂.....	596
Lida Machinery Co., Ltd. 利達機械.....	597
Seqlite Corp. 協佑.....	598



D04 Derailleur Gear Units

Falconcycle Tech Co., Ltd. 川飛.....	599
G.Falcon Cycle -Parts Co., Ltd. 大川飛.....	600
Sun Race Sturmey-Archer Inc. 日馳.....	1178

**Cycling is Good for
Your Health and the Environment !**



ANDEL®



NO.286-9, Sec.3 JHONGTOU W.RD.,
DALI DIST., TAICHUNG CITY 412 TAIWAN

TEL : 886-4-24063569, 24067825

FAX : 886-4-24077352

Email : andy@andel.com.tw

andylo88@seed.net.tw

瑞隆展業有限公司



RFB31-272F

Alloy crankset for MTB, Fat-bikes,

BCD 104/64.

Length: 160~220mm.

Teeth number : 33/21T, 34/22T,

36/22T, 39/25T, 34/24T,

36/26T, 38/28T, and others.

Color: silver or black.

Spindle 24mm or 30mm.

Integrated BB-set includes.



RS3M-176R

Crankset for -

Fixed gear / Track / Single-speed.

Alloy forged crank 3-arms.

Length: 160~175mm.

Alloy CNC chainring,

Teeth number:30T to 54T.

Finish:high-polish silver.

(Available in other colors)

Compatible BB-axle: square taper.



RNC21-217XR

(Extra length Crankset)

Crank arm: alloy forged.

BCD: 110mm. or 130mm,

Length: 180~220mm.

Alloy 7075-CNC Double Chainring

Color: silver or black,

(Available in other colors).

Integrated BB-set includes.

RNC21-317XR

(Extra length Crankset)

Crank arm: alloy forged.

BCD: 110/74mm. or 130/74mm,

Length: 180~220mm.

Alloy 7075-CNC Triple Chainring

Color: silver or black,

(Available in other colors).

Integrated BB-set includes.

RSC7-7172

Fixed gear / Track /Single-speed.

Alloy forged and CNC Crank arm.

BCD: 110, 130, 144mm.

Length: 160~175mm.

Alloy 7075-CNC Chainring,

Teeth size: 1/2"1/8" or 3/32"

Teeth number: 34T to 54T

Color: polished silver or black

(Available in other colors)

Compatible BB-axle: Square taper.

Chainring guard available.



RSC7-115

Crankset for -

Fixed gear / Track /Single-speed.

Alloy forged and CNC Crank arm.

BCD: 110, 130, 144mm.

Length: 160~175mm.

Cr-Mo steel Chainring

Teeth size: 1/2"1/8" or 3/32"

Teeth number: 34T to 54T

Color: polish silver or black.

(Available in other colors)

Compatible BB-axle: Square taper.



TRS2-7112 / 7122

Fixed gear / Track / Single-speed.

Alloy forged Crank arm

BCD: 144mm.

Length: 150~175mm.

Alloy 7075-CNC Chainring

Teeth size: 1/2"1/8" or 3/32"

Teeth number: from 42T to 54T.

Color: polished silver or black,

(Available in other colors).

BB-axle: square or ISIS.



RSC1-7102

Fixed gear / Track /Single-speed.

Alloy forged Crank arm

BCD: 144 or 130mm.

Length: 160~175mm.

Alloy 7075-CNC Chainring,

Teeth size: 1/2"1/8" or 3/32"

Teeth number: from 42T to 54T.

Color: polished silver or black,

(Available in other colors).

BB-axle: square or ISIS.



RSC1-510PB

Fixed gear / Track /Single-speed.

Alloy forged Crank arm.

BCD: 144 or 130mm.

Length: 160~175mm.

Alloy 6061 Chainring,

Teeth size: 1/2"1/8" or 3/32"

Teeth number: from 42T to 54T.

Color: polished silver or black,

(Available in other colors).

BB-axle: square or ISIS splined.



RSC1-5121

Fixed gear / Track /Single-speed.

Alloy forged Crank arm.

BCD: 144 or 130mm.

Length: 160~175mm.

Alloy 6061 Chainring,

Teeth size: 1/2"1/8" or 3/32"

Teeth number: from 42T to 54T.

Color: polished silver or black,

(Available in other colors).

BB-axle: square or ISIS splined.





RSC1-1171AW

(Single chainring with -
one-piece chain guard)

Alloy forged Crank arm

BCD: 144 or 130mm.

Length: 160~175mm.

Alloy CNC single-chainring,

Teeth number: from 39T to 100T.

Color: silver or black,

(Available in other colors).

BB-axle: square or ISIS splined.



RSC6-116AAW

(Single chainring with -
double chain guard)

Alloy forged Crank arm

BCD: 110mm.

Length: 145~175mm.

Alloy CNC Chainring,

Teeth number: from 34T to 60T.

Color: silver or black,

(Available in other colors).

BB-axle: square or ISIS splined.



RSC1-116AAW

(Single chainring with -
double chain guard)

Crank arm: alloy forged.

BCD: 144 or 130mm.

Length: 160~175mm.

Alloy CNC Chainring,

Teeth number: from 39T to 100T.

Color: silver or black,

(Available in other colors).

BB-axle: square or ISIS splined.



FW-710S(Steel)

FW-710A(Aluminum alloy)

(CNC Fixed Cogs)

Material: Cr-Mo steel,

Full CNC machined, and heat treatment.

Teeth size: 1/2-1/8" or 3/32"

Teeth number : 12T ~ 36T.

Thread size: BC1.37-24tpi.

Color: silver or black,

(Available in other colors).



FW-720S(Steel)

FW-720S(Aluminum alloy)

(CNC Single-Speed Cogs)

Material: Cr-Mo steel,

Full CNC machined, and heat treatment.

Teeth size: 1/2-1/8" or 3/32"

Teeth number : 12T ~ 36T.

With splined hole compatible free hub.

Color: silver or black,

(Available in other colors).



FW-810S

(Stainless Steel CNC Fixed Cogs)

Material: Stainless steel,

Full CNC machined.

Teeth size: 1/2-1/8" or 3/32"

Teeth number : 12T ~ 36T.

Thread size: BC1.37-24tpi.

Color: Metal shiny or Shiny black.

LK-710S

(Steel Lock-ring)

Full CNC machined, and heat treatment.

Color: silver or black,

(Available in other colors).

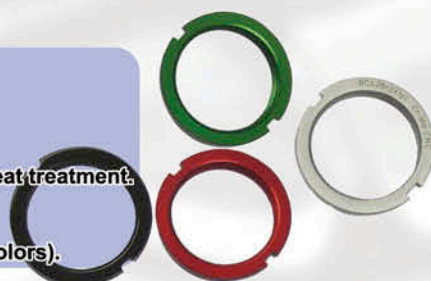

LK-810S

(Stainless Steel Lock-ring)

Full CNC machined.

Color: silver or black.



RSC61-317XR

Alloy forged Crank arm.
 BCD: 110/74mm.
 Length: 150~175mm.
 Alloy 7075-CNC Chainring:
 Teeth number : Outer 44~52T
 Middle 34~38T
 Inner 24~28T
 Color: silver or black,
 (Available in other colors).
 Integrated BB-set includes.



RSC2-217XR

Alloy forged Crank arm.
 BCD: 110mm.
 Length: 165~175mm.
 Alloy 7075-CNC Chainring:
 Teeth number : Outer 44~52T
 Inner 34~38T
 Color: silver or black,
 (Available in other colors).
 BB-axle: square or ISIS splined.



RS3M-276R

3-arms classical style crankset.
 Alloy forged and CNC machined Crank arm.
 Length: 160~175mm.
 Alloy CNC chainring
 Teeth number : Outer 42~52T
 Inner 30~38T
 Color: High-polish silver.
 BB-axle: Square taper.



RSC73-377PW

Alloy forged and CNC machined Crank arm.
 BCD: 94/58, 110/74, 130/74mm.
 Length: 160~175mm.
 Alloy 7075-CNC Chainring
 Teeth number : Outer 44~56T
 Middle 29~44T
 Inner 22~32T
 Color: silver or black,
 (Available in other colors).
 BB-axle: square taper.



RSC7-2371PW

Alloy forged and CNC machined Crank arm.
 BCD: 94 / 110 / 130mm.
 Length: 160~175mm.
 Alloy 7075-CNC Chainring
 Teeth number : Outer 44~54T
 Inner 30~42T
 Color: silver or black,
 (Available in other colors).
 BB-axle: square taper.



TMS11-374F

(Triple chainrings) 4-arms
 Alloy forged Crank arm.
 BCD: 104/64mm.
 Length: 155~175mm.
 Alloy 7075-CNC Chainring:
 Teeth number : Outer 42~48T
 Middle 32~36T
 Inner 22~26T,
 Color: silver or black,
 (Available in other colors).
 Integrated BB-set includes.



TMS21-372F

(Triple chainrings) 5-arms
 Alloy forged Crank arm.
 BCD: 94/58mm.
 Length: 155~175mm.
 Alloy 7075-CNC Chainring:
 Teeth number : Outer 41~44T
 Middle 28~30T
 Inner 20~22T,
 Color: silver or black,
 (Available in other colors).
 Integrated BB-set includes.



TMS1-107

(single chainrings) 4-arms
 Alloy forged Crank arm.
 BCD: 104mm.
 Length: 155~175mm.
 Alloy 7075-CNC Chainring
 Teeth number : 32T to 48T.
 Color: silver or black,
 (Available in other colors).
 BB-axle: square, ISIS-splined.



Upgraded Compact Crankset for Gravel Bike

GTM 100% CNC Production

- Crank Length: 165/170/172.5/175mm (AL6066-T6) • BCD: 110mm
- Chainring: 48x32^T, 46x36^T, 46x30^T (AL7075-T73)



Road/MTB/Single-Speed Cranksets



(4-Arm)

KT 100% CNC Production

- Crank Length: 165/170/172.5/175mm (AL6066-T6)
- BCD: 110mm
- Chainring: 53x39^T, 50x34^T, 52x36^T, 52x38^T (AL7075-T73)



(Semi-Oval Chainring)

OS/OS1 100% CNC Production

- Crank Length: 165/170/172.5/175mm (AL7050-T73)
- BCD: 130mm/110mm
- Chainring: 53x39^T/50x34^T (AL7075-T73)



(Oval Chainring)

OR/OC 100% CNC Production

- Crank Length: 165/170/172.5/175mm (AL7050-T73)
- BCD: 130mm/110mm
- Oval Chainring: 53x40^T/50x35^T (AL7075-T73)



CTm/RTm 100% CNC Production

- Crank Length: 165/170/172.5/175mm (AL7050-T73)
- BCD: 110mm/130mm
- Chainring: 50x34^T/53x39^T, 55x42^T (AL7075-T73)

RT1: Single-Chaining



DT2 (for Track)



- Crank Length: 165/170/172.5/175mm (AL6061-T6)
- BCD: 144mm
- Chainring: 47^T, 48^T, 49^T, 50^T, 51^T, 52^T (AL7075-T73)



MP (Fits Fat Bike)

- Crank Length: 165/170/172.5/175mm (AL6066-T6)
- BCD: 104/64mm
- Chainring: 36x22^T, 38x24^T (AL7075-T73)
- Axle Length: 177.5 or 190.5mm
- Fits BB Shell: 100 or 120mm
- MD:** Single-Chaining



MS 100% CNC Production

- Crank Length: 165/170/172.5/175mm (AL6066-T6)
- BCD: 104/64mm
- Chainring: 44x32x22^T (AL7075-T73)
- MH:** Double-Chaining
- MH1:** Single-Chaining



MR (Fits Fat Bike)



- Crank Length: 165/170/172.5/175mm (AL6061-T6)
- BCD: 104/64mm
- Chainring: 36x22^T
- For BB Shell Width 100mm
- MO:** Single-Chaining

Road/MTB Chainrings



R-M8000
(BCD: 96mm)



R-DEOR
(BCD: 96mm Symmetry)



R-DIMO3
R-DIMO6
(Offset: 3/6mm)



R-DIMO/RO-DIMO (Oval)



R-MXX
R-MXX2



R-CAMP (Campy)



R-NWO (Oval/Narrow-Wide)
R-MH1/R-CT1
(BCD: 104mm)/(BCD: 110mm)

MTB crankset 1x11s



XEN-A1



XONE-A1 Light



XONE-A1



X11-7N-A1

MTB crankset 2x10/3x10



X10-BX-A2D



X12-SL-A2D



X12-SL-A3



X11-7N-DH

DH cranks/ arm

BSA type



BB-05-XC-73/68



BSA30



BB-05-GXP



BB30 kit

Pressfit



PF2405/08



PF30AL05/08

Pressfit 30 adapter



PF30C24PL



PF30C24PLXC/RD

G-MA ENGINEERING Co.,Ltd.

www.aerozinebike.com

service@aerozinebike.com



祥安

HSIANG AN ENT CO., LTD.

No. 167 Sec. 2 Chang Shuei Rd. Puyen Tsun,
Puyen Hsiang, Changhua Hsien Taiwan.
Tel: 886-4-8659280~2
Fax: 886-4-8659284
E-mail: hsiangan@ms61.hinet.net



Model HA-550CC

Alloy Forged Crank & Alloy Spider 5
Arm & Alloy Chain Wheel
Teeth: 42T, 43T, 44T, 45T, 46T, 47T, 48T, 49T, 50T,
51T, 52T, 53T (#6061)(AL)
Chain Guard: (#6061)(AL) CNC
Bcd: 144
Crank Length: 155, 160, 165, 170, 175mm (#6061)(AL)
Chain Line: 45mm
B.B.Axle: JIS, ISIS



Model HA-550CG

Alloy Forged Crank & Alloy Spider 5
Arm & Alloy Chain Wheel & Alloy Chain Guard
Teeth: 42T, 43T, 44T, 45T, 46T, 47T, 48T, 49T, 50T,
51T, 52T, 53T (#6061)(AL)
Chain Guard: (#6061)(AL) 3mm CNC
Bcd: 144
Crank Length: 155, 160, 165, 170, 175mm (#6061)(AL)
Chain Line: 45mm
B.B.Axle: JIS, ISIS



Model HA-551CC

Alloy Forged Crank & Alloy Spider 5
Arm & Alloy Chain Wheel
Teeth: 42T, 43T, 44T, 45T, 46T, 47T, 48T, 49T, 50T,
51T, 52T, 53T (#6061)(AL) CNC
Bcd: 144
Crank Length: 155, 160, 165, 170, 175mm (#6061)(AL)
Chain Line: 45mm
B.B.Axle: JIS, ISIS



Model HA-551CG

Alloy Forged Crank & Alloy Spider 5
Arm & Alloy Chain Wheel & Alloy Chain Guard
Teeth: 42T, 43T, 44T, 45T, 46T, 47T, 48T, 49T, 50T,
51T, 52T, 53T (#6061)(AL)
Chain Guard: (#6061)(AL) 3mm CNC
Bcd: 144
Crank Length: 155, 160, 165, 170, 175mm (#6061)(AL)
Chain Line: 45mm
B.B.Axle: JIS, ISIS



Model HA-540CC

Alloy Forged Crank & Alloy Spider 5
Arm & Alloy Chain Wheel
Teeth: 39T, 40T, 41T, 42T, 43T, 44T, 45T, 46T,
47T, 48T, 49T, 50T, 51T, 52T, 53T, 56T
(#6061)(AL)CNC
Bcd: 130
Crank Length: 170, 175mm (#6061)(AL)
Chain Line: 45mm
B.B.Axle: JIS, ISIS



Model HA-540CG

Alloy Forged Crank & Alloy Spider 5
Arm & Alloy Chain Wheel & Alloy Chain Guard
Teeth: 39T, 40T, 41T, 42T, 43T, 44T, 45T, 46T, 47T, 48T,
49T, 50T, 51T, 52T, 53T, 56T (#6061)(AL)
Chain Guard: (#6061)(AL) 3mm CNC
Bcd: 130
Crank Length: 170, 175mm (#6061)(AL)
Chain Line: 45mm
B.B.Axle: JIS, ISIS



Model HA-540CD

Alloy Forged Crank & Alloy Spider 5
Arm & Alloy Chain Wheel
Teeth: 39T, 40T, 41T, 42T, 43T, 44T, 45T, 46T, 47T, 48T,
49T, 50T (#6061)(AL) CNC
Bcd: 130
Crank Length: 170, 175mm (#6061)(AL)
Chain Line: 45mm
B.B.Axle: JIS, ISIS

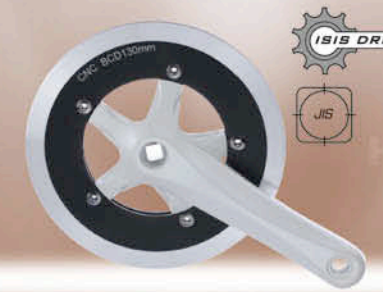

Model HA-540GCD

Alloy Forged Crank & Alloy Spider 5
Arm & Alloy Chain Wheel & Alloy Chain Guard
Teeth: 39T, 40T, 41T, 42T, 43T, 44T, 45T, 46T, 47T, 48T,
49T, 50T (#6061)(AL)
Chain Guard: (#6061)(AL) 3mm CNC
BCD: 130
Crank Length: 170, 175mm (#6061)(AL)
Chain Line: 45mm
B.B.Axle: JIS, ISIS



Model HA-505CD

Alloy Forged Crank & Alloy Spider 5 Arm & Alloy Chain
Wheel
Teeth: 40T, 41T, 42T, 43T, 44T, 45T, 46T, 47T, 48T, 49T,
50T (#6061)(AL) 3mm CNC
Bcd: 130
Crank Length: 155, 160, 165, 170, 175mm (#6061)(AL)
Chain Line: 44mm
B.B.Axle: JIS, ISIS





Model HA-406CD

Alloy Forged Crank & Alloy Spider 5 Arm CNC & Alloy Chain Wheel
 Teeth: 40T, 41T, 42T, 43T, 44T, 45T, 46T, 47T, 48T, 49T, 50T (#6061)(AL) 3mm CNC
 Bcd: 130
 Crank Length: 155, 160, 165, 170, 175mm (#6061)(AL)
 B.B.Axle: JIS



Model HA-406CC

Alloy Forged Crank & Alloy Spider 5 Arm CNC & Alloy Chain Wheel
 Teeth: 40T, 41T, 42T, 43T, 44T, 45T, 46T, 47T, 48T, 49T, 50T, 51T, 52T, 53T (#6061)(AL) 3mm CNC
 Bcd: 130
 Crank Length: 160, 165, 170, 175mm (#6061)(AL)
 B.B.Axle: JIS



Model HA-404C

Alloy Forged Crank & Alloy Spider 4 Arm & Alloy Chain Wheel & Steel Chain Wheel
 Teeth: 22T, 24T, (AL), 22T, 24T (ST)
 Bcd: 64
 Crank Length: 89, 102, 114, 127mm (#6061)(AL)
 B.B.Axle: JIS, ISIS



Model HA-326CC

Alloy Forged Crank & Alloy Spider 5 Arm & Alloy Chain Wheel
 Teeth: 40T, 41T, 42T, 43T, 44T, 45T, 46T, 47T, 48T, 49T, 50T, 51T, 52T, 53T, 56T (#6061)(AL)
 Bcd: 130
 Crank Length: 165, 170mm (#6061)(AL)
 Chain Line: 45mm
 B.B.Axle: JIS

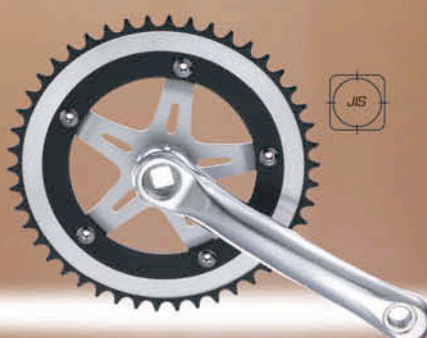

Model HA-326CD

Alloy Forged Crank & Alloy Spider 5 Arm & Alloy Chain Wheel
 Teeth: 40T, 41T, 42T, 43T, 44T, 45T, 46T, 47T, 48T, 49T, 50T (#6061)(AL) CNC
 Bcd: 130
 Crank Length: 165, 170mm (#6061)(AL)
 Chain Line: 45mm
 B.B.Axle: JIS



Model HA-65

1-PC Alloy Chain Wheel
 Teeth: 23T, 25T, 28T (#6061)(AL) 5mm CNC



Model HA-66

1-PC Alloy Chain Wheel & Steel Chain Wheel & Cr-mo Chain Wheel
 Teeth: 25T, 28T, 30T, 32T (#6061 AL 5m/m)(0.1kg)
 25T, 28T, 30T, 32T (#ST 2.6m/m)(0.1kg)
 25T, 28T, 30T, 32T (#Cr-mo 2.6m/m)(0.1kg)



Model HA-64

1-PC Alloy Chain Wheel
 Teeth: 23T, 25T, 28T (#6061)(AL) 5mm CNC



Model HA-C144CC

Alloy Chain Wheel
 Teeth: 42T, 43T, 44T, 45T, 46T, 47T, 48T, 49T, 50T, 51T, 52T, 53T (#6061)(AL) CNC
 Bcd: 144



Model HA-G144CC

Alloy Chain Guard
 Teeth: 42T, 43T, 44T, 45T, 46T, 47T, 48T, 49T, 50T, 51T, 52T, 53T (#6061)(AL) 3mm CNC
 Bcd: 144



Model HA-C130CD

Alloy Chain Wheel
 Teeth: 39T, 40T, 41T, 42T, 43T, 44T, 45T, 46T, 47T, 48T, 49T, 50T (#6061)(AL) CNC
 Bcd: 130



Model HA-G130CD

Alloy Chain Guard
 Teeth: 39T, 40T, 41T, 42T, 43T, 44T, 45T, 46T, 47T, 48T, 49T, 50T (#6061)(AL) CNC
 BCD: 130



A3470

AL6066 3D hollow forged Crank arms with Pedal Insert,
 Crank length:170,175,180mm,
 24.0mm Cr-mo Hollow Spindle ,M18 Alloy Spindle bolt .
 Alloy 4arms Spider & BCD:104mm
 AL6061 5.0mm CNC Chainring
 Teeth:40/41/42/43/44T
 BB Cups : BC 1.37**24/68mm



A3475

Monocoque Crankarms/Spider ,AL6061 forged Crank arms with Pedal Insert ,
 Crank length:170,175,180mm,
 24.0mm Cr-mo Hollow Spindle ,M18 Alloy Spindle bolt .
 AL6061 4arms Spider & BCD:104mm
 AL6061 5.0mm CNC Chainring
 Teeth:40/41/42/43/44T
 BB Cups : BC 1.37**24/68mm



A3473

Monocoque Crankarms/Spider ,AL6061 forged Crank arms with Pedal Insert ,
 Crank length:160,165,170,175,180mm,
 24.0mm Cr-mo Hollow Spindle ,M18 Alloy Spindle bolt .
 Alloy 4arms Spider & BCD:104mm
 AL6061 3.0mm Stamped Chainring
 Teeth:40/41/42/43/44T
 BB Cups : BC 1.37**24/68mm



A22

3 PIECES ALLOY 7050 CRANK with Pedal Insert
 ϕ22*4T Hollow SPINDLE
 W/M14 SPINDLE BOLTS

NEW Lightweight



C24CWPL (ϕ24*48T Hollow SPINDLE) C22CWPL (ϕ22*48T BUTTED SPINDLE)

Square shape crank arm
 3 PIECES CR-MO CRANK
 W/Alloy M18 or 5/8" SPINDLE BOLTS



C22CW-2P (ϕ22*48T HOLLOW SPINDLE) C19CW-2P (ϕ19*48T HOLLOW SPINDLE)

Square shape crank arm
 2 PIECES CR-MO CRANK
 W/M15 or M12 SPINDLE BOLT



C22AW (ϕ22*48T Hollow SPINDLE) C19AW (ϕ19*48T BUTTED SPINDLE)

Round shape crank arm
 3 PIECES CR-MO CRANK
 W/M15 or M12 SPINDLE BOLTS



C19C (ϕ31.8 tube) C19E (ϕ28.6 tube)

Square shape crank arm
 3 PIECES CR-MO CRANK
 ϕ19*48T SPINDLE & 3/8" SPINDLE BOLTS



C19A (ϕ31.8 tube) C19G (ϕ28.6 tube)

Round shape crank arm
 3 PIECES CR-MO CRANK
 ϕ19*48T SPINDLE & 3/8" SPINDLE BOLTS



C80R-2P

Round shape crank arm
 2 PIECES CR-MO CRANK
 ϕ19*8T HOLLOW SPINDLE
 W/M8 SPINDLE BOLT

NEW TSC



CT84R (ϕ31.8 tube) CT81R (ϕ28.6 tube)

Square shape crank arm
 TSC 3 PIECES CR-MO CRANK
 TSC ϕ19*8T TAPERED SPINDLE INTERFACE
 W/M8 SPINDLE BOLTS

NEW TSC



CT83R (ϕ31.8 tube) CT80R (ϕ28.6 tube)

Round shape crank arm
 TSC 3 PIECES CR-MO CRANK
 TSC ϕ19*8T TAPERED SPINDLE INTERFACE
 W/M8 SPINDLE BOLTS

			
<p>C8A (φ31.8 tube) C8G (φ28.6 tube) Round shape crank arm 3 PIECES CR-MO CRANK FOR φ19*8T SPINDLE INTERFACE</p>	<p>C8C (φ31.8 tube) C8E (φ28.6 tube) Square shape crank arm 3 PIECES CR-MO CRANK FOR φ19*8T SPINDLE INTERFACE</p>	<p>C83 (φ31.8 tube) C80 (φ28.6 tube) Round shape crank arm 3 PIECES CR-MO CRANK FOR φ19*8T SPINDLE INTERFACE</p>	<p>C84 (φ31.8 tube) C81 (φ28.6 tube) Square shape crank arm 3 PIECES CR-MO CRANK FOR φ19*8T SPINDLE INTER FACE</p>
	<p>NEW TSC</p> 		
<p>C83E (φ31.8 tube) C80E (φ28.6 tube) Round shape crank arm with Pin 3 PIECES CR-MO CRANK FOR φ19*8T SPINDLEINTER FACE</p>	<p>BB-8T-MP (Mid BB set) BB-8T-SP (Spanish BB set) FOR φ19*8T TSC TAPERED SPINDLE</p>	<p>BB-8A-A (American BB Set) BB-8A-E (Euro BB Set) FOR φ19*8T SPINDLE</p>	<p>BB-8A-MP (Mid BB Set) BB-8A-SP (Spanish BB Set) FOR φ19*8T SPINDLE</p>
	<p>NEW</p> 	 <p>BK-74A</p>	
<p>BB-8E-A (American BB Set) FOR φ19*8T LOOSE BALL SPINDLE</p>	<p>BK-PF30 (For 30mm Axle) BK-PF24 (For 24mm Axle) PF30 & PF24 Bottom brackets Used on Dia:46mm BB shell bike frame Material: AL7075 Forged & Full CNC Sealed bearing (Gray or Black cover) Can be used on both Road & MTB crankset</p>	<p>BK-74A (Black Cover) BK-86A (Black Cover) EXTERNAL EURO BB KIT BK-74A FOR φ24mm SPINDLE PRESS FIT ,Comatible Frame 86.92;ψ41*86.5mm BK-86A FOR φ24mm SPINDLE</p>	<p>BK-71A (Green Cover) BK-72A (Red Cover) EXTERNAL EURO BB KIT BK-71A FOR φ19mm SPINDLE BK-72A FOR φ22mm SPINDLE</p>
			
<p>BK-21A (Green Cover) BK-22A (Red Cover) AMERICAN BB KIT BK-21A FOR φ19mm SPINDLE BK-22A FOR φ22mm SPINDLE</p>	<p>BK-31A (Green Cover) BK-32A (Red Cover) SPANISH BB KIT BK-31A FOR φ19mm SPINDLE BK-32A FOR φ22mm SPINDLE</p>	<p>BK-51A (Green Cover) BK-52A (Red Cover) EURO BB KIT BK-51A FOR φ19mm SPINDLE BK-52A FOR φ22mm SPINDLE</p>	<p>BK-61A (Green Cover) BK-62A (Red Cover) BK-64A (Black Cover) MID BB KIT BK-61A FOR φ19mm SPINDLE BK-62A FOR φ22mm SPINDLE BK-64A FOR φ24mm SPINDLE</p>



WF68 (Alloy 5.0mm)
WF68S (Steel 2.6mm)

MATERIAL:AL6061 & Steel
 THICKNESS:Alloy 5mm & Steel
 2.6mm*Stamped
 SIZE: 1/2**1/8"
 TEETH: 25T,28T



WF67 (Alloy 5.0mm)
WF67S (Steel 3.0mm)

MATERIAL:AL6061 & Steel
 THICKNESS:Alloy 5mm & Steel
 3.0mm*Stamped
 SIZE: 1/2**1/8"
 TEETH: 25T,28T



WF66 (Alloy 5.0mm)
WF66S (Steel 2.6mm)

MATERIAL:AL6061 & Steel
 THICKNESS:Alloy 5mm & Steel
 2.6mm*Stamped
 SIZE: 1/2**1/8"
 TEETH: 25 - 39T



WF65 (Alloy 5.0mm)
WF65S (Steel 2.6mm)

MATERIAL:AL6061 & Steel
 THICKNESS: 5mm &
 2.6mm*Stamped
 SIZE: 1/2**1/8"
 TEETH: 25T,28T



WF02

MATERIAL:AL6061
 THICKNESS:5.0mm
 SIZE: 1/2**1/8"
 TEETH: 25 ~ 36T



WF08

MATERIAL:AL6061
 THICKNESS:6.35mm
 SIZE: 1/2**1/8"
 TEETH: 25 ~ 36T



WF09

MATERIAL:AL6061
 THICKNESS:5mm
 SIZE: 1/2**1/8"
 TEETH: 25 ~ 36T



WF14

MATERIAL:AL6061
 THICKNESS:6.35mm
 SIZE: 1/2**1/8"
 TEETH: 25T ~ 36T



WF15

MATERIAL:AL6061
 THICKNESS: 6.35mm
 SIZE: 1/2**1/8"
 TEETH: 25T ~ 36T



WF16

MATERIAL:AL6061
 THICKNESS: 5.0mm
 SIZE: 1/2**1/8"
 TEETH: 25T ~ 36T



WB02

MATERIAL:AL6061
 THICKNESS: 12.0mm
 SIZE: 1/2**1/8"
 TEETH: 25T ~ 36T



WD03 (For 19.0mm Spindle)
WD032 (For 22.0mm Spindle)

Full CNC 48T SPLINE-DRIVE SPROCKET
 W/φ19 OR φ22*48T CR-MO ADAPTER
 MATERIAL : AL7075 6.0mm
 SIZE: 1/2**1/8"
 TEETH: 25 ~ 30T

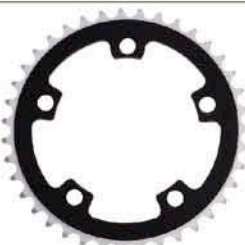

WS01

BCD: 110mm FOR 5 ARMS
 MATERIAL: ALLOY 6061
 THICKNESS: 3mm
 SIZE: 1/2**1/8", 1/2**3/32"
 TEETH: 34 ~ 48T



WS02

BCD: 110mm FOR 5 ARMS
 MATERIAL: AL6061
 THICKNESS: 3mm
 SIZE: 1/2**1/8", 1/2**3/32"
 TEETH: 34 ~ 48T



WS41

BCD: 104mm FOR 4 ARMS
 MATERIAL: AL6061
 THICKNESS: 3mm, 5mm
 SIZE: 1/2**1/8", 1/2**3/32"
 TEETH: 32 ~ 48T



SR5 (5 ARMS)
SR4 (4 ARMS)

SR5 BCD :110mm FOR 5 ARMS
SR4 BCD :104mm FOR 4 ARMS
 MATERIAL: AL6061
 THICKNESS: 5mm



HS-3

1 1/8" Integrated Headsets Bearing: sealed AC bearings
 φ41.8*45*8mm
 Material: AL6061 Top cover & Upper race
 Crown race : AL6061 or Steel Option
 Spacer : 2mm/3mm/5mm/10mm Option



CA-01/CA-01S / CA-05

MATERIAL: STEEL
CA-01 FOR φ19mm SPIINDLE
CA-01S FOR φ19mm SPIINDLE (STEEL SPROCKET)
CA-05 FOR φ22mm SPIINDLE



BA-01 / BT01

BA-01 Material is AL6061-T6 B.B CONVERTED ADAPTER FOR AMERICIAN B.B TO EURO B.B
BT01 STEEL CHAINRING BOLTS SPEC.: M8*0.75P



ASSEMBLY & REMOVAL TOOL

CT1 FOR φ19*48T*3/8" SPINDLE
CT1B FOR φ19*48T*M12 SPINDLE
CT2 FOR φ22*48T*M15 SPINDLE
CT2B FOR φ22*48T*5/8" SPINDLE
CT3 FOR φ24*48T*M18 SPINDLE
DT1N FOR φ19*48T*M12 SPINDLE



PA01 / PA02

PA01: MATERIAL IS ALLOY FORGED BODY+CR-MO SLEEVE
PA02: MATERIAL IS ENGINEERING PLASTICS BODY+CR-MO SLEEVE
 DIAMETER: φ38mm
 LENGTH: 110mm or 95mm



RT01

Upper Rotor plate for ST-613/614/617/618 Stem
 Material: Alloy
 Size: 1-1/8"



ST-608

AL6061 CNC FL STEM
 EXTENSION : 28 / 35 / 45mm
 STACK HEIGHT : 45mm
 BAR BORE: φ22.2mm



ST-620

AL6061 CNC FL STEM
 EXTENSION : 48mm
 STACK HEIGHT : 34mm
 BAR BORE: φ31.8mm



ST-617

AL6061 CNC TL STEM
 EXTENSION : 50mm
 STACK HEIGHT: 32mm
 BAR BORE: φ22.2mm



ST-618

AL6061 CNC FL STEM
 EXTENSION : 50mm
 STACK HEIGHT : 30mm
 BAR BORE: φ22.2mm



ST-613

AL6061 CNC TL STEM
 EXTENSION : 50mm
 STACK HEIGHT : 30mm
 BAR BORE: φ22.2mm



ST-614

AL6061 CNC FL STEM
 EXTENSION : 50mm
 STACK HEIGHT : 30mm
 BAR BORE: φ22.2mm



HB-H365

* Material: Cr-mo Butted & Heat-treatment

Model No.	Width mm(inch)	Rise mm(inch)	Bar bore
H365-10	762 (30")	254 (10")	φ22.2
H365-11	736 (29")	235 (9.25")	φ22.2
H365-12	710 (28")	222 (8.75")	φ22.2
H365-13	686 (27")	203 (8")	φ22.2



HB-H380

* Material: Cr-mo & Heat-treatment

Model No.	Width mm(inch)	Rise mm(inch)	Bar bore
H380-10	762 (30")	254 (10")	φ22.2
H380-11	736 (29")	228 (9")	φ22.2
H380-12	710 (28")	222 (8.75")	φ22.2



HB-A351

* Material: AL6061-T6

Model No.	Width mm(inch)	Rise mm(inch)	Bar bore
A351-10	660 (26")	165 (6.5")	φ22.2
A351-11	660 (26")	140 (5.5")	φ22.2
A351-12	610 (24")	115 (4.5")	φ22.2
A351-13	610 (24")	90 (3.5")	φ22.2



ZELE-A11



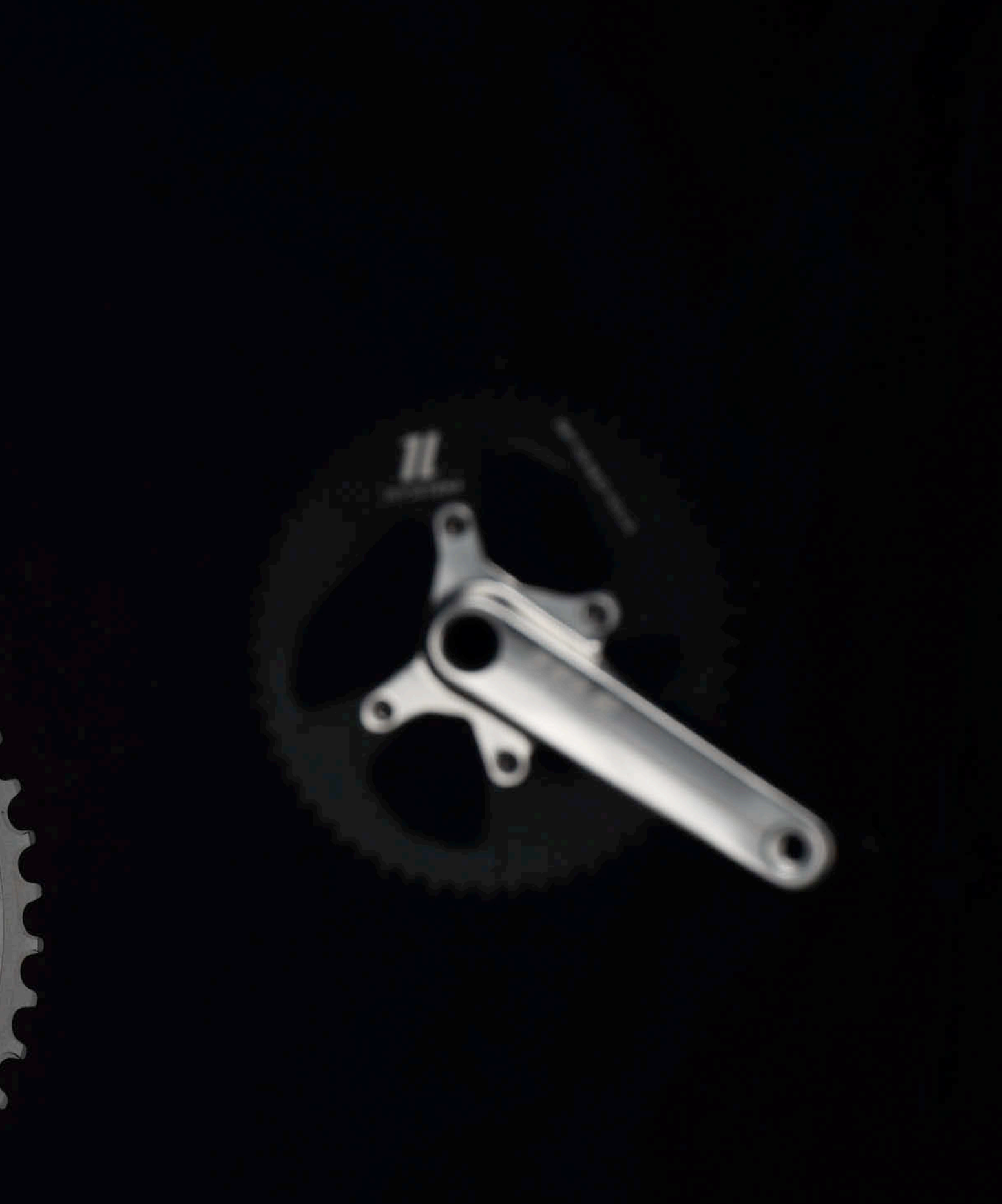

DRIVELINE 
www.driveline.com.tw



DIRT-101

x 32T, 34T, 36T, 38T, 40T, 42T
x Direct Mount Lasco system
x 175, 170, 165mm
x 6061 Forged AL Crank



DIRT-102

x 32T, 34T, 36T, 38T, 40T, 42T
x BCD 96
x 175, 170, 165mm
x 6061 Forged AL Crank



FM25-32X-GOX

x 32T
x 1x11, BCD104
x 170, 165, 160, 155, 145, 135, 125, 115mm
x 6061 Forged AL Crank



FM682-01-GOX

x 38T AL x 24T AL
x 10S, 9S, BCD104/96
x 175, 170, 165mm
x 6061 Forged AL Crank



FR65017GOX (10s)

x 50T AL CNC x 34T AL
x Integrated external bearing B.B system
x 6061 Forged AL crank
x 175, 170, 165mm / BCD 110mm



FR650A1 (ROAD)

x 50T AL CNC x 34T ST
x Interchangeable / ROAD COMPACT
x 6061 Forged AL crank
x 175, 170, 165mm / BCD 110mm



FR650-42X-GOX

x 42T Narrow & wide ring
x 1x11, BCD110(Compact)
x 175, 172.5, 170, 165mm
x 6061 Forged AL Crank



FM682-02-GOX

x 36T AL x 22T AL
x 10S, 9S, BCD104/64
x 175, 170, 165mm
x 6061 Forged AL Crank



SUV-200P (TREKKING)

48T AL CNC / 36T ST / 26T ST
Interchangeable w/ PVC cover
6061 alloy forged
175, 170, 165mm BCD 104 / 64mm



FR650-CLASSIC-2X (ROAD)

50T AL CNC / 34T AL
6061 Forged AL crank
175, 170mm / BCD 110mm



FG03-CLASSIC-AT13

48T, 46T AL ring, COVER available
6061 Forged AL crank / CNC POLISH
175, 170mm / BCD 130mm



VISTO-300P

46T AL CNC x 36T AL
GAL1 AL cover / laser
6061 Forged AL crank
175, 170, 165mm / BCD 110mm

**CRANK SET OPTIONS FOR E-BIKE MOTOR SYSTEM:
BOSCH/BROSE/PANASONIC/ YAMAHA/ FAZUA
BAFANG/SHENGYI/VINKA**

AVAILABLE IN: ISIS, SQUARE, BNI
6061 Alloy forged Crank
S.B BK anodized, Brush BK anodized
175 / 170 / 165 / 152mm



EB01



EB35



EB05



EB07



EB06

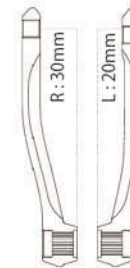

R: 30mm

L: 20mm

EB10



EB08

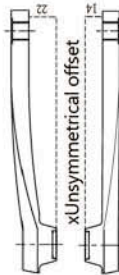

x/Asymmetrical offset



EB116

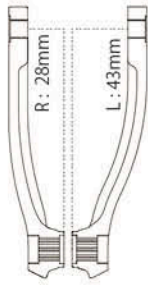

R: 28mm

L: 43mm

Offset measure element reference
彎度測量圖示



OFFSET

	Offset 彎度
EB01	28
EB05	22.5
EB06	28
EB07	27.5
EB10	L:20/R:30
EB611	L:28/R:43
EB116	L:43/R:28

-tone FINISHING / TITANIUM EB07



For Bosch Active line



x size: 38T, 42T, 44T

- EM11-38T-G
- EM11-42T-G
- EM11-44T-G
- EM11-46T-G
- EM11-48T-G



x size: 46T, 48T

- x 38T, 42T, 44T, 46T, 48T
- x Chainguard: D29A: Alloy BK/CNC
- x spider: EM11: Alloy BK
- x C.L: 47.5mm



EM16-42T-GA24/B

- x EM16 spider+ 1DT05
- x Chaining: 48T, 46T, 44T, 42T
- x Steel ED BK
- x BCD 104mm
- x GA24/B Alloy cover



EM20-48T-GA33

- x EM14 spider+ 1DT05
- x Chaining: 52T, 50T, 48T, 46T
- x Steel ED BK
- x BCD 130mm
- x GA24/B Alloy cover



EM20

- x Spider for Bosch/Gates
- x Alloy 6061 Forged
- x BCD130
- x Finish: S.B. Anod.
- x Beltline: 43.7mm/46mm

Economic version for BOSCH Active line



EM14-38T-1DT0-GA32

- x Chainguard: Alloy, BK/CNC
- x available size: 38T, 42T/44T
- x Chainguard: Alloy, BK/CNC
- x BCD104mm



EM14-2D09

- x DOUBLE RING
- x Ring: 44Tx32T
- x 6061-T6 Alloy Forged spider
- x BCD104/64mm



EM09-38T-GA8

- x Ring: 36T, 38T, 42T, 44T,
- x BCD 104mm



EB07-EBG20-38T

- x MaxDrive, Modest
- x Alloy Crank: 170mm
- x Alloy Cover: D: 110mm
- x Steel ring: S161-38T



E-BIKE/ SHENGYI



EM22-38T-GA8

- x Ring: 36T, 38T, 42T, 44T,
- x Chainline 52mm
- x BCD 104mm



EM19-48T-GA24B

- x Torque Sensor
- x Ring: 36T, 38T, 42T, 44T

E-BIKE/ FAZUA



PW

EM06-38T-GA8

- x Ring: 1D4S : Steel
- x Size: 38T, 40T, 42T, 44T
- x Chainguard: GA8 : Alloy



E-BIKE/ NIDEC

EM10-38/48T-PF01

- x Max Drive, Modest System
- x DOUBLE RING
- x Ring: 38Tx 48T



PW

EM30-2D09

- x DOUBLE RING
- x Ring: 44T x 32T
- x 6061-T6 Alloy Forged spider
- x BCD104/64mm



EM05-2D-07

- x DOUBLE RING
- x Ring: 42TAL x 28T ST
- x BCD104/64mm



EM10-48T-GA10/B

- x Max Drive, Modest System
- x Ring: 36T, 38T, 42T, 44T, 46T



PWX

EM29-P2DG-2D10-GA31

- x DOUBLE RING
- x Ring: 48Tx36T
- x Chainguard: D31 Alloy BK/CNC
- x 6061-T6 Alloy Forged spider



EM05-1DX3-38T

- x Ring: 38T AL Narrow & Wide
- x Regular ring: 36T, 38T, 42T, 44T



EM33A-38T-NW

- x M500, M520 SPORTIVE VERSION
- x BCD 104mm
- x Single ring 38T Steel Narrow Wide
- x Chainline: 52mm

E-BIKE/ YAMAHA

E-BIKE/ BROSE

E-BIKE/ BAFANG



FM26-32A

- x 32T Narrow & wide ring
- x BCD 104mm
- x 114-155mm
- x 6061 Forged AL Crank



FM26-32A-GA0

- x 32T AL ring
- x BCD 104mm, 114-155mm
- x 6061 Forged AL Crank
- x GA0 AL double cover



FM2630-DPFF06

- x 30T, 32T AL or ST ring
- x BCD 104mm, 114-155mm
- x 6061 Forged AL Crank
- x PF06 PVC double cover



RCF2630-DPFF06

- x 30T, 32T ST ring
- x 90mm-155mm
- x 6061 Forged AL Crank
- x PF06 PVC double cover



RCF2634_DPC01

- x 32T, 33T, 34T
- x 90mm-155mm
- x 6061 Forged AL Crank
- x PC01 PVC double cover



RCF2628_DPC10

- x 28T ST ring
- x 90mm-155mm
- x 6061 Forged AL Crank
- x PC10 PVC double cover

JUNIOR RANGE



EM21
BAFANG/TORQUE SENSOR



EM14
FAZUA



EM10A
BAFANG/ MAX DRIVE



EM09
SHENGYI/CMT03



EM08
BROSE/ FAT BIKE



EM17
VINKA/ UKL7-UK18



EM05
BROSE



EM29
YAMAHA/ PWX



EM16
BOSCH



EM22
NIDEC

SPIDER OPTIONS FOR MID DRIVE MOTORS

FR610 CRANK COMPATIBLE WITH GATES

Gates Beltline reference	B.B Axle Length	Actual Beltline for FR610 w/ GATES	
		Tolerance: ±1.0mm	
39.8mm	111mm	39.2mm	
43.8mm	118mm	43.7mm	
43.7mm		43.7mm	
43.3mm		43.7mm	
43mm	119mm	44.7mm	
44.6mm		44.7mm	
44.8mm	115mm	42.2mm	
42.1mm		42.2mm	
41.5mm		41.7mm	



FR610-80T-BELT

- x C-DRIVE AL belt drive sprocket
- x 66T, 72T, 80T
- x 12mm/ H8M, PU belt
- x 6061 AL forged crank
- x BCD 130mm
- x CUSTOM SPROCKET SIZE AVAILABLE

BELT DRIVE SYSTEM

輪傳
萊斯克





I L I N G ENTERPRISE CO., LTD.
 TEL: +886-4-777 2128
 FAX: +886-4-776 4896
 E-MAIL: iling@oro.com.tw
www.oro.com.tw



▶▶▶ **FREEWHEEL**



CSF03
 sprocket freewheel
 cnc machined
 al7075-t6
 size: 50t
 compatible shimano
 w/o spacer

CSF01
 sprocket freewheel
 cnc machined
 al7075-t6
 size: 40t/42t
 compatible sram/shimano
 w/o spacer



▶▶▶ **SINGLE CHAINWHEEL**



CSF02
 sprocket freewheel
 cnc machined
 al7075-t6
 size: 40t/42t
 compatible sram/shimano
 w/o spacer

SCR-01 (ROUND)
 10/11speed
 single chainwheel
 size: 30t/32t/34t/36t/38t
 al7075-t6
 heat treatment
 104 mm bcd

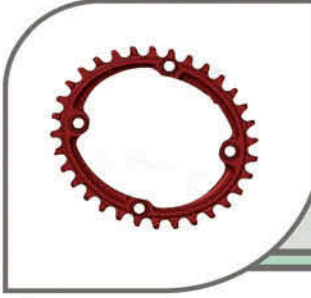
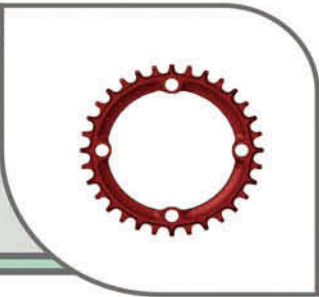

SCO-01 (OVAL)
 10/11 speed
 single chainwheel
 size: 30t/32t/34t/36t/38t
 al7075-t6
 heat treatment
 104 mm bcd

SCR-02 (ROUND)
 10/11speed
 single chainwheel
 size: 28t/30t/32t/34t/36t/38t
 al7075-t6
 heat treatment
 96 mm bcd

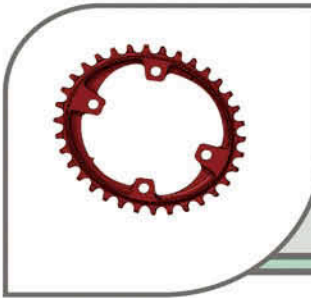
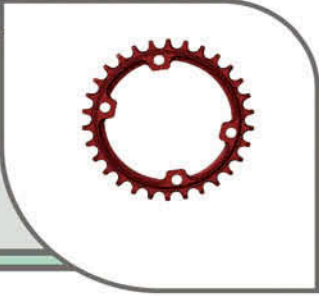

SCO-02 (OVAL)
 10/11 speed
 single chainwheel
 size: 30t/32t/34t/36t/38t
 al7075-t6
 heat treatment
 96 mm bcd

DMR6 (ROUND)
 direct mount chainring
 sram x-sync
 6 mm offset
 al7075-t6
 size: 28t/30t/32t/34t/36t/38t

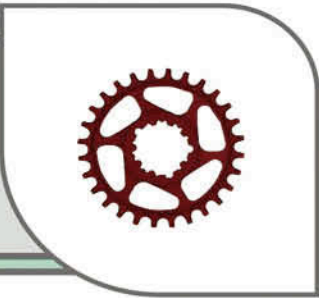

▶▶▶ **PULLEY**

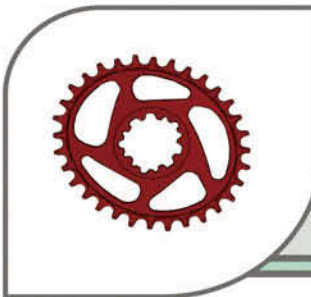

DMO6 (OVAL)
 direct mount chainring
 sram x-sync
 6 mm offset
 al7075-t6
 size: 30t/32t/34t/36t/38t

PL-7075-01
 cnc machined
 al7075
 size: 11t/12t/13t/14t/15t/16t

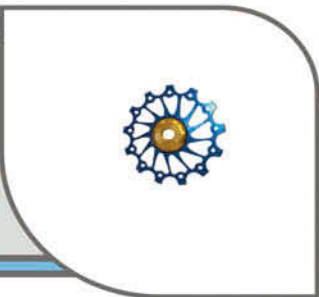



neco

Professional Bike
Parts Manufacturers

NECO TECHNOLOGY INDUSTRY CO., LTD

www.necoparts.com



NSS-3001

CRANK	Steel
LENGTH	170mm
SPROCKET	Steel
SIZE	24/34/42T or 28/38/48T



NSS-3002

CRANK	Steel
LENGTH	170mm
SPROCKET	Steel
SIZE	24/34/42T



NSS-1005

CRANK	Steel
LENGTH	89mm/102mm/ 127mm/140mm
SPROCKET	Steel
SIZE	28T or 32T or 36T



NSA-3002

CRANK	Alloy
LENGTH	170mm
SPROCKET	Steel
SIZE	24/34/42T or 28/38/48T
FINISH	Silver, Black



NSP-3002

CRANK	Plastic-Coated Steel
LENGTH	152mm/170mm
SPROCKET	Steel
SIZE	24/34/42T or 28/38/48T



NSA-3007

CRANK	Alloy
LENGTH	170mm
SPROCKET	Steel
SIZE	22/32/44T



NSA-1004

CRANK	Alloy
LENGTH	170mm
CHAINRING	38T or 42T, Steel



NSP-3001

CRANK	Plastic-Coated Steel
LENGTH	102mm/127mm/140mm/ 152mm/170mm
CHAINRING	24/34/42T or 28/38/48T, Steel



MA9-531C-NT

CRANK	170mm (Forged AL6061-T6)
CHAINRING	24/32T(steel);42T(Alloy)
BB	Cups-BC-1.37x24/68mm/73mm
CHAIN LINE	50mm
BCD	104/64mm
SPEED	3x10S
WEIGHT	890g



MA9-431C

CRANK	170mm(Forged AL6061-T6)
CHAINRING	24/32/42T(steel)
BB	Taper Square 110.5mm/M8
CHAIN LINE	50mm
BCD	104/64mm
SPEED	3x10S



FA3-212MAA

CRANK	170,172.5,175mm (Forged AL6061-T6)
CHAINRING	52T(AL6061T6 CNC)
BB	Cups-BC-1.37x24/68mm/73mm
BCD	130mm
CHAIN LINE	43mm



SA18-312E-NT

CRANK	165,170,175mm
CHAINRING	46,48T(AL6061T6 CNC)
BB	Cups-BC-1.37x24/68mm/73mm
BCD	144mm
CHAIN LINE	43mm

| Taiwan: neco@necoparts.com • Tel: +886-4-23323966
| Shunde: sdneco@vip.126.com • Tel: +86-757-22626599

| Nanjing: Neco-zj@vip.163.com • Tel: +86-511-87455666/777/888
| Tianjin: tjneco@163.com • Tel: +86-22-59591629

E-Bike Front Transmission Parts

Design front transmission parts compatible with Brose/Bosch/Bafang/Yamaha/Shimano...etc.



Chainline Option

Provide Different E-Bike Spider sets have different chainline Option



CL:45/47/49/52/65/68/72/75

Crankarm Option

Crankarm offset and Interface Option:

Provide not just shape design, Different motor spindle interface option JIS/ISIS/BNI/SML(SML for Shimano), and crankarm offset option for different frame design (Offset 0mm,5mm,9mm,13mm and 30mm Option)



Crankarm: 6061 Alloy Forged Crankarm
 Length: 150/155/160/165/170/175mm

Single and Double E-Chainring List

Single Chainring Option: Specs: Standard Steel Ring or NW Steel Ring



Standard Steel Ring



Narrow Wide Ring

BCD	CW Standard Steel Teeth Ring	NWS Narrow-Wide Steel Ring
4-Arm 76mm	x	28~32
4-Arm 104mm	32~46	32~46
5Arm-130mm	40~52	40~52

Note: NW Series Chainring Just for even number Teeth

Double Chainring Option: Specs: Larger Alloy Ring/ Smaller Steel Ring

Bike Category	Teeth Combination	Model #	BCD	Chainline
MTB	36/22	23101CS	104/64	49 or 52
	36/26	23901CS		
	38/24	23001CS		
	38/28	24201CS		
	40/28	21701CS		
Trekking	44/32	24001CS	104	9s/10s
	42/28	24501CS	104/64	
	44/30	24601CS		
Road	48/36	24101CS	104	44
	46/34	21901CS	110	
	48/38	22701CS		
	50/34	22001CS		

Spindle Bolts and Chainring Bolts Option

JIS Spindle Bolt	ISIS Spindle Bolt	Chainring Bolt & Nut

• M8x0.75 (L 6.5/8.5/10.5/14/16mm)



• Chainring: 15~20T

NARROW WIDE TEETH



• Chainring: 14/16/18/20T



• Chainring: 16T (Narrow Wide Teeth with Chainguard (One Piece Design))
 Option: 16T, 18T, 20T



Chainguard Option

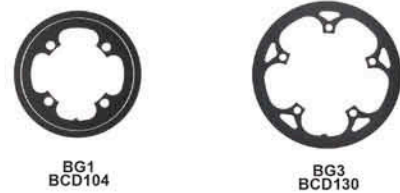

E-Bike front transmission with Belt Drive System

The E-Bike Spider design to compatible with Gates/Continental Belt-Drive system and rear internal hub system (Shimano, Nuvinci & Rohloff). The belt drive system belt line is very sensitive.

The crankset is designed to provide below table belt line to compatible with internal hub system.

Note:

1. Each motor series have compatible Spider to fit
2. Compatible with Shimano/Nuvinci/Rohloff Internal Hub system
3. Some internal hub system belt line is small. Need to adjust move motor center to Non-drive side.

BCD104mm Spider



BCD130mm Spider





MSC (Monocoque Structure Chainring)



- One Piece Chainring Design (3-in-1 or 2-in-1)
- AL 7075 8mm Outer Chainring Thickness
- Outer Chainring with Beam Reinforcing Rib Structure
- Direct Mount Interface
- 53/39T, 52/36T, 50/34T, 46/36T Option

23101C



23301C



22901C



Aone is our answer to the narrow wide tooth profile chainring. We redesigned the tooth profiles for better chain retention and reduced wear. Engineered for chains from 9spd all the way to 11spd. The Aone series is available in Alloy and Steel versions.

Aone (Narrow Wide System)



- Specs**
- BCD76 (4Bolt)
 - BCD104 (4Bolt)
 - BCD110 (5Bolt)
 - DM(Direct Mount)

DM (Direct-Mount Interface)

DMT

DMB



(Offset 6mm)



(Offset 3mm for Boost)

- Material & Process**
- NWC+ : 7075 Aolly CNC
 - NWC : Alloy CNC
 - NWA : Alloy Forged
 - NWS : Steel Forged

Narrow Wide Chainring BCD & Material Chart

Chainring Material	B.C.D / Riveted				
	4Arm-BCD76	4Arm-BCD104	5Arm-BCD110	5Arm-BCD130	Riveted
NWC (CNC Chainring)	26T~32T	30T~48T	38T~50T	X	X
NWA (Alloy Forged)	28T~32T	32T~48T	38T~50T	40T~52T	28T~44T
NWS (Steel Forged)	28T~32T	32T~48T	X	40T~52T	28T~44T

	DM				BCD76					BCD104				BCD110			
	DM	BCD76	BCD104	BCD110	DM	BCD76	BCD104	BCD110	DM	BCD76	BCD104	BCD110	DM	BCD76	BCD104	BCD110	
NC*					NA												
Chainring Model Number	DMT-05 26-40T	NWP504 26-32T	NWP213 32-36T	NWP106 38-42T	Chainring Model Number	DMT-01 26-36T	NWP502 28-32T	NWP201 32-34T	NWP203 36-40T	NWP103 38-44T							
NC					NS												
Chainring Model Number	DMT-06 26-40T	NWP501 26-32T	NWP206 32-36T	NWP203 38-42T	Chainring Model Number	DMT-01 26-36T	NWP503 28-32T	NWP201 32-34T	NWP202 42-48T								

MTB

M7 SERIES(CARBON)

BCM01-D30NC-05



M5 SERIES(HOLLOW FORGED)

THP11-D32NC



M3 SERIES(ALLOY FORGED)

TAP38-231AA



SPECIFICATIONS

Crankset	2Pcs DM Double&Single Chaining Crankset with 30mm Alloy Spindle
Crankarm	Hollow Carbon Crankarm Direct Mount & 4Arm BCD 104/64 Spider Option Length 165,170,175,180mm Option
Chaining Spec.	Double & Single(Standard or Narrow Wide) Chaining Teeth Option Material: Double /C:CNC,A/C: CNC with edge, A:Alloy,S:Steel Single NW /NC:CNC,NC/C:CNC with edge NA:Alloy forged,NS:Steel forged Option
Chainline	49mm
BB sets	BB3002, PF3002 or EB3001 Option

SPECIFICATIONS

Crankset	2Pcs DM Double&Single Chaining Crankset with 24mm Cr-Mo Spindle
Crankarm	Hollow Alloy Forged Crankarm Direct Mount & 4Arm BCD 104/64 Spider Option Length 170,175,180mm Option
Chaining Spec.	Double & Single(Standard or Narrow Wide) Chaining Teeth Option Material: Double /C:CNC,A/C: CNC with edge, A:Alloy,S:Steel Single NW /NC:CNC,NC/C:CNC with edge NA:Alloy forged,NS:Steel forged Option
Chainline	49mm
BB sets	EB2401(External BB) or BB9201(Press Fit BB)

SPECIFICATIONS

Crankset	2Pcs DM Double&Single Chaining Crankset with 24mm Cr-Mo Spindle
Crankarm	6061 Alloy Forged Crankarm Direct Mount & 4Arm BCD 104/64 Spider Option Length 170,175,180mm Option
Chaining Spec.	Double & Single(Standard or Narrow Wide) Chaining Teeth Option Material: Double /C:CNC,A/C: CNC with edge, A:Alloy,S:Steel Single NW /NC:CNC,NC/C:CNC with edge NA:Alloy forged,NS:Steel forged Option
Chainline	49mm
BB sets	EB2401(External BB) or BB9201(Press Fit BB)

TAF38-306AAA/C

TAF31-306AAA/C

TAF26-306AAA/C



SPECIFICATIONS

Crankset	3PCS Alloy Double Crankset
Crankarm	4Arm BCD104 6061 Alloy Forged Crankarm Length: 170,175mm Option
Chaining Spec.	36/22T Material: C:CNC, A/C: Alloy with CNC edge, A: Alloy, S:Steel Option
Chainline	49mm
BB sets	JIS or ISIS
Accessories	Chainguard Option

AM38-D28NS

AM33-D28NS

AF26-230AA

AF38-306AAA/C

★ AF29-321AA-P



ROAD

R7 SERIES(CARBON)

BCM05-20801C



R5 SERIES(HOLLOW FORGED)

THM10-D42NC-05



M3 SERIES(ALLOY FORGED)

TAP37-208CC



SPECIFICATIONS

Crankset	2Pcs DM Double&Single Chaining Crankset with 30mm Alloy Spindle
Crankarm	Hollow Carbon Crankarm Direct Mount & 5Arm BCD 130 Spider Option Length 170,172.5,175mm Option
Chaining Spec.	Double & Single(Standard or Narrow Wide) Chaining Teeth Option Material:Double /C:CNC,A/C: CNC with edge, A:Alloy,S:Steel Single NW /NC:CNC,NC/C:CNC with edge NA:Alloy forged,NS:Steel forged Option
Chainline	43.5mm
BB sets	BB3001, PF3001 or EB3001 Option

SPECIFICATIONS

Crankset	2Pcs DM Double&Single Chaining Crankset with 24mm Cr-Mo Spindle
Crankarm	Hollow Alloy Forged Crankarm Direct Mount & 5Arm BCD 130 Spider Option Length 170,172.5,175mm Option
Chaining Spec.	Double&Single(Standard or Narrow Wide) Chaining Teeth Option Material:Double /C:CNC,A/C: CNC with edge, A:Alloy,S:Steel Single NW /NC:CNC,NC/C:CNC with edge NA:Alloy forged,NS:Steel forged Option
Chainline	43.5mm
BB sets	EB2401(External BB)orBB9201(Press Fit BB) option

SPECIFICATIONS

Crankset	2Pcs DM Double&Single Chaining Crankset with 24mm Cr-Mo Spindle
Crankarm	6061 Alloy Forged Crankarm Direct Mount & 5Arm BCD 130 Spider Option Length 170,172.5,175mm Option
Chaining Spec.	Double&Single(Standard or Narrow Wide) Chaining Teeth Option Material:Double /C:CNC,A/C: CNC with edge, A:Alloy,S:Steel Single NW /NC:CNC,NC/C:CNC with edge NA:Alloy forged,NS:Steel forged Option
Chainline	43.5mm
BB sets	EB2401(External BB)orBB9201(Press Fit BB) option

GRAVEL/CYCLOCROSS

TAF13-D40NC



TAF37-D40NC



TAF37M-255CA



TBF37M-255CA



AF11-D42NC



AF19-225AA



TRACK

TAF19-1-U65C



SPECIFICATIONS

Crankset	2PCS Alloy Single Crankset with 24mm Cr-Mo Spindle
Crankarm	5Arm BCD144mm 6061 Alloy Forged Crankarm Length: 165, 170,175mm Option
Chaining Spec.	55 to 65T (Option as below table) Material: C:CNC, A/C: Alloy with CNC edge, A: Alloy, S:Steel option
Chainline	43.5mm
BB sets	EB2401(External BB) or BB9801(Press Fit BB)

232 : 48/32T
 255 : 46/30T
 256 : 44/28T

Taiwan Bicycle Source 2018-2019

JUNIOR/KIDS



TAF38J-231AA	TAF38J-D32A	AF16M-D32A-BG18	SAC03-111P1-1	SAC30-111P1-1
Crankset 2Pcs Alloy Double Crankset with 24mm Cr-Mo Spindle	Crankset 2Pcs Alloy Single Crankset with 24mm Cr-Mo Spindle	Crankset 3Pcs Alloy Single Crankset	Crankset 3Pcs Alloy Riveted Crankset	
Crankarm 4Arm BCD104/64mm 6061 Alloy Forged Crankarm Length: 140~170mm Option 36/22T	Crankarm 4Arm BCD104mm 6061 Alloy Forged Crankarm Length: 140~170mm Option 32~38T	Crankarm 4Arm BCD104mm / 6061 Alloy Forged Crankarm Length: 140~170mm Option 32~38T	Crankarm 6061 Alloy Forged Crankarm	
Chaining Spec. Material: A/C: Alloy with CNC edge, A: Alloy, S: Steel Option	Chaining Spec. Material: A/C: Alloy with CNC edge, A: Alloy, S: Steel Option	Chaining Spec. Material: A/C: Alloy with CNC edge, A: Alloy, S: Steel Option	Chaining Spec. 25/28/32/36T Material: A/C: Alloy with CNC edge, A: Alloy, S: Steel Option	
BB sets EB2401 or BB9201	BB sets EB2401 or BB8601	BB sets JIS	BB sets JIS	
Accessories Chainguard Option	Accessories Chainguard Option	Accessories Chainguard Option	Accessories Chainguard Option	

BMX RACING

JUNIOR RACING

BCP02-D44A	THP07-D44A-PI	BHP09-U44A-PI	TAF23-U36A-SL	AF23-U36A
<ul style="list-style-type: none"> • BCD104 4Arm Carbon Crank • 170/175/180mm • Alloy/44, 42, 40, 38, 36T • BB-BB3002(BB30)/BB-PF3002(PF30) 	<ul style="list-style-type: none"> Crankset: 2Pcs Alloy Crankset with 24mm Cr-Mo Spindle Crankarm: 6061 Hollow Alloy Forged Crankarm 4Arm BCD104mm Length: 170, 175, 180mm Option Chaining: 48/46/44/42/40/38T Option Material: A: Alloy S: Steel Option Chainline 43.5mm BBsets: EB24 : BB-EB2401 BB92 : BB-BB9201 	<ul style="list-style-type: none"> • BCD104 4Arm Alloy Forged Crank • 170/175/180mm • Alloy/44, 42, 40, 38, 36T • BB-BB3002(BB30)/BB-PF3002(PF30) 	<ul style="list-style-type: none"> Crankset: 2Pcs Alloy Crankset with 24mm Alloy Spindle Crankarm: 6061 Alloy Forged Crankarm 5Arm BCD110mm Length: 127~170mm Option Chaining: 44/42/40/38/36/34T Option Material: A: Alloy S: Steel Option Chainline 43.5mm BBsets: EB24 : BB-EB2401 BB92 : BB-BB9201 	<ul style="list-style-type: none"> • BCD110 5Arm Alloy Forged Crank • 135-170mm • Alloy/42, 41, 40, 39, 38, 36, 34T

FREESTYLE

BFC-P333S	BFC-33S	BFC-1818S	BFC-1212S
<ul style="list-style-type: none"> • 2.5P Cr-Mo 31.8mm Tubular Crank • Left Side Arm With 22mm-48T Spindle • 170/175mm 	<ul style="list-style-type: none"> • Three Piece Cr-Mo 31.8mm Tubular Crank • Left Side Arm With 22mm-48T Spindle • 170/175mm 	<ul style="list-style-type: none"> • Two Piece Cr-Mo 28.6mm Smaller Tubular Crank • Left Side Arm With 19mm-48T Spindle • 170/175mm 	<ul style="list-style-type: none"> • Two Piece Cr-Mo 31.8mm Tubular Crank • Left Side Arm With 19mm-48T Spindle • 170/175mm
BFC-1823S	BFC-225U	BFC-25V/U	BFC-25S/R
<ul style="list-style-type: none"> • Two Piece Cr-Mo 28.6mm Smaller Tubular Crank • Left Side Arm With 19mm-8T Spindle • 170/175mm 	<ul style="list-style-type: none"> • Two Piece (Press Fit) Cr-Mo 31.8mm Hexagonal Crank • Left Side Arm With 19mm-8T Spindle • 170/175mm • Painting color Only 	<ul style="list-style-type: none"> • Three Piece Cr-Mo Tubular Crank • 31.8mm Hexagonal, Square Shape Arm with V(Ridge) At Two Sides • 19mm-8T Spindle • 170/175mm 	<ul style="list-style-type: none"> • Three Piece Cr-Mo Tubular Crank • 31.8mm Square Shape Arm • 19mm-8T Spindle • 170/175mm
BFC-22H-2			
<ul style="list-style-type: none"> • ICS(Internal Clamping System) • Three Piece Cr-Mo Tubular Crank • 31.8mm Square Shape Arm • Enhance One Piece Forged Head • 19mm-8T Spindle • 170/175mm 			

3PCS Cr Mo(48T)	Sealed BB Model #			
Crank Model #	Mid BB	Spanish BB	Euro BB	American BB
BFC-18R/18S	AX05-MB-S	AX05-SB	AX05-EBA	AX05-ABA-S
BFC-12S/12R/12V/12U	AX05-MB			AX05-ABA
3PCS Cr Mo(8T)	Sealed BB Model #			
Crank Model #	Mid BB	Spanish BB	Euro BB	American BB
BFC-25S/25R/25V/25U	AX02-MB-S	AX02-SB	AX02-EBA	AX02-ABA-S
BFC-22H-2			AX02-1+BP901	AX07M+BP908



CW-1503C
 Description & Size:
 • CNC Process
 • Alloy Chaining
 • 25T
 • 1/2x1/8"(Standard), 1/2x3/32"
 • BK Or Color To Order



CW-1505C
 Description & Size:
 • CNC Process
 • Alloy Chaining
 • 25T
 • 1/2x1/8"(Standard), 1/2x3/32"
 • BK Or Color To Order

wilma

LI-Race • Hollow Carbon



WM-CB-R40

Integrated Outside Bearing PF30/GXP
 Chainring: 53/39T, 50/34T. Teeth 7075/T6 CNC
 Crank: Hollow carbon
 Length: 170, 172.5, 175mm
 BCD: 110mm

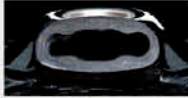

End boots for carbon cranks



WM-CB-525

Integrated outside bearing BB
 Chainring: 53/39T, 52/36T, 50/36T, 50/34T, 34/46T.
 Teeth 7075/T6 CNC
 Crank: Hollow carbon
 Length: 170, 172.5, 175mm
 BCD: 110mm



WM-CB-8001

Direct Mount Crankset
 Chainring: 28,30,32,34,36,38,40,42T. [MTB-05].
 For 9-12s
 Crank: Hollow Carbon
 Length: 170, 175mm
 For GXP / PF 30 crankset



WM-CB-M200

Integrated outside bearing. PF30/GXP. 9-12s
 Chainring: 42/28T, 40/28T, 38/24T, 36/22T
 Teeth alloy 7075/T6 CNC
 Crank: Hollow carbon
 Length: 170, 175mm
 BCD: 104/64mm



WM-CB-110NW OV

Integrated outside bearing BB
 Chainring: Narrow wide tooth 30, 32, 34, 36, 38T.
 7075/T6 CNC 9-12s
 Crank: Hollow Carbon
 Length: 170, 175mm
 BCD: 104mm

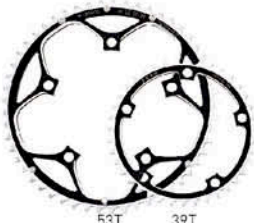

SS-9201 CNC

BCD: 130, 135mm
 Chainring: 38, 39, 40, 42, 48, 50, 52, 53, 54, 55, 56, 58T

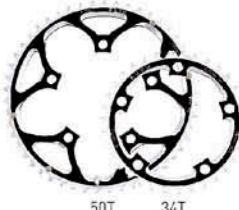

SS-9202 CNC

BCD: 110mm
 Chainring: 34, 36, 38, 40, 42, 46, 48, 50, 52, 53T



SS-9204 CNC OV

BCD: 110mm
 Chainring: 53/39T, 50/36T



SS-9205 CNC

For 9-12s, BCD: 110mm
 Chainring: 46T, 48T, 53/39T, 52/36T, 50/34T

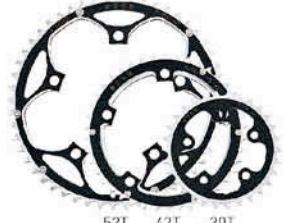

SS-9301 CNC

BCD: 130, 74mm
 Chainring: 52/42/30T, 52/39/30T



SS-9302 CNC [A]

BCD: 104, 64mm
 Chainring: 48/36/26T, 46/32/22T, 44/32/22, 42/32/24T, 42/32/22T



SS-9302 CNC [B]

BCD: 104, 64mm. For 9-11s
 Chainring: 48/36/26T, 46/32/22T, 44/32/22T, 42/33/24T, 42/32/22T



SS-9302-1

BCD: 104, 64mm. For 9-12s
 Chainring: 42/28T, 40/28T, 38/24T



SS-9303

BCD: 96, 64mm
 Chainring: 30/22T AL 7075/T6 CNC

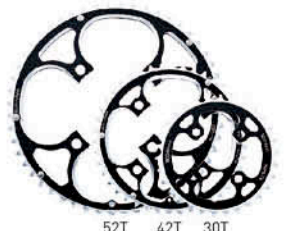

SS-9304 CNC

BCD: 104, 64mm. For 9-11s
 Chainring: 52/42/30T, 52/39/30T, 50/39/30, 46/39/30T



R-2000
Integrated outside BB
Chaining: 50/34T,53/39T.Teeth 7075/T6 alloy
Crank: Forged 6061/T6 alloy
Length: 165,170,172.5,175mm
BCD: 110mm



R-2002
Integrated outside BB
Chaining: 50/34T,53/39T.Teeth 7075/T6 alloy
Crank: Forged 6061/T6 alloy
Length: 165, 170, 172.5, 175mm



SS-8230 CNC-T1
Integrated outside bearing BB
Chaining: 53/39T, 53/36T, 52/39T.
Teeth 7075/T6 CNC
Crank: Forged 6061/T6 alloy
Length: 140, 152, 165, 170, 172.5, 175mm
BCD: 130mm



SS-8231 CNC-T2
Integrated outside bearing BB
Chaining: 52/36T, 50/36T, 50/34T, 48/34T, 46/34T. Teeth 7075/T6 CNC
Crank: Forged 6061/T6 alloy
Length: 140, 152, 165, 170, 172.5, 175mm
BCD: 110mm



ML-2200-T8 (Integrated)
Integrated BB 100mm.
For GXP/PF30 crankset
Chaining: 42/28T, 40/28T, 38/24T, 36/22T, 34/22T
Crank: Forged 6061/T6 alloy
Length: 170,175mm
BCD: 104/64mm



SS-8001
Direct mount crankset.
For GXP/PF30 crankset
Chaining: 28,30,32,34,36,38,40,42T. For 9-12s
Crank: Forged 6061/T6 alloy
Length: 152, 165, 170, 172.5, 175mm



SS-8002
Direct mount crankset.
For GXP/PF30 crankset
Chaining: 28,30,32,34,36,38,40,42T. For 9-12s
Crank: Forged 6061/T6 alloy
Length: 165, 170, 172.5, 175mm



SS-8316
Integrated outside BB
Chaining: 22/30T steel or alloy, 40T 6061/T6 alloy
Crank: Forged 6061/T6 alloy
Length: 170, 172.5, 175mm
BCD: 104/64mm



MTB-03
Narrow wide tooth. For 9-12s
BCD: 104mm.
Chaining: 30, 32, 34, 36, 38, 40, 42T
Chainline: 50.5mm. (48.5mm for 30T)



MTB-03-OV
Narrow wide tooth, oval chaining. For 9-12s
Chaining: 32,34T
BCD: 104mm



MTB-04
Direct mount, narrow wide tooth
Chaining. For 9-12s
Size: 28,30,32,34,36,38,40,42T



MTB-04-OV
Direct mount, narrow wide tooth, oval chaining. For 9-12s
Size: 28,30,32,34,36,38T



MTB-05
Direct mount, narrow wide tooth chaining. For GXP / BB30 crankset. For 9-12s
Size: 28, 30, 32, 34, 36, 38,40,42T



MTB-05-R
Direct mount, narrow wide tooth chaining. For RaceFace. For 9-12s
Size: 28,30,32,34,36,38,40,42T



MTB-06
BCD: 96mm
Chaining: 30,32,34,36T



MTB-94 A-02
Narrow wide tooth. For 9-12s
BCD: 94mm
Size: 30,32,34,36T

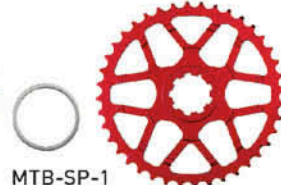

MTB-SP-1
Rear sprocket
Size: 40,42,45,46,48,49,50T



MTB-SP-1S
Size: 16,18T



BMX-ML-T8

Integrated outside bearing BB. For GXP/PF30 crankset
Chainring: 32,33,34,36,38,39T
Crank: Forged 6061/T6 alloy
Length: 165, 170, 175mm
BCD: 104mm



X3-3100NW-T7

Integrated outside bearing BB. For GXP/PF30 crankset.
Chainring: Narrow wide tooth 30, 32, 34, 36,38T.
Teeth 7075/T6 CNC. For 9-12s
Crank: Forged 6061/T6 alloy
Length: 170, 175mm
BCD: 104mm



SS-8108 CNC-B

Integrated Outside Bearing BB
Chainring: 44, 46, 48, 50, 52T. Steel or alloy
Crank: Forged 6061/T6 alloy
Length: 165, 170, 172.5, 175mm
BCD: 144mm



SS-8110 CNC-F

Integrated outside Bearing BB
Chainring: 46, 48T. Alloy
Crank: Forged 6066/T6 alloy
Length: 165, 170mm
BCD: 144mm



SS-8217

Chainring: 53/39T, 52/42T. Steel or alloy
Crank: Forged 6061/T6 alloy
Length: 170mm



SS-8219

Chainring: 50/34T, 2014/T6 CNC highlighted outer ring
Crank: Forged 6061/T6 alloy
Length: 165,170,175mm
BCD: 110mm
Axle length: 110.5mm



SS-8268A-T2

Chainring: 50/34T, 2014/T6 CNC highlighted outer ring
Crank: Forged 6061/T6 alloy
Length: 140, 152, 165, 170, 172.5, 175mm
BCD: 110mm
Axle length: 110.5mm



SS-8285A-T1

Chainring: 53/39T, 52/42T, 2014/T6 CNC highlighted outer ring
Crank: Forged 6061/T6 alloy
Length: 140, 152, 165, 170, 172.5, 175mm
BCD: 130mm
Axle length: 117.5mm



SS-8358A-T4

Chainring: 52/42/30T, 52/39/30T. CNC highlighted outer ring
Crank: Forged 6061/T6 alloy
Length: 170, 175mm
BCD: 130/74mm
Axle length: 117.5mm



SS-7349P-10

Steel triple chainwheel & plastic spider (4-arm) with alloy crank
Chainring: 48/38/28T
Crank: 165, 170mm



SS-7364P-1

Steel triple chainwheel & plastic spider (4-arm)with alloy crank cotterless crank
Chainring: 48/38/28T, 42/34/24T
Crank: 152, 165, 170mm
Chainline: 47.5mm
Axle length: 119mm



SS-7364P-12

Steel triple chainwheel & plastic spider (4-arm) with alloy crank
Chainring: 48/38/28T
Crank: 165, 170mm



SS-7365P-11

Steel triple chainwheel & plastic spider (4-arm) with alloy crank
Chainring: 48/38/28T
Crank: 165,170mm



SS-7943P-6

Steel triple chainwheel with chaincover & plastic spider (4-arm) with alloy crank cotterless crank
Chainring: 48/38/28T, 42/34/24T
Crank: 152, 165, 170mm
Chainline: 47.5mm
Axle length: 119mm



SS-8336-T3

Chainring: 48/38/28T, 46/34/24T, 44/32/22T, 42/32/22T
Crank: Forged 6061/T6 alloy
Length: 170, 175mm
BCD: 104/64mm



SS-8395

Chainring: 48/38/28T, 46/34/24T, 44/32/22T, 42/32/22T
Crank: Forged 6061/T6 alloy
Length: 170, 175mm
BCD: 104/64mm
Axle length: 113mm



SS-7100-1P

Chainring: 46, 48, 52T. Steel or alloy
Crank: Forged 6061/T6 alloy
Length: 170mm
Axle length: 107mm



SS-7881

Steel chainwheel with steel cotterless crank.
Chainring: 52, 110T
Crank: 170mm



SS-8131W

Steel or alloy chainwheel alloy chainwheel protector with alloy crank.
Chainring: 42, 44, 46, 48T
Crank: Alloy 170mm
BCD: 104 mm
Chainline: 50mm
Axle length: 113.5mm



SS-8101
Steel or alloy chainwheel with alloy crank.
Chainring: 36, 38, 39, 42, 44T
Crank: Alloy 165, 170, 175mm (5-arm)
BCD: 110mm
Chainline: 43mm
Axle length: 103mm



SS-8102
Steel or alloy chainwheel with alloy crank.
Chainring: 42, 44T
Crank: Alloy 165, 170mm
BCD: 110mm



SS-8106
Chainring: 39, 42, 44, 46, 48, 50, 52T.
Steel or alloy
Crank: Forged 6061/T6 alloy
Length: 165, 170, 175mm
BCD: 130mm
Chainline: 43mm
Axle length: 103mm



SS-8109
Chainring: 44, 46, 48, 50, 52T. Steel or alloy
Crank: Forged 6061/T6 alloy
Length: 165, 170, 172.5, 175mm
BCD: 144mm
Axle length: 103mm



SS-8110
Chainring: 44, 46, 48, 50, 52T. Alloy
Crank: Forged 6066/T6 alloy
Length: 165, 170mm
BCD: 144mm
Axle length: 103mm



SS-8110-F130
Chainring: 42, 44, 46T. Steel or alloy
Crank: Forged 6061/T6 alloy
Length: 165, 170mm
BCD: 130mm
Axle length: 103mm

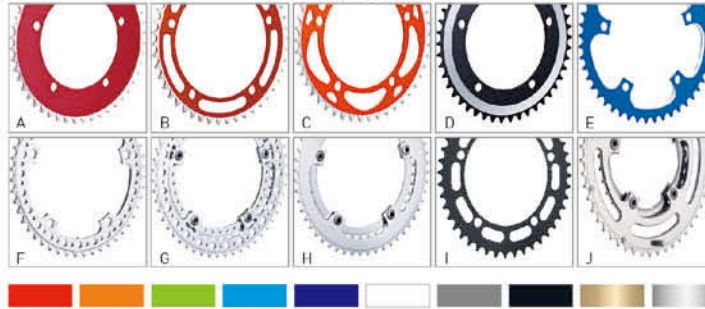

SS-110LK (A)
7075/T6 alloy
BC: 1.37-24TP



SS-LA01
M8x8.5-9.9x7L, M8x8.5-6.5x5L
Material: Alloy 7075/T6



SS-664
M15x1.0x13, M8x1.0x15
Material: Alloy 7075/T6



SL-665
M15x1.0x16.5
Material: Alloy 7075/T6



SS-666
M18x1.0x15



SS-110LK (B)
7075/T6 alloy
BC: 1.37-24TP



SS-110LT
7075/T6 alloy
BC: 1.29-24TP



SS-6613-6
Steel chainwheel with steel cotterless crank.
Chainring: 28, 30, 32, 36, 38T
Crank: 152, 165, 170mm
Chainline: 45mm
Axle length: 127.5mm



SS-6616
Steel chainwheel with steel cotterless crank.
Chainring: 26, 28, 32, 33T
Crank: 4", 5", 5-1/2"
Chainline: 45mm
Axle length: 120mm



SS-6616-2
Steel chainwheel with steel cotterless crank.
Chainring: 36, 38, 40, 42, 44, 46, 48, 52T
Crank: 5", 5-1/2", 6", 6-1/2", 170mm



SS-6626
Steel chainwheel & double chaincover with cotterless crank.
Chainring: 36, 38, 40, 44T
Crank: 5", 5-1/2", 6", 170mm
Chainline: 45mm
Axle length: 119mm



SS-803
Steel cotterless crank for exercisers.
Crank: Right & left cotterless
Length: 3-1/2", 4", 4-1/2", 5", 5-1/2", 6", 6-1/2", 170mm



E-100
Length: 170mm



SS-BMX-02
Steel hot forged crank arm
Crank: 170, 175mm



SS-BMX-03-1
Cr-mo 4130 seamless tube.
Crank: 140, 150, 160, 165, 170, 175mm



SS-BMX-06B
Cr-mo 4130 seamless tube
Crank: 175mm



SS-BMX-07
Steel hot forged crank arm
Crank: 175mm



SS-BMX-08
Steel hot forged crank arm
Crank: 170, 175mm



SS-518
Length: 138mm



SS-520
19 mm/8T cromoly spline
Length: 137mm



SS-521
19 mm/8T cromoly spline
Length: 150mm



SS-523
19 mm/8T Cromoly spline
Length: 135/150mm



SS-B3



SS-AD01
Eccentric BB Set
OD: Ø54,54.5mm. Alloy 6061/T6 CNC.
BC 1.37"
Weight: 200g



SS-524
19 mm/8T Cromoly spline
Length: 135/150mm



SS-024
BB.Parts



SS-905
BB. Parts set of 9 pcs (lucp) for one piece crank

SS-905A
BB. Parts set of 9 pcs (lucp) for one piece crank



SS-023
BB. Parts



SS-921
170,175mm



SS-922
170,175mm



SS-925
170,175mm



SS-926
170,175mm



SS-927
170,175mm



SS-928
175mm



SS-929
170,175mm



SS-901
3", 3-1/2", 4", 4-1/2",
5", 5-1/2", 6", 6-1/2"



SS-902
3", 3-1/2", 4", 4-1/2",
5", 5-1/2", 6", 6-1/2",
170, 175mm



SS-902-1
3-1/2", 4", 4-1/2", 5",
5-1/2", 6", 6-1/2",
170, 175mm

Alloy ceterless crank for exercisers.
Crank: Right & left

AL1 / 152, 165, 170mm
 AL2 / 127, 140, 152, 165, 170mm
 AL3 / 165, 170, 175mm
 AL4 / 170mm
 AL5 / 170mm
 AL6 / 170mm
 AL7 / 165, 170mm
 AL8 / 170mm
 AL9 / 165, 170, 172.5, 175mm
 AL10 / 170mm
 AL11 / 165, 170mm

SS-7001
Crank: Forged 6061/T6 alloy
Length: 170mm
Size: 1/8"x5 holes
Diam: Ø1.37

SS-7002
Crank: Forged 6061/T6 alloy
Length: 170mm
Size: 1/8"x5 holes
Diam: Ø1.37

SS-102 Teeth: 25T. Alloy
SS-103 Teeth: 25T. Alloy
SS-107 Teeth: 25, 26, 28, 30T. Steel
SS-108 Teeth: 25, 26, 30T. Alloy or steel
SS-109 Teeth: 25, 26, 28, 30T. Alloy or steel
SS-110 Teeth: 25, 26, 28, 30, 32, 36, 39T. Alloy or steel
SS-111 Teeth: 42, 44T. Alloy or steel
SS-112 Teeth: 44, 42T. Alloy or steel
SS-113 Teeth: 42, 44T. Steel or alloy
SS-114-1 Teeth: 43, 44T
SS-120 Teeth: 25T. Steel or alloy
SS-121 Teeth: 25T. Steel or alloy
SS-122 Teeth: 25T. Steel or alloy
SS-123 Teeth: 24, 25T. Steel or alloy
SS-124 Teeth: 25, 26, 28T. Steel or alloy
SS-125 Teeth: 24, 25, 26, 28T. Steel or alloy

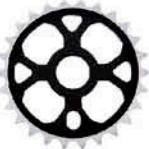

SS-126
Teeth: 25, 26, 28T.
Steel or alloy



SS-127
Teeth: 24, 25, 26, 28T.
Steel or alloy



SS-128
Teeth: 24, 25, 26, 28T.
Steel or alloy



SS-129
Teeth: 25, 26, 28, 30, 32, 33T. Steel or alloy



SS-131
Teeth: 43, 44T



SS-132
Teeth: 43T, 44T



SS-134
Teeth: 40, 42, 43, 44T



SS-135
Teeth: 40, 42, 43, 44T



SS-140
Teeth: 40, 42, 43, 44T



SS-141
Teeth: 43, 44T



SS-142
Teeth: 36, 38, 39, 42, 44T



SS-164
Teeth: 39, 40, 42, 43, 44T



SS-166
Teeth: 30, 32, 33, 36, 38, 39, 40, 44T



SS-180
Teeth: 36, 40, 44T



SS-191
Teeth: 44T



SS-234CNC-129
Teeth: 25T



SS-234CNC-166
Teeth: 36, 38T



SS-234CNC-388
Teeth: 44T



SS-315
Teeth: 43, 44T



SS-323H
Teeth: 43, 44T



SS-329
Teeth: 28, 32, 36, 40, 42, 43, 44, 46, 48, 52T



SS-334
Teeth: 39, 40, 42, 43, 44T



SS-336
Teeth: 44T



SS-337-1
Teeth: 43, 44T



SS-337-2B
Teeth: 43, 44T



SS-337-3
Teeth: 43, 44T



SS-338
Teeth: 40T



SS-339-1
Teeth: 43, 44T



SS-340A
Teeth: 44T



SS-359
Teeth: 43, 44T



SS-360
Teeth: 42, 43, 44T



SS-367
Teeth: 24, 26, 28, 32, 36, 40, 42, 43, 44, 46, 48, 52T



SS-410A
Teeth: 43, 44T



SS-412
Teeth: 43, 44T



SS-558
Teeth: 36, 40, 44T



SS-903
Teeth: 28, 32, 36, 38, 40, 42, 44, 46, 48, 52T



SS-903-10
Teeth: 40x48T



SS-903-15
Teeth: 28, 38, 48, 36, 42, 48T



SS-907
Teeth: 44T



SS-908
Teeth: 44, 46T



SS-908A
Teeth: 40, 42, 44, 46T



SS-913A
Teeth: 44T



SS-913B
Teeth: 44T
BCD: 110mm



SS-913C
Teeth: 34, 36, 38, 39, 40, 41, 42T
BCD: 110mm



SS-918
Teeth: 43, 44T



SS-933
Teeth: 43, 44, 46T



SS-941
Teeth: 36, 44T



SS-953
Teeth: 44T



SS-953A
Teeth: 44T



SS-953B
Teeth: 43, 44T



SS-956
Teeth: 43, 44T



SS-957
Teeth: 36, 40, 44, 46T



SS-959B
Teeth: 43, 44T



SS-983
Teeth: 24, 26, 28, 32, 36, 40, 42, 43T, 44, 46, 48, 52T



SS-983-1
Teeth: 36, 40, 43, 44T



SS-988
Teeth: 28, 32, 36, 40, 42, 44, 46T

Chain wheel line-up 2019



Model name	AURON-BT	AURON	AION-BT	AION	ZERON 1X-BT
Crank Length (mm)	Carbon - 170/175	Carbon - 170/175	Alloy - 170/175	Alloy - 170/175	Alloy - 170/175
Chain line (mm)	53	50	53	50	53
Material and Teeth	Wave Ring 30 Wave Ring 32 Wave Ring 34	Wave Ring 30 Wave Ring 32 Wave Ring 34	Wave Ring 28 Wave Ring 30 Wave Ring 32 Wave Ring 34	Wave Ring 28 Wave Ring 30 Wave Ring 32 Wave Ring 34	ZigZag Steel 28 ZigZag Steel 30 ZigZag Steel 32
Compatible Speed	10s/11s	10s/11s	10s/11s	10s/11s	10s/11s



Model name	ZERON 1X	ZERON 2X-BT	ZERON 2X	XCD-D	XCD-S
Crank Length (mm)	Alloy - 170/175	Alloy - 170/175	Alloy - 170/175	Alloy - 170/175	Alloy - 170/175
Chain line (mm)	50	52	49	50	50
Material and Teeth	ZigZag Steel 30 ZigZag Steel 32	Alloy 38 - Steel 24 Steel 36 - Steel 22	Alloy 38 - Steel 24 Steel 36 - Steel 22	Alloy 38 - Steel 28	Steel 30
Compatible Speed	10s/11s	10s	10s	9s	9s/10s
Suggested BB	-	-	-	FG (Full Guard)	FG (Full Guard) DG (Double Guard)



Model name	XCM-T	XCT9-T	XCE-T	XCE-JR-T	XCC-T
Crank Length (mm)	Alloy - 170/175	Alloy - 170/175	Alloy - 160/170/175	Alloy - 152/160	Alloy - 170/175
Chain line (mm)	50	49.3	48	48	48
Material and Teeth	Alloy 48 - Steel 36 - Steel 26 Alloy 44 - Steel 32 - Steel 22 Alloy 40 - Steel 30 - Steel 22 Steel 48 - Steel 36 - Steel 26 Steel 44 - Steel 32 - Steel 22 Steel 40 - Steel 30 - Steel 22	Alloy 44 - Steel 32 - Steel 22 Alloy 48 - Steel 36 - Steel 26 Steel 44 - Steel 32 - Steel 22 Steel 48 - Steel 36 - Steel 26	Alloy 48 - Steel 38 - Steel 28 Alloy 42 - Steel 34 - Steel 24 Steel 48 - Steel 38 - Steel 28 Steel 42 - Steel 34 - Steel 24	Alloy 48 - Steel 38 - Steel 28 Alloy 42 - Steel 34 - Steel 24 Steel 48 - Steel 38 - Steel 28 Steel 42 - Steel 34 - Steel 24	Steel 48 - Steel 38 - Steel 28 Steel 42 - Steel 32 - Steel 22 Steel 42 - Steel 34 - Steel 24
Compatible Speed	Alloy-Steel-Steel: 10s Steel-Steel-Steel: 9s	9s	8s	8s	7s / 8s
Suggested BB	BG (Black Guard) SG (Silver Guard)	-	BG (Black Guard) SG (Silver Guard)	BG (Black Guard) SG (Silver Guard)	IBG (Integrated Black Guard)



www.srsuntour-cycling.com

TAIWAN
SR Suntour Inc.
#7 Hsing Yeh Rd
Fu Hsing Industrial Zone
ChangHua 506
Tel. +886-4-7695115
Fax +886-4-7694028

CHINA
SR Suntour (Shenzhen) Inc.
Suibei Industrial Zone Subei Rd
Gongming Town, Guangming District
ShenZhen China
Tel. +86-755-27105533
Fax +86-755-27105633

CHINA
SR Suntour Machinery Inc.
1500 Honghu Rd, PengLang,
KunShan Development Zone
JiangSu Province China 215333
Tel. +86-512-5518-8088
Fax +86-512-5517-1117

VIETNAM
SR SUNTOUR VIETNAM CO., LTD
Lot. 17-8, Street 3B,
Protrade International Tech Park,
An Tay commune, Ben Cat Town,
Binh Duong Province, Viet nam.
Tel: +84-274-3721-883

TOTAL SOLUTION FOR BELT DRIVE SYSTEM



專業提供

皮帶傳動系統 解決方案

Belt

ISO 4210-8 Approved



848,1000,1120,1168,1200,1240
1264,1280,1304,1312,1344,1368,1400
length can be customized

Chain wheel

ISO 4210:2014 APPROVED



AL鋁合金:65T,70T,72T,78T,80T
PPA塑鋼:48T,60T,66T,80T

Rear wheel

JIS D9418 Approved



AL鋁合金:28T,30T,Free wheel
PPA塑鋼:28T,30T



TOPTRANS®

www.toptransco.com

捷翰有限公司
TOPTRANS COMPANY LTD.

Head Quarter

Tel:+886-2-26983688

Fax:+886-2-26983799

Taichung Office

Tel:+886-4-26822558

Fax:+886-4-26822858

toptrans@ms75.hinet.net

Taiwan Bicycle Source 2018-2019



WELLTRANS®

www.shwelltrans.com

威全傳動系統貿易(上海)有限公司
WELLTRANS TRANSMISSION
SYSTEM(SHANGHAI) CO.,LTD.

Shanghai Office

Tel:+86-21-59102920

Fax:+86-21-59102808

sales@welltransco.com

Dongguan Office

Tel:+86-769-82888708

Fax:+86-769-85551798

gordon.chen@welltransco.com



UF-304



UF-306



UF-302



UF-303



UF-301



UF-305



Soft Cushion
UF-351
for EMTB



UG-601



UG-602



UG-603



UG-604

UG-101



UG-101B



UG-102



UG-102B



UG-101C

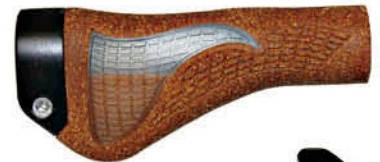

UG-101BC



30mm SPINDLE CRANK

ROAD Crank



C-101



C-102

MTB Crank



C-131T
for Triple



C-131SD
for Single/Double

OVAL CHAINRINGS

ROAD Oval Chaining



E2-01

MTB Oval Chaining



E3-03
42/33/24T
Close Ratio Gear



E2-09
For both
4-arm & 5-arm spider



E2-03
38/24T, 36/22T

Oval Narrow/Wide Single Chaining



E1-03
104 BCD



E1-06
96 BCD
for XT M8000



E1-07
96 BCD
for XTR M9000



E1-04(BOOST)
Direct Mount



E1-05
Direct Mount



MPX12-36T-TT

CRANK LENGTH: 170,175MM
 MATERIAL: FORGED AL. 6061-T6
 FINISH: BLACK SAND ANO.
 CHAINRING: 38T,36T,34T,32T,30T,
 28T,26T,24T
 MATERIAL: AL-7075-T6
 FINISH: BLACK SAND ANO.
 COMPATIBILITY: 12S
 CHAINLINE: 49MM
 QI-FACTOR: 175/145MM
 BB SETS: PW-BB73+ / PW-BB92

MPX12-36T-TT-B

CHAINRING: 38T,36T,34T,32T,30T,
 28T,26T,24T
 CHAINLINE: 52MM



CHARM-36T-TT

CRANK LENGTH: 170,175MM
 MATERIAL: FORGED AL. 6061-T6
 FINISH: BLACK SAND ANO.
 CHAINRING: 38T,36T,34T,32T
 MATERIAL: AL-7075-T6
 FINISH: BLACK SAND ANO.
 COMPATIBILITY: 11S
 CHAINLINE: 50MM
 BCD: 104MM
 QI-FACTOR: 175/145MM
 BB SETS: PW-BB73+ / PW-BB92

CHARM-36T-TT-B

CHAINRING: 38T,36T,34T,32T
 CHAINLINE: 53MM



CHARM-32T-TT

CRANK LENGTH: 170,175MM
 MATERIAL: FORGED AL. 6061-T6
 FINISH: BLACK SAND ANO.
 CHAINRING: 34T,32T,30T,28T,26T
 MATERIAL: STEEL
 FINISH: BED
 COMPATIBILITY: 11S
 CHAINLINE: 50MM
 BCD: 76MM
 QI-FACTOR: 175/145MM
 BB SETS: PW-BB73+ / PW-BB92

CHARM-32T-TT-B

CHAINRING: 34T,32T,30T,28T,26T
 CHAINLINE: 53MM



CLAW-581-TT

CRANK LENGTH: 170,175MM
 MATERIAL: FORGED AL. 6061-T6
 FINISH: BLACK SAND ANO.
 CHAINRING: 38-28T/36-26T
 MATERIAL: AL-7075-T6
 FINISH: 100% CNC MACH.
 BLACK SAND ANO.
 COMPATIBILITY: 11S
 CHAINLINE: 49MM
 BCD: 104/64MM
 QI-FACTOR: 176/146MM
 BB SETS: PW-BB73+ / PW-BB92

CLAW-581-TT-B

CHAINRING: 38-28T/36-26T
 CHAINLINE: 52MM



MPL-971-TT

CRANK LENGTH: 170,175MM
 MATERIAL: FORGED AL. 6061-T6
 FINISH: BLACK SAND ANO.
 CHAINRING: 40-30-22T
 MATERIAL: 40T: AL-7075-T6,
 30-22T: STEEL
 FINISH: 40T: CNC DETAIL,
 BLACK SAND ANO.
 30-22T: BED
 COMPATIBILITY: 11S
 CHAINLINE: 50MM
 BCD: 96/64MM
 QI-FACTOR: 174.3/144.3MM
 BB SETS: PW-BB73



MPL-961-TT

CRANK LENGTH: 170,175MM
 MATERIAL: FORGED AL. 6061-T6
 FINISH: BLACK SAND ANO.
 CHAINRING: 40-30-22T
 MATERIAL: 40T: ALLOY
 30-22T: STEEL
 FINISH: 40T: BLACK SAND ANO.
 30-22T: BED
 COMPATIBILITY: 11S
 CHAINLINE: 50MM
 BCD: 96/64MM
 QI-FACTOR: 174.3/144.3MM
 BB SETS: PW-BB73



MPL-651-TT

CRANK LENGTH: 170,175MM
 MATERIAL: FORGED AL. 6061-T6
 FINISH: BLACK SAND ANO.
 CHAINRING: 42-32-24T
 MATERIAL: 42T: ALLOY
 32-24T: STEEL
 FINISH: 42T: CNC DETAIL,
 BLACK SAND ANO.
 32-24T: BED
 COMPATIBILITY: 10S
 CHAINLINE: 50MM
 BCD: 104/64MM
 QI-FACTOR: 176/146MM
 BB SETS: PW-BB73+ / PW-BB92



MTB BOTTOM BRACKETS



PW-BB73
 BB SHELL WIDTH: 68/73MM FOR MTB
 BB MODEL NO.: PW-BB73
 BB COMPATIBILITY: 8CL37*24T BB CUPS WITH
 Ø24MM SPINDLE
 BEARING CUP: ALLOY, FORGED AND CNC MACH.
 EXTERNAL BLACK ANO. CUPS WITH
 LASER LOGO
 CENTER SLEEVE: PLASTIC BLACK



PW-BB73+
 BB SHELL WIDTH: 68/73MM FOR MTB
 BB MODEL NO.: PW-BB73+
 BB COMPATIBILITY: 8CL37*24T BB CUPS WITH
 Ø24MM SPINDLE
 BEARING CUP: ALLOY, FORGED AND CNC MACH.
 EXTERNAL BLACK ANO. CUPS WITH
 LASER LOGO
 CENTER SLEEVE: PLASTIC BLACK



PW-BB92
 BB SHELL WIDTH: 89.5/92MM FOR MTB
 BB MODEL NO.: PW-BB92
 BB COMPATIBILITY: WITH Ø24MM SPINDLE
 BEARING CUP: PA+GF BLACK, INJECTION
 CENTER SLEEVE: PLASTIC BLACK

PRO WHEEL

WWW.PRO-WHEEL.COM

WHOLE MAN ENTERPRISE (TAIWAN) CO., LTD.
 浩盟企業股份有限公司
 TEL:886-6-2825791/92 FAX:886-6-2825746
 E-MAIL:SALES-TW@PRO-WHEEL.COM
 HAOMENG BICYCLE (SHANGHAI) CO., LTD.
 浩盟車料(上海)有限公司
 TEL:86-21-57532846/47 FAX:86-21-57536961
 E-MAIL:SALES-SH@PRO-WHEEL.COM
 WHOLE MAN ENTERPRISE (TIANJIN) CO., LTD.
 浩盟車料精銳科技(天津)有限公司
 TEL:86-22-66321818 FAX:86-22-66321820
 E-MAIL:SALES-TJ@PRO-WHEEL.COM



RPX11-44T-TT-1

CRANK LENGTH: 170,172.5,175MM
 MATERIAL: FORGED AL-6061-T6
 FINISH: HP BLACK ANO.
 CHAINRING: 50T,48T,46T,44T,42T
 40T,38T
 MATERIAL: AL-7075-T6
 FINISH: 100% CNC MACH.
 BLACK SAND ANO.
 COMPATIBILITY: 11S
 BCD: 110MM
 CHAINLINE: 45.5MM
 QI-FACTOR: 153/124MM
 BB SETS: PW-BB68+ / PW-BB66



RPT-721-TT-1

CRANK LENGTH: 170,172.5,175MM
 MATERIAL: FORGED AL-6061-T6
 FINISH: HP BLACK ANO.
 CHAINRING: E3-39T/50-34T
 MATERIAL: AL-7075-T6
 FINISH: 100% CNC MACH.
 BLACK SAND ANO.
 COMPATIBILITY: 11S
 BCD: 110MM
 CHAINLINE: 43.5MM
 QI-FACTOR: 153/124MM
 BB SETS: PW-BB68+ / PW-BB66



RPX11-621C-TT-1

CRANK LENGTH: 170,172.5,175MM
 MATERIAL: FORGED AL-6061-T6
 FINISH: HP BLACK ANO.
 CHAINRING: 53-39T/50-34T
 MATERIAL: ALLOY
 FINISH: 100% CNC MACH.
 BLACK SAND ANO.
 COMPATIBILITY: 11S
 BCD: 110MM
 CHAINLINE: 43.5MM
 QI-FACTOR: 153/124MM
 BB SETS: PW-BB68+ / PW-BB66



VICTOR-621C-TT

CRANK LENGTH: 170,172.5,175MM
 MATERIAL: FORGED AL-6061-T6
 FINISH: HP BLACK ANO.
 CHAINRING: 50-34T
 MATERIAL: ALLOY
 FINISH: 100% CNC MACH.
 BLACK SAND ANO.
 COMPATIBILITY: 10S
 BCD: 110MM
 CHAINLINE: 43.5MM
 QI-FACTOR: 158/128MM
 BB SETS: PW-BB68



RPL-521-TT

CRANK LENGTH: 165,170,
 172.5,175MM
 MATERIAL: FORGED AL-6061-T6
 FINISH: BLACK POWDER COAT
 CHAINRING: 50-34T/48-32T
 48-34T/46-32T
 46-30T
 MATERIAL: STEEL
 FINISH: BED
 COMPATIBILITY: 11S,10S
 BCD: 110MM
 CHAINLINE: 43.5MM
 QI-FACTOR: 161/132MM
 BB SETS: PW-BB68+ / PW-BB66



RPL-421

CRANK LENGTH: 165,170,
 172.5,175MM
 MATERIAL: FORGED AL-6061-T6
 FINISH: BLACK POWDER COAT
 CHAINRING: 48-32T/46-32T
 46-30T
 MATERIAL: STEEL
 FINISH: BED
 COMPATIBILITY: 9S,8S
 BCD: 110/80MM
 CHAINLINE: 43.5MM
 QI-FACTOR: 161/132MM
 BB SETS: 116MM



RPE-421P

CRANK LENGTH: 165,170,175MM
 MATERIAL: FORGED AL-6061-T6
 FINISH: BLACK POWDER COAT
 CHAINRING: 50-34T
 MATERIAL: STEEL
 FINISH: BED
 COMPATIBILITY: 8S,7S
 CHAINLINE: 45MM
 CHAINRING: PLASTIC BLACK
 QI-FACTOR: 169/141MM
 BB SETS: 119MM



ROAD BOTTOM BRACKETS



PW-BB68
 BB SHELL WIDTH: 68MM FOR ROAD
 BB MODEL NO.: PW-BB68
 BB COMPATIBILITY: BCL37*24T BB CLIPS WITH
 Ø24MM SPINDLE
 BEARING CUP: ALLOY, FORGED AND CNC MACH.
 EXTERNAL METAL GREY ANO. CLIPS
 WITH LASER LOGO
 CENTER SLEEVE: PLASTIC TRANSPARENT



PW-BB68+
 BB SHELL WIDTH: 68MM FOR ROAD
 BB MODEL NO.: PW-BB68+
 BB COMPATIBILITY: BCL37*24T BB CLIPS WITH
 Ø24MM SPINDLE
 BEARING CUP: ALLOY, FORGED AND CNC MACH.
 EXTERNAL METAL GREY ANO. CLIPS
 WITH LASER LOGO
 CENTER SLEEVE: PLASTIC GREY



PW-BB86
 BB SHELL WIDTH: 86MM FOR ROAD
 BB MODEL NO.: PW-BB86
 BB COMPATIBILITY: WITH Ø24MM SPINDLE
 BEARING CUP: PA+GF GREY, INJECTION
 CENTER SLEEVE: PLASTIC GREY



MIDTOWN-253Y-TT-1

CRANK LENGTH: 170MM
 MATERIAL: FORGED AL-6061-T6
 FINISH: HP BLACK AND.
 CHAINRING: 53T
 MATERIAL: ALLOY
 FINISH: BLACK SAND AND.
 BCD: 130MM
 CHAINLINE: 45MM
 CHAINGUARD: ALLOY,CNC DETAIL,
 BLACK SAND AND.
 QI-FACTOR: 158/129MM
 BB SETS: PW-BB88+ / PW-BB88



MIDTOWN-253A-TT-1

CRANK LENGTH: 170MM
 MATERIAL: FORGED AL-6061-T6
 FINISH: HP BLACK AND.
 CHAINRING: 53T
 MATERIAL: ALLOY
 FINISH: BLACK SAND AND.
 BCD: 130MM
 CHAINLINE: 45MM
 QI-FACTOR: 158/129MM
 BB SETS: PW-BB88+ / PW-BB88



RPL-242AA

CRANK LENGTH: 165,170,
 172.5,175MM
 MATERIAL: FORGED AL-6061-T6
 FINISH: BLACK SAND
 POWDER COAT
 CHAINRING: 42T
 MATERIAL: ALLOY
 FINISH: BED
 BCD: 110MM
 CHAINLINE: 43.5MM
 CHAINGUARD: DOUBLE ALLOY,
 BLACK SAND AND.
 QI-FACTOR: 161/132MM
 BB SETS: 122MM



PRO-A36(110-92)

CRANK LENGTH: 165,170MM
 MATERIAL: FORGED AL-6061-T6
 FINISH: SILVER PAINTED
 CHAINRING: 46T,44T,42T,40T,38T,
 36T,33T,32T,31T
 MATERIAL: STEEL
 FINISH: SILVER
 DISK: PLASTIC SILVER
 QI-FACTOR: 175/148MM
 BB SETS: 119MM



RA105PP

CRANK LENGTH: 79,89,102,114,
 127,140,152,
 160MM
 MATERIAL: FORGED AL-6061-T6
 FINISH: SILVER PAINTED
 CHAINRING: 36T,32T,31T
 MATERIAL: STEEL
 FINISH: SILVER
 CHAINLINE: 45MM
 CHAINGUARD: DOUBLE PLASTIC
 SILVER
 QI-FACTOR: 170/141MM
 BB SETS: 126MM



PRO-V32/36PP

CRANK LENGTH: 102,110,127,130,
 140,145,152MM
 MATERIAL: FORGED AL-6061-T6
 FINISH: SILVER PAINTED
 CHAINRING: 32T,36T
 MATERIAL: STEEL
 FINISH: SILVER
 CHAINLINE: 45MM
 CHAINGUARD: DOUBLE
 PLASTIC,SILVER
 QI-FACTOR: 175/148MM
 BB SETS: 119MM



RA105PP

CRANK LENGTH: 79,89,102,114,
 127,140,152,
 160MM
 MATERIAL: FORGED AL-6061-T6
 FINISH: SILVER PAINTED
 CHAINRING: 28T
 MATERIAL: STEEL
 FINISH: SILVER
 CHAINLINE: 45MM
 CHAINGUARD: DOUBLE PLASTIC
 SILVER
 QI-FACTOR: 170/141MM
 BB SETS: 126MM



PRO-Q38PP-1

CRANK LENGTH: 160,165,170MM
 MATERIAL: FORGED AL-6061-T6
 FINISH: SILVER PAINTED
 CHAINRING: 38T
 MATERIAL: STEEL
 FINISH: SILVER
 CHAINLINE: 45MM
 CHAINGUARD: DOUBLE PLASTIC
 SILVER
 QI-FACTOR: 171/142MM
 BB SETS: 119MM



PROWHEEL E-BIKE CRANK



EB03-D3-R-ISIS
EB03-L-ISIS

LENGTH: 165,170,172,5,175MM
FINISH: BLACK SAND POWDER COAT
WEIGHT: 495G (PAIR)



ASSEMBLY DRAWING

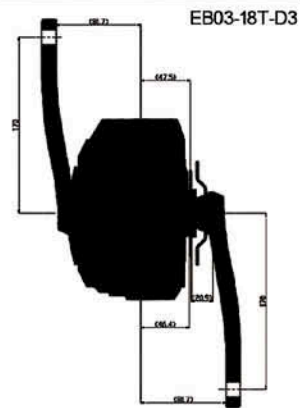

PROWHEEL SPIDER

SPIDER : D3
MATERIAL: AL-6061-T6
FINISH: BLACK SAND ANO.



PROWHEEL STEEL CHAINRING

FD07-16T/18T
CHAINRING MATERIAL: STEEL
CHAINRING FINISH: BED

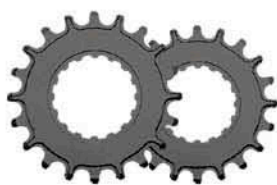

PROWHEEL SPINDLE BOLT

CrMo M5
WEIGHT : CrMo: 468G(PAIR)



MODEL NUMBER



MODEL	CRANK	SPIDER	CHAINRING	CHAINGUARD	DISK	CL	BCD
EB03-18T-D3	EB03	X	16T,18T	X	D3	47.5	X

PROWHEEL E-BIKE CRANK



EB04-R-BN
EB04-L-RN

LENGTH: 165,170,172,5,175MM
FINISH: BLACK SAND POWDER COAT
WEIGHT: 460G (PAIR)



ASSEMBLY DRAWING

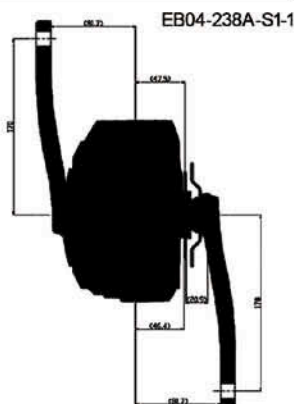

MODEL NUMBER

EB04-238A-S1-1



PROWHEEL SPIDER

AG62
CHAINGUARD MATERIAL: ALLOY
CHAINGUARD FINISH: BLACK SAND ANO.
FOR CHAINRING: 38T
BCD: 104MM

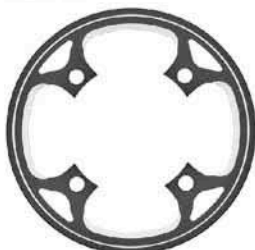

PROWHEEL STEEL CHAINRING

PRO-38T-1
CHAINRING MATERIAL: STEEL
CHAINRING FINISH: BED
BCD: 104MM



PROWHEEL SPIDER

SPIDER: S1-1(13T)
MOUNTING INTERFACE: 13T
MATERIAL: AL-6061-T6
FINISH: BLACK SAND ANO.
BCD: 104MM



PROWHEEL SPINDLE BOLT

CrMo M10
WEIGHT : CrMo: 45G(PAIR)



MODEL NUMBER



MODEL	CRANK	SPIDER	CHAINRING	CHAINGUARD	DISK	CL	BCD
EB04-238A-S1-1	EB04	S1-1	PRO-38T-1	AG62	X	47.5	104



PEAKBUYER CO., LTD.

No.42-5, Ln. 855, Yuancao Rd., Yuanlin City, Changhua County 51059, Taiwan

TEL:+886-4-8362464 / FAX:+886-4-8367464

www.ats-speeddrive.com Email:sales@ats-speeddrive.com



SD165



SD250

Internal Geared Crankset

ATS-speed drive - SD165 / SD250

- Incl. chainring, crankarms, (Option: kickplate)
- Gear ratio: SD165 (SD250) - 100% & 165% (250%)
- Axle length: 140 / 150 / 170 / 190 mm
- Chain Line: 30~56mm, adjustable.
- Chain ring: from 22T(SD165)/19T(SD250)~any teeth.
- Chain guard: Option, silver or black.
- Shifting mode: by hand (T) or by heel (H).



Chain Ring & Chain Guard

- BCD : 110mm
- CNC Alloy / 7075 / T6
- Teeth: (a)For SD165 : 22/27/34/36/38/40/44/50/54/60 T.
(b)For SD250:19T~ 54T (to order)
- Finish: sand blast black & silver anodized

Cranks & Kickplates

Cranks

- Forged alloy 6061
- Length : 155/160/165/170mm
- Finish : high polish silver / black anodized



Kickplate

- Alloy 6061
- Length : 155/160/165/170mm
- Finish : silver / black anodized

Maintenance

C-spanner(B) for adjust gearing play and hold gear shifting button(C) when being tightened. 1.5mm allen wrench(D) for tightening gear shifting button. MoS2 injector(E) for lubrication.

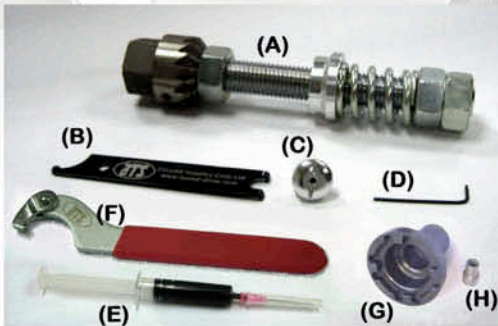

Tools

Milling cutter(A) for chamfering the bottom bracket (for cone installation) required.

Multi-C spanner(F) for BB nut on left side and adjust gearing play.

Box spanner(G) for BB nut on left side.

Small tube(H) for disassemble crank arm (prevent from shifting shaft bend or break)



ATS - shaft drive

- RC size: 460mm(700C,28") / 440mm(26") / 385mm(20") / 355mm(16")
- Any other size, please contact us.
- Shimano inter-3 / 7 / 8 / Alfine11
- Single speed available.
- Coaster brake, roller brake, V-brake available.



ATS - belt drive

- CNC Alloy / 7075 / T6
- Front wheel Teeth: 45T ~any teeth (for 8M belt drive)
- Rear wheel Teeth: 25 / 32 / 35T
- Finish : black or silver anodized
- PAT No.: 201520544267.7 / M511467



Cable Guide

- 1 hole / 2 holes / none hole (hole cover)
- Thickness: for 2mm / 2.5mm / 3mm

A&G

www.bikenews.online

BIKE MARKET UPDATE

Read To Win!

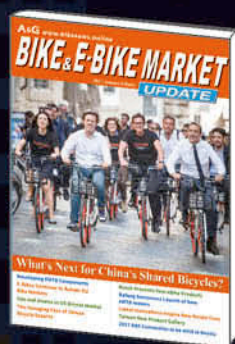

Information on industry and market news from Taiwan,
Mainland China and the world.

Published in English (twice a year) and in Chinese, BMU
brings you the most thorough reports and information on
the business hotspots of the world.



輪彥國際有限公司
WHEEL GIANT INC.



軟實力傳媒有限公司
Soft Power Media Co., Ltd.

No. 193, Tzu-Chiang Rd., Changhua 50095, Changhua, Taiwan / Tel: 886-4-7350500, 7360794-5
Fax: 886-4-7357860 / E-mail: rep@mail.wheelgiant.com.tw / Website: www.bikenews.online
Shanghai 86-512-57515789 / Ningbo 86-574-88210669 / Tianjin 86-22-28137963 / Shenzhen 86-755-28069189



B|LABS



Drivetrain Tech Solution Inc.

No.6, Aly.25, Ln.2, Sec. 1, Zhongxing Rd.,
Dail Dist., Taichung City 41267, Taiwan.

Tel: +886-4-24919555 Fax: +886-4-24910348

586

blabs@cycledrive.com

Taiwan Bicycle Source 2018-2019





CYCLE DRIVE SYSTEMS

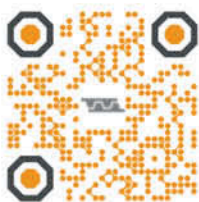

Drivetrain Tech Solution Inc.

No.6, Aly.25, Ln.2, Sec. 1, Zhongxing Rd.,
Dail Dist., Taichung City 41267, Taiwan.

Tel: +886-4-24919555

Fax: +886-4-24910348

OEMsale@cycledrive.com

<http://cycledrive.com/>



Color:
 Ti-N(Gold), Silver, Gold (X8), Ti-N/Jet Black(X12),
 Silver/Black(X11, X10), Black(X11EL, X10EL)

Compatibility:
 SRAM 12 speed drivetrain systems,
 SHIMANO, Campagnolo and SRAM 11/10 speed
 drivetrain systems.



Specification:

- New Double Elongated X Bridge Shape
- Extra StretchProof Hollow Pin
- Weight and Chain Suck Reduction
- Dynamic Chamfer Angles Design

eBike



Size: 1/2"x11/128". 1/2"x3/32". 1/2"x1/8"



Multiple speed: e11/e10/e9 Turbo, e11/e10/e9 Sport
Single speed: e101, e1, Z1eHX (Wide/ Narrow)
Color: Silver(e11/e10/e9 Turbo, e101, e1, Z1eHX Wide/Narrow),
 Silver/Black(e11/e10/e9 Sport, e1), Gold(e101, e1)

Specification:

- Compatible with BOSCH e-Bike system and other e-Bike system
- Highest Pin Power
- Highest Torsion Resistance
- High Tensile Strength
- Double X Bridge Shape
- Triple X Durability
- Non-directional
- Front single chainring only

ECO PROTECQ



Size: 1/2"x11/128". 1/2"x3/32". 1/2"x1/8"



Multiple speed: X12, X11, X10, X9, X8, e11/e10/e9 Turbo,
e11/e10/e9 Sport, Z9, Z8.3, Z8.1, Z7
Single speed: e101, e1, Z1eHX(Wide/ Narrow),
Z1(Wide/ Narrow), B1H Wide

Specification:

- Superior Corrosion Resistance
- Superior anti-rust and corrosion capabilities
- Environmentally Friendly Coating
- 650 hours in a Salt Spray Test
- Durable Coating
- Attractive Finish
- Able to Maintain Performance in the Harshesht Environments



LifeStyle



Size: 1/2"x11/128". 1/2"x3/32". 1/2"x1/8"



* 13 colors are available by request

RB Series



Size: 1/2"x11/128". 1/2"x3/32". 1/2"x1/8"



Multiple speed: Z9, Z8.3, Z8.1, Z7, Z6
Single speed: Z1(Wide/ Narrow), S1, B1H Wide, B1(Wide/ Narrow)
Compatible Bikes: Internal Gear Hub System, Beach Cruiser, BMX, Freestyle

Specification:

- Anti-Rust Capacity: Salt spray testing over 500hrs; case test rating above No.9.



DLC CHAIN



Color: DLC, DLC/Blue, DLC/Yellow, DLC/Red, DLC/Orange, DLC/Green



Compatibility:

SRAM 12 speed drivetrain systems.
SHIMANO, Campagnolo and SRAM 11/10 speed drivetrain systems.

Specification:

- Diamond Durability
- Titanium Carbon Nitride Tech
- High Alloy Steel Material
- Hydraulic Riveting
- Hollow Tech

Z Series

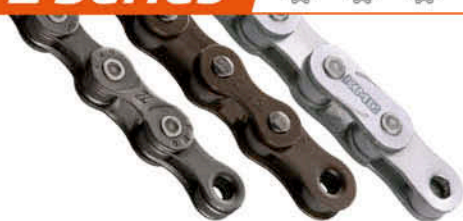

Size: 1/2"x11/128".
1/2"x3/32". 1/2"x1/8"

Multiple speed: Z9, Z8.3, Z8.1, Z7, Z6
Single speed: Z1eHX(Wide/ Narrow), Z1(Wide/ Narrow), S1
Color: Gray(Z9, Z8.3, Z8.1, Z6), Gray/Brown (Z7), Silver(Z1eHX Wide/ Narrow), Brown(Z1 Wide/ Narrow, S1)

Specification:

- StretchProof Mushroomed Pin, enhanced durability(Z9, Z1eHX Wide/ Narrow)
- HeavyDuty(Z1eHX Wide/ Narrow)
- Anti-Drop design (Z1eHX Wide/ Narrow, Z1 Wide/ Narrow)

K Series

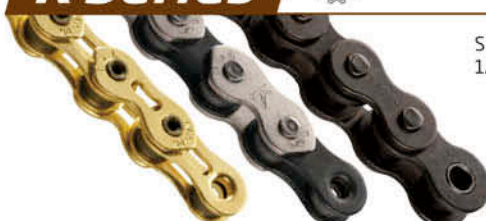

Size: 1/2"x 3/32".
1/2"x1/8". 1/2"x3/16"

Single speed: K1SL(Wide/ Narrow), K1(Wide/ Narrow), K415H
Color: Gold(K1SL Wide/ Narrow), Silver, Silver/Black(K1 Wide/ Narrow), Gray(K415H)

Compatible Bikes: BMX, Freestyle, Beach Cruiser

Specification:

- Special Dynamic Configuration Plates (exclude K415H)
- Light Weight & StretchProof Hollow Pin (KSL)
- Anti-Drop design
- StretchProof Mushroomed Pin, enhanced durability.

SHIMANO

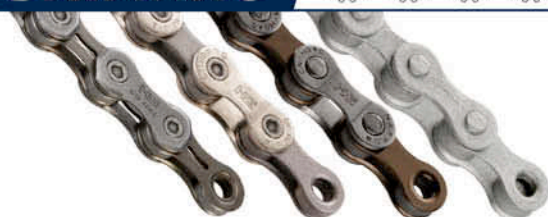

Multiple speed: CN4601. HG73B. HG53. HG71. HG40
Single speed: CN-NX10
Color: Gray/Brown, Silver/Gray, Gray
Compatible with Shmano HG System. Licensed by Shimano.

HALFLINK



Size: 1/2"x 3/32". 1/2"x1/8"



Single speed: KK710, HL1L Wide, HL1(Wide / Narrow)
Color: Gold(HL1L Wide, HL1 Wide / Narrow), Silver
Compatible Bikes: BMX, Freestyle

Specification:

- Half Link Design
- Unique "L" type of surface design (KK710)
- Light Weight & StretchProof Hollow Pin (HL1L Wide / Narrow)



Connecting Link



MISSINGLINK
reusable & non-reusable



SLOTTED LINK



SPRING CLIP CL



SNAP ON CL



OFFSET LINK-1 PITCH



OFFSET LINK-2 PITCH



BULLET PIN



KMC CHAIN INDUSTRIAL CO., LTD

www.kmcchain.com

Headquarters TEL:886-6-201 9103 E-mail:kmcweb@kmcchain.com
Europe Netherlands TEL:31-513-650 690 E-mail:info@kmcchain.nl
U.S.A California TEL:1-909-392 2045 E-mail:info@kmcchain.us

Shenzhen TEL: 86-755-2770 0111
Shanghai TEL: 86-512-5345 1661

Tianjin TEL: 86-22-6632 0988
Chengdu TEL: 86-28-8485 2227

Made in Taiwan



TAYA

TAYA Chain Co. Ltd



DHT

DIAMOND HARD TECHNOLOGY

8 Times Higher Torque Resistance



GST Tech



25 years Rust-Proof & Eco-Friendly
Quality Certification

Chrysler Ford BMW



Chains for Future Solution

HOT

e BIKE-Series **NEW**
Silver / Silver & GST



e ONZE-111

e DECA-101

e NOVE-91

e OCTO-DH



11S



10S



9S



8S



PRIMO BOX PKG **NEW**

DESIGNED PANEL PKG

COLOUR PANEL PKG



NEW Ti-Gold / Ti-Black Chains PKG



DHT(Diamond Hard Tech.)

- Elongation resistant over 7,000KM.
- 8 times longer in chain life.

Ultra Light weight design

- Reduce weight over 6%
- ISO safety standard complied.

Hollow Pin with 360° riveting

- 360° Hollow Pin Riveting.
- Ring riveting design increase strength over 250kgf.

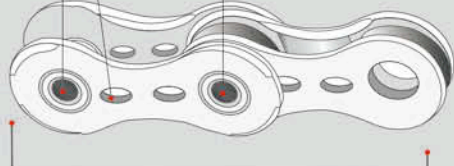

Inner Plate chamfer design

- Perform smooth shifting.
- Compatible with Shimano, SRAM and Campagnolo drivechain.

HOT 12S Series

TOLV-121



Premium Strength Series

ONZE-115(UL)

DECA-105(UL)

NOVE-95(UL)

Silver Gray

Silver Gray

Silver Gray



11S

10S

9S

SIGMA+



REUSABLE 5 times guarantee



QUICK insert and pull



EASY MAINTAIN DHT self-lubricant

HOW IT WORKS

LOCKING



Insert halves of Sigma+ Connector into both ends of chain.



Buckle both halves of sigma+ Connector together.



Pull outward.

UNLOCKING



Release Sigma+ Connector with tool.



- SCL-17 (For 12S)
- SCL-18 (For 11S)
- SCL-19 (For 10S)

Ultima Light Series

ONZE-111(UL)

DECA-101(UL)

NOVE-91(UL)

Ti-Gold Silver/Silver

Ti-Gold Silver/Silver

Ti-Gold Silver/Silver



11S

10S

9S

Durable Series

ONZE-111

DECA-101

NOVE-91

Ti-Gold Silver/Silver

Ti-Gold Silver/Silver Silver/Black

Ti-Gold Silver/Silver Silver/Black



11S

10S

9S

Economic Series

OCTO

TB-600/65

TB-50/15

408H/410H

410B

EL410

GST500 Silver/Silver Black/Black

Black/Black

GST500 Silver/Black Black/Black

GST500 Silver/Silver Black/Black

Black/Black

Black/Black



8/7S

8/7S

7/6/5S

1S

1S

1S



12 SPEED

APPLY TO SRAM EAGLE SYSTEM

- Super Durability
- SLA Superior Lubricating Aid
- DHA Chromium Carbide Pin

12_s MK12, SLA1210

For 1x drivetrain



MK12



SLA1210

TITANIUM CHAIN

World's lightest chain



- 1/2" x 11/128"
- Titanium Material
- Super Durability
- SLA Superior Lubricating Aid
- DHA Chromium Carbide Pin

11_s SLA211 Silver, Ti-N Gold

10_s SLA210 Silver, Ti-N Gold

9_s SLA209 Silver, Ti-N Gold

CHAIN LIFE



KILOMETER

Chromium Molybdenum Alloy Steel
 & Ni-PTFE Teflon Coating:
 SLA Superior Lubricating Aid

SLA SERIES

- 1/2" x 11/128" 1/2" x 3/32" 1/2" x 1/8"
- Super Light • Super Durability
- SLA Superior Lubricating Aid
- DHA Chromium Carbide Roller & Pin
- Hollow Outer & inner plate and Pin : SLA110, SLA101, SLA901, SLA410
- Hollow Outer-plate : SLA-H11, SLA-H10, SLA-H9, SLA-H8
- Hollow Pin : SLA1110

11_s SLA110, SLA-H11, SLA1110

10_s SLA101, SLA-H10

9_s SLA901, SLA-H9

8_s SLA-H8

1_s SLA410



Silver



Ti-N Gold



Ti-N Black

LIGHT SERIES CHAIN

- 1/2" x 11/128" 1/2" x 3/32" 1/2" x 1/8"
- Hollow Outer-plate : SH10, SH9, SH410
- Hollow Pin : S1010, S9010, S8010

10_s S1010(Silver), SH10(Silver, Silver/Gray)

8_s S8010 (Silver)

9_s S9010(Silver), SH9(Silver, Silver/Gray, Gray/Gray)

1_s SH410 (Silver)



ENTRY LEVEL

• 1/2" x 11/128" 1/2" x 3/32" 1/2" x 1/8"



11_s S11(Silver)

9_s S9(Silver, Silver/Gray, Gray/Gray)

7_s S52, S50

1_s S410, S410H, S410A, S512H

10_s S10(Silver, Silver/Gray)

8_s S8, S88(Silver, Silver/Gray, Gray/Gray)

6_s S20

EXERCISER CHAIN 25H





BMX SERIES

MK918, MK918H (Heavy Duty), MK926 (Light)

• Special Half Link Design

1 1/8 MK918, MK918H, MK926

1 3/8 MK918N, MK926N



MK747

1 1/8 MK747, MK747L, MK747SL

1 3/8 MK747N, MK747NSL



E-BIKE

• Special design for Mid-Motor System
 • Compatible Bike : Mid-Motor e-Bikes, BOSCH e-Bike System and other e-Bike System
 • Anti-rust is available by request

11 1/2 S11e, S11eRB

10 1/2 S10e, S10eRB

9 1/2 S9e, S9eRB

8 1/2 S8e, S8eRB

1 1/2 S512e, S512eRB, MK410



ANTI-RUST SERIES

11 1/2 **10 1/2** **9 1/2** **8 1/2**
7 1/2 **6 1/2** **1 1/2**

Anti-Rust Series for all speed bike

RUST RESISTANCE

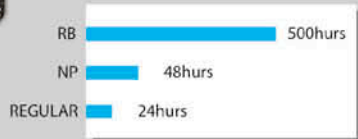

* Salt Spray Testing Results



QRs-Quick Release Safety Link (Reusable)

For your safety consideration, please use YBN QRs.

11 1/2 **10 1/2** **9 1/2** **8 1/2** **7 1/2** **6 1/2** **1 1/2**



Third restrict section and fourth restrict section will limit and lock the pin which keep the pin stay in stable to achieve high durability

Fourth restrict section will limit and lock the pin which keep the pin stay in stable to achieve high durability

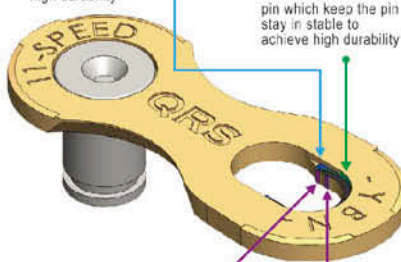

Two safe section designs will hold the pin and prevent loosening

Two safe section designs will hold the pin and prevent loosening



U.S. Invention Patent: US 8540597 B2
 TW Invention Patent: I408297
 China Invention Patent: ZL200920179712.0

Steel Pipes

Material	SCM415-SCM430
	STKM 11A
	STKM 13A
	STKM 18A
	STKM 22A
	STKM 2AD
	STKM 4AD
	All kinds of materials, such as "CR", "HR", "P/O", "GI", "G2", "1A", and so on
Purpose	bicycle pipe · motorcycle pipe · automobile pipe · furniture pipe · office supplies pipe · construction pipe, etc.



KSPYCC chain

力興鏈條有限公司
LIXING CHAIN CO., LTD.

WWW.KSPYCC.COM
E-Mail: pyctw@kspyc.com
E-Mail: pyctw2@kspyc.com

TEL:+886-6-2320859
FAX:+886-6-2025202
Tainan, Taiwan



CONNECTOR

CT820 - 9/10/11



CT830 - 6/7/8



CT850



CT840 for 1 speed



PPO Type

For all chains,
not including 10~11Speed chains



FLUORINATE

Black / Blue / Pink / Green / Dark Blue /
Orange / Red / White / Yellow / Purple



SEMI-ANODIZED

Color: Green / Red / Blue / Purple



RB ANTI-RUST

Salt Spray Test:
Test Over 500hrs Special Surface





Quality Performance & Fun

DNP Deliver
New
Possibilities

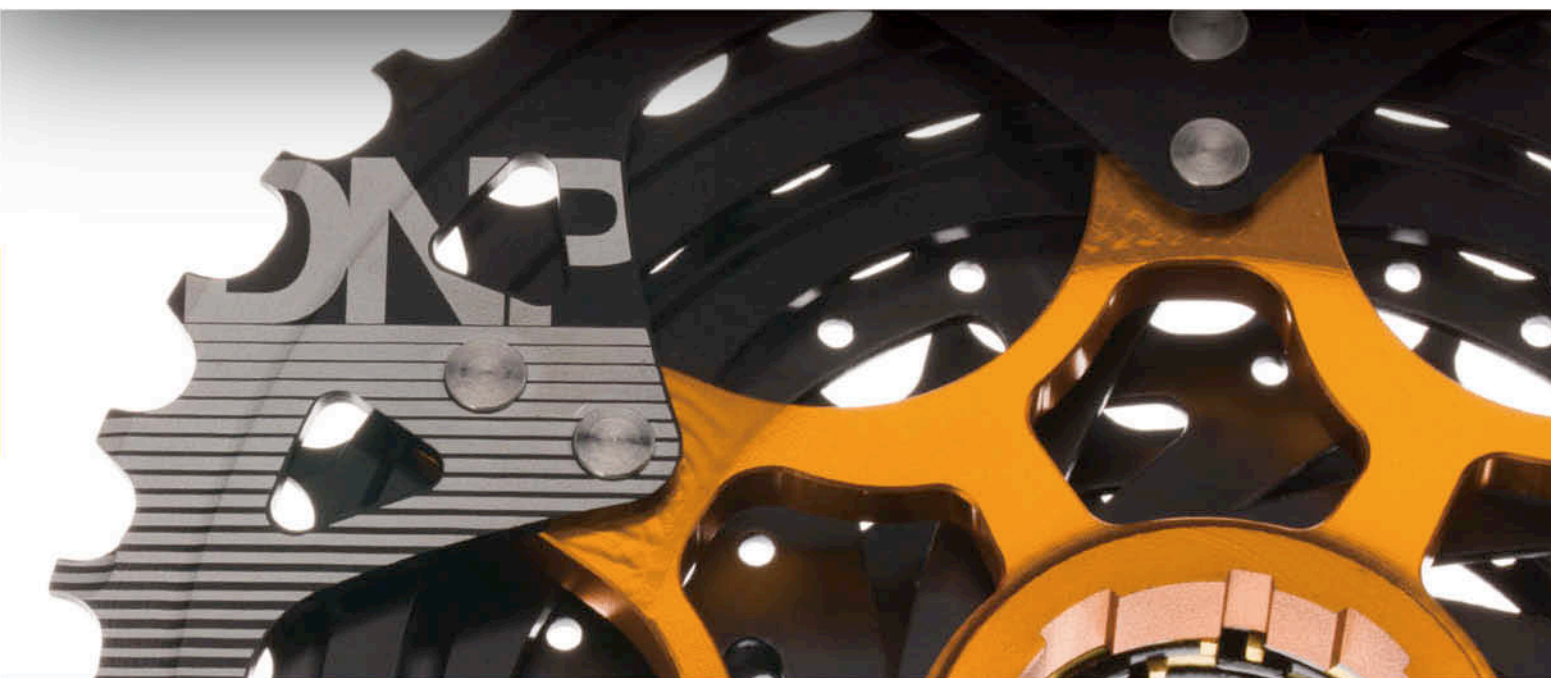

LONG YIH INDUSTRY CO.

8F-3 No.80,
Sec.2 Kuang Hu Rd., Sanchung Dist.
New Taipei City 241, Taiwan

E-Mail :info@dnp.com.tw
TEL :+886 2 2995 8777
FAX: +886 2 2995 8689
www.dnp.com.tw

RUBY



JAMES WHITE CO., LTD

Add: No 26, Alley 6, Lane 880, Sec 1 Zhongchin Road, N. Dist. Taichung City, Taiwan.

Tel: 886-4-22959740

Fax: 886-4-22960039

E-mail: jwcoltd@ms46.hinet.net

Web: jameswhite.en.taiwantrade.com



Model: COG (SCREW & CASSETTE TYPE) 12-23T W/LOCK RING.
SEPC: 1/2" X 1/8" & 1/2" X 3/32".
DIA: 1.37"
MATERIAL: STEEL.



Model: SFW: 13-22T.
SPEC: 1/2" X 1/8" / 1/2" X 3/32".
CP FINISH, 2/3/4/6/9 PAWLS.
MATERIAL: STEEL.



MULTIPLE PAWLS OF SFW.



Model: BMX SFW: 13-18T.
SPEC: 1/2" X 1/8" & 1/2" X 3/32".
DIA: 13/14/15T : 30MM...3 PAWLS.
16/17/18T: 1.37"....3/6/9 PAWLS.
MATERIAL: CR-MO-NI.



Model: SFW-16/18/20/22T/24T.
Spec: 1/2" X 1/8". 1/2" X 3/32".
Dia: 1.37"
MULTI PAWL AVAILABLE
Material: FORGED.
Finish: BK. CP. BROWN.

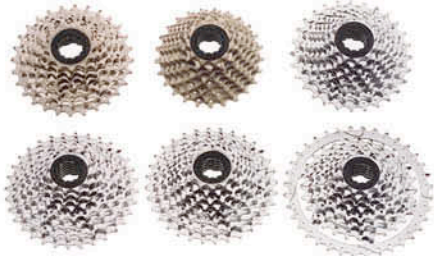

Model: 7/8 SPEED CASSETTE FREEWHEEL
MATERIAL: CR-MO STEEL
FINISH: CP/NI/BK.
7SP: 12-28T, 8SP: 11-25T, 11-28T,
11/12-32T, 11-36T.

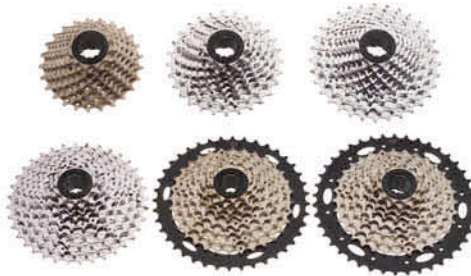

Model: 9 SPEED CASSETTE FREEWHEEL.
MATERIAL: CR-MO STEEL
FINISH: CP/NI/BK.
11-25T, 11-28T, 11-32T, 11-36T, 11-40T, 11-42T.



Model: 10 SPEED CASSETTE FREEWHEEL.
MATERIAL: CR-MO STEEL
FINISH: CP/NI/BK.
11-25T, 11-28T, 11-32T, 11-36T, 11-40T, 11-42T.



Model: 11 SPEED CASSETTE FREEWHEEL.
MATERIAL: CR-MO STEEL
FINISH: CP/NI/BK.
11-40T, 11-42T, 11-46T, 11-50T.



Model: 12 SPEED CASSETTE FREEWHEEL.
MATERIAL: CR-MO STEEL
FINISH: CP/NI/BK.
11-50T.



Model: MFW 16, 17, 18
Index Freewheel, 6, 7, 8
Speed
14-28T Lock Ring
Material: Steel
Color: Silver

FREEWHEELS/SPROCKETS 飛輪



Model LMA-8
 Size : A8H-05 1/8" x 5HOLES
 Diam : ϕ 1.37 inch
 Finish : Brown, c-p.
 Packing : Weight : 0.21kg/pc.
 Normal or greased.



Model LMA-0
 Size : AOK-14 1/2" x 1/8" x 14T
 AON-14 1/2" x 3/32" x 14T
 AON-15 1/2" x 3/32" x 15T
 Diam : ϕ 30mm
 Finish : Brown, black, c-p.
 Packing : Weight : 0.12kg/pc.
 Normal or greased.



Model LMA-1
 Size : A1K-16 1/2" x 1/8" x 16T
 Diam : ϕ 1.37 inch
 Finish : Brown, black, c-p.
 Packing : Weight : 0.14kg/pc.
 Normal or greased.



Model LMA-2
 Size : A2K-18 1/2" x 1/8" x 18T
 A3K-19 1/2" x 1/8" x 19T
 Diam : ϕ 1.37 inch
 Finish : Brown, black, c-p.
 Packing : Weight : 0.21kg/pc.
 Normal or greased.



Model LMA-3
 Size : A3K-20 1/2" x 1/8" x 20T
 Diam : ϕ 1.37 inch
 Finish : Brown, c-p.
 Packing : Weight : 0.25kg/pc.
 Normal or greased.



Model LMA-4
 Size : A4K-22 1/2" x 1/8" x 22T
 Diam : ϕ 1.37 inch
 Finish : Brown, c-p.
 Packing : Weight : 0.28kg/pc.
 Normal or greased.



Model LMA-7
 Size : A7K-12 1/2" x 1/8" 12T
 }
 A7K-19 1/2" x 1/8" x 19T
 A7N-12 1/2" x 3/32" x 12T
 }
 A7N-18 1/2" x 3/32" x 18T
 Diam : ϕ 1.37 inch
 Finish : Black, c-p



Model LMA-8
 Size : A8K-16 1/2" x 1/8" x 16T
 A8K-17 1/2" x 1/8" x 17T
 A8K-18 1/2" x 1/8" x 18T
 A8K-20 1/2" x 1/8" x 20T
 A8N-16 1/2" x 3/32" x 16T
 A8N-17 1/2" x 3/32" x 17T
 A8N-18 1/2" x 3/32" x 18T
 A8L-16 1/2" x 3/16" x 16T
 Diam : ϕ 1.37 inch
 Finish : Brown, black, c-p
 Packing : Weight : 0.14kg/pc. (16T)
 0.21kg/pc. (18T)
 Normal or greased.



Model AR
 AR004 Tool for Single freewheel of LMA-0



Model AR
 AR001 Tool for Single freewheel of LMA-8



C-P Model
 All of the above types are available
 with c-p finish.



Packing
 (1) Freewheels
 Each piece in a PE bag
 and a box, as illustrated
 above.
 50 pc. or 100 pc. in a carton.
 (2) Sprockets (Hub cogs)
 500 pc in a PE bag
 and a carton.



利達機械工業股份有限公司
LIDA MACHINERY CO., LTD.
 長億機械(昆山)有限公司
CHANG YI MACHINE (KUNSHAN) CO., LTD.

桃園市桃園區興中街2號
Tel : 886-3-3755536
 江蘇省昆山市蓬郎棧涇東路22號
Tel : 86-512-57615851

E-mail: lida@dicta.com.tw
Fax : 886-3-3777233
http://www.dicta.com.tw
Fax : 86-512-57615159

董事長 羅清諒 敬贈



SEQLite
Lightweigh Cassette

Lightweight cassette benefits

Cassette is the most direct power output
The lighter flywheel output is smaller,
Helps the rider more efficiently control
cardiorespiratory function
Cutting down the weight of the cassette is the
most effective way

SEQLite CORP. take168@seed.net.tw http://www.seqlite.com

Cr-mo Steel / 7075AL MTB Cassette

12 Speeds MTB CS + Shifter
(Use 11Sp System change CS & Shifter)

S12-1148ALS: 11-48T(315g) For Shimano 12SP

SR12-948ALS: 9-48T(375g) For SRAM 12SP

**Full 6V/4AL Titanium
Racing Cassette**

World's Lightest
Titanium Cassette

**Full Cr-Mo Steel
Racing Cassette**

4140 CR-MO

**Full 7075AL
Racing Cassette**



**USA Pat.
No.: US8663044**

Skeleton sprocket structure
reduces weight, and joined
ribs enhance rigidity.

Shimano
11 speed
cassette
is
compatible with
10 speed
hub.

Cr-mo Steel / 7075AL Racing Cassette

10/11 Speeds MTB CS
(SHIMANO Compatible) for Promotion

(Cr-mo Cog: 13 ~ 28T) (7075AL Cog: 32 ~ 4xT)

S10-1140ALS: 11-40T(255g) For Shimano 10SP

S10-1142ALS: 11-42T(265g) For Shimano 10SP

S11-1142ALS: 11-42T(280g) For Shimano 11SP

S11-1146ALS: 11-42T(300g) For Shimano 11SP

S11-1148ALS: 11-42T(310g) For Shimano 11SP



AM Box

**Solution for
Special Cassette**

Titanium part

9-14T



10-11T

10-13T

CF-E10



Coaster Brake

MODEL CF-E10:

SPOKE HOLES: 12/14G*16/20/24/28/36
 AXLE LENGTH: 165/170/175MM
 SPROCKET: 16/18/19/20T
 FINISH:CP OR BK

SMOOTH ROTATION AND COMPLETELY STOP!

MF-50



Front Derailleur

MODEL MF-50/MF-31/MF-22

LONG GAGE FOR 15-21 SPEED
 AVAILABLE 1-1/8" & 1-1/4" CLAMP
 SUITABLE FOR 48T CHAINWHEEL

MR-50



Rear Derailleur

MODEL MR-50/MR-22(A)/MR-21

INDEX REAR DERAILLEUR
 STEEL OR ALLOY, FOR 18/21/24 SPEEDS

JAK-8



MODEL JAK-8/JAK-8R

Specialized for e- tricycles and bicycles whose disc brakes are mounted on the right side

FW-1032

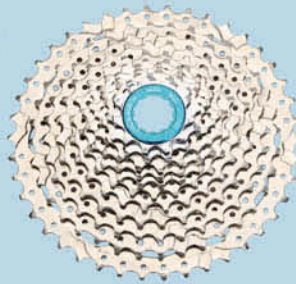

FREEWHEEL

FW-1032: 11-32T
 FW-80 : 13-28T
 FW-71 : 14-28T
 FW-61 : 14-28T
 FW-58 : 14-28T

CS-1142



CASSETTE

CS-1142: 11-42T
 7SP : 11-28T / 12-28T
 8SP : 11-23T / 11-28T / 11-32T / 12-32T
 9SP : 11-25T / 11-32T / 12-32T
 10SP : 11-27T / 11-32T / 11-36T

MLG-66/67



Grip Shifter Series

MODEL MLG-66/67

GRIP SHIFTER FOR 18/21 SPEEDS
 RIGHT INDEX, LEFT AVAILABLE FOR
 INDEX OR FIRCITION.1 SPEEDS

Y-3

MODEL Y-3/Y-3A

Standard Level
 Weight:258g
 BMC:Aluminum Die Casting Painting
 D/B:Forging Anode
 Oil:Mineral Oil
 Lever:Adjustable



L-11B



Aluminum alloy bracket and lever

S-6



Dual synchronous actuation, high stopping power with precise control

FALCONCYCLE TECH CO., LTD.

NO. 23 SEC. 2 MINZU RD., TANZI DIST., TAICHUNG, TAIWAN

E-MAIL:angel@falconcycle.com / falcon@falconcycle.com

TEL:+886-4-2535-6269 FAX:+886-4-2535-5797

**FALCON 2018
 EVTCOM 5018**

ARMLESS COASTER BRAKE

FRONT HUB (Female Axle Hub)

FRONT HUB (Female Axle Hub)

▶ CF-30

Spoke Hole: 12/16/20/24/28/32/36/48/68/140/144H
 O.L.D.: 111mm
 Axle Dim: 3/8"×150/155/168
 Shell Material: Steel
 Axle Material: #545C
 Flange PCD: 48.2/51.6mm
 Flange distance: 54mm
 Sprocket: 14/16/18/19/20/22T
 Surface: CP/ED



▶ HB-80SF

Spoke Hole : 28/32/36/48
 O.L.D : 100
 Axle Dim : M14×P1.0
 Axle Material : SCM435
 Gauge : 14G
 PCD : 39
 Shell Material : Aluminum
 Sealed Bearings : 2
 Surface : Anodized Colors per order
 ※ Female Axle Hub



▶ HB-70I

Spoke Hole : 28/32/36/48
 O.L.D : 100
 Axle Dim : M14×P1.0
 Axle Material : SCM435
 Gauge : 14G
 PCD : 39
 Shell Material : Aluminum
 Sealed Bearings : 2
 Surface : Anodized Colors per order
 ※ Female Axle Hub

BMX REAR HUB

BMX REAR HUB

BMX REAR HUB (Female Axle Hub)

FREE COASTER



▶ FH-30SR

Spoke Holes : 28H · 32H · 36H
 Axle : M14×1.0mm
 Axle Material : S45C
 Gauge : 14G
 PCD : 56mm
 Shell Material: Aluminum
 Sprocket : 9T · 10T · 11T
 Surface : Anodized Colors per order
 Options:
 w/ 4 sealed bearings : FH-30SR-4
 w/ 5 sealed bearings : FH-30SR-5



▶ FH-M3SR

Spoke Hole : 36H
 Gauge : 14G
 O.L.D.: 110mm
 Flange Distance : 51mm
 PCD : 48.8/40.4mm
 Length of Axle : 170/180mm
 Axle Dim.: M14×P1.0
 Shell Material : Aluminum
 Axle Material : CrMo
 Sprocket : 9T
 Surface : Anodized Colors per order
 Remark : RHD & LHD exchangeable



▶ FH-31SR

Spoke Hole : 28/32/36/48
 O.L.D : 110
 Axle Dim : M14×P1.0
 Axle Material : SCM435
 Gauge : 14G
 PCD : 56
 Shell Material : Aluminum
 Sprocket : 9T
 Sealed Bearings : 4/5
 Surface : Anodized Colors per order
 Options:
 w/ 4 sealed bearings : FH-31SR-4
 w/ 5 sealed bearings : FH-31SR-5
 ※ Female Axle Hub



▶ FH-50SR

Spoke Hole : 28H/36H
 O.L.D : 110
 Axle Dim : M14×P1.0/170L/175L
 Axle Material : CrMo
 Gauge : 14G
 PCD : 51.6MM
 Shell Material : Aluminum
 Sprocket : 9T
 Surface : Anodized Colors per order
 A needle bearing and an angular contact ball bearing

TRIGGER SHIFTER

GRIP SHIFTER

FRONT DERAILLEUR

REAR DERAILLEUR



▶ SL-T08 (3x8S)

SL-T07 (3x7S)
 Speed : 7, 8 INDEX
 Color : BK



▶ MLG-68

(3x8/7 Speed)
 Dual
 Index



▶ MF-52

(3x8/8 Speed)
 Top Swing
 Index
 Total Capacity 42T



▶ MR-X12(A)

(3x8 Speed)
 Index
 Gear Combination: 12-28T, 12-32T
 Total Capacity 40T

INNER 3 SPEED HUB



- ▶ I3-C (For Coaster Brake)
- ▶ I3-B (For Band Brake)
- ▶ I3-D (For Disc Brake)
- ▶ I3-V (For V-Brake)
- ▶ I3-R (For Roller Brake)

Spoke Hole : 32 / 36H
 Gauge : 13G
 Length of Axle : 177mm
 O.L.D.: 116mm
 Axle Dim.: 3/8"×24T
 Shell Material : Aluminum
 Axle Material : CrMo
 Sprocket : 16 / 18 / 20T
 Surface : Anodized Colors per order



FALCON TAIWAN

10F-2, No. 270 Chung Ming S Rd. West District,
 Taichung City, Taiwan R.O.C
 TEL: 886-4-2376-4633 FAX: 886-4-2376-0549
 E-MAIL: Kimmy@g-falconcycle.com

FALCON CHINA

No. 48 Dong Fang Road, Ludu Town Taicang, Jiangsu, China
 PC: 215412
 TEL: 86-512-5345-0678 FAX: 86-512-5345-8398
 E-MAIL: andywang@g-falconcycle.com

